

Product Manual



Contents

Air-cooled Scroll Chilled Water & Heat Pump Unit / 03-04
Low-ambient Temperature Air Source Heat Pump Unit / 05-09
Air-cooled Screw Chilled Water & Heat Pump Unit / 10-12
Natural Cooling Air-Cooled Screw Chiller / 13
Screw Water-cooled Chiller / 14-18
Screw Water (Ground) Source Heat Pump Unit / 19-24
Scroll Water-cooled Chilled (Hot) Water Unit / 25-26
Variable Frequency Falling-film Screw Chiller / 27-28
Industrial Chiller / 29-31
Centrifugal Chiller / 32- 33
Magnetic Levitation Variable Frequency Centrifugal Chiller / 34
Unitary Air-conditioning Unit / 35-40
High-static Pressure Air Duct Blowing-in Type Split AC Unit / 41-49
Rooftop Air-conditioning Unit (Split) / 50-63
Rooftop Air-conditioning Unit (Integral) / 64-77
Factory Dedicated Air-conditioning Unit / 78-81
Pharmaceutical Refrigerator Dedicated Air-conditioning / 82-84
Condensing Exhaust and Heat Recovery of Fresh Air All-in-one Machine / 85-92
Multi-connected Air-conditioning (Heat Pump) Unit / 93-103
Cabinet Type Air-handling Unit (LEG) / 104-108
Air-handling Unit (G Series) / 109-113
i-Excellence Series Modular Air-conditioning Unit / 114-115
Purification Modular Air-conditioning Unit / 116-117
Horizontal Concealed Fan Coil Unit / 118-119
Surface Mounted Fan Coil Unit / 120-122
Customer Service Hotline / 122

Air-cooled Scroll Chilled Water & Heat Pump Unit



Product Features

Most basic modular units in the industry:

There are four basic modules (refrigerating capacity: 20, 30 and 40 refrigeration ton) available in the entire series, convenient to expand.

Most complete and largest unit specifications in the industry:

There are 40 specifications of units in the entire series (refrigerating capacity: 20-400 refrigeration ton), providing wider selection and more freedom for users.

Minimum floor space of unit refrigerating capacity in the industry:

Compare with similar products, the floor space of unit refrigerating capacity reduces 33-50%, making better use of space and enjoying high cost of performance.

Most key unit technologies in the industry:

The basic modules have 8 key technologies.

A variety of customized products available:

R410A environmental-protection refrigerant is optional; units of total heat recovery, all-year refrigeration unit, low-ambient temperature heat pump and micro channel heat exchanger are optional.

Unit Model Denotation Method

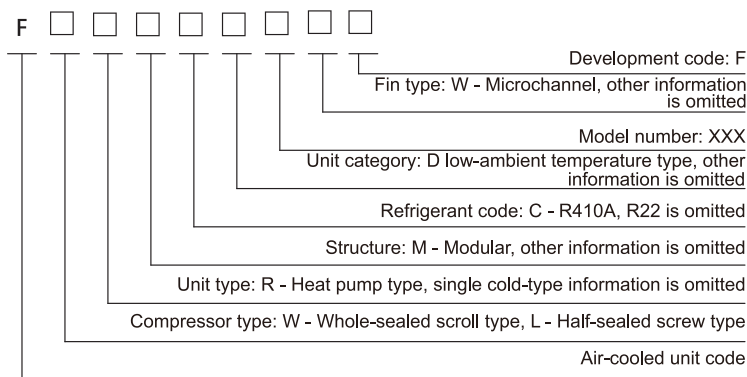

Note: The micro channel unit only has single cold-type unit and the refrigerant is R22.

Example: FWRM020F represents air-cooled scroll type water-cooled (heat pump) unit, which adopts R22 refrigerant, with the model of 020. It is the sixth generation product.

The air-cooled scroll type water-cooled (heat pump) unit produced by the company can operate stably within the operation condition range of corresponding unit with low cooling (heat) capacity attenuation.

Air-cooled Scroll Chilled Water & Heat Pump Unit

Standard Unit

Item	Type	FWRMC020F	FWRMC030F	FWRMC040F
		FWMC020F	FWMC030F	FWMC040F
Nominal refrigerating capacity	kW	65	97	130
Nominal heating capacity	kW	69	103	138
Rated refrigerating power	kW	20.2	30.1	40.3
Rated heating power	kW	19.3	28.4	38.1
Performance coefficient	kW/kW	3.21	3.22	3.22
Energy efficiency rating		2	2	2
R410A charge Qty	kg	11	16.5	22
Starting current	A	151	278	311
Max. running current	A	48	72	105
Power supply		3/N/PE AC 380/220V 50Hz		
Operation control mode		Fully automatic		
Safety protection		High/low-pressure, water cut-off delay, anti-freezing, motor overload/overheating, open-phase and phase sequence, and exhaust temperature		
Compressor type		Hermetic scroll compressor		
Fan type		High-efficient axial flow fan		
Basic module dimension L x W x H	mm	2160X1000X1920		2160X1000X1980
Water-side heat exchanger	Type	Shell and tube heat exchanger		
	Working pressure	MPa	≤1.0	
Air-side heat exchanger		Efficient red copper tube cover aluminum fin		
Water flow	m ³ /h	11.1	16.6	22.2
Water resistance	kPa	49.4	49.4	49.4
Inlet pipe size		DN50	DN50	DN50
Outlet pipe size		DN50	DN50	DN50
Unit noise	dB(A)	67	70	71
Unit weight	kg	605	800	925
Unit operating weight	kg	640	840	975

1. Nominal working condition of refrigeration: water flow of 0.172 m³/(h·kW), outlet water temperature of 7 °C, ambient temperature of 35 °C, and fouling coefficient of 0.086 m²·°C/kW.
2. Nominal working condition of heating: water flow of 0.172 m³/(h·kW), outlet water temperature of 45 °C, and ambient temperature of 7 °C (dry bulb) and 6 °C (wet bulb).
3. The above basic modules can be combined together freely, with the maximum number of modules of 16;
4. FWMC015F-FWMC040F are single-cold type unit and don't have nominal heating capacity.

Air-cooled Scroll Chilled Water & Heat Pump Unit



Product Features

Most basic modular units in the industry:

There are four basic modules (refrigerating capacity: 20, 30 and 40 refrigeration ton) available in the entire series, convenient to expand.

Most complete and largest unit specifications in the industry:

There are 40 specifications of units in the entire series (refrigerating capacity: 20-400 refrigeration ton), providing wider selection and more freedom for users.

Minimum floor space of unit refrigerating capacity in the industry:

Compare with similar products, the floor space of unit refrigerating capacity reduces 33-50%, making better use of space and enjoying high cost of performance.

Intermediate air make-up technology:

Adopt EVI enhanced vapor injection compressor to improve unit energy efficiency, expand operation scope and realize -20°C ambient temperature heating.

Super-cooling technology of air-side heat exchanger:

Super-cooling section design, to prevent the heat exchanger from freezing in winter, effectively prevent copper pipe from freezing and guarantee the heat exchange efficiency.

Low noise:

Adopt axial flow fan with large cord length and low rotation speed, with the noise level lower than the similar products in the industry.

Unit Model Denotation Method

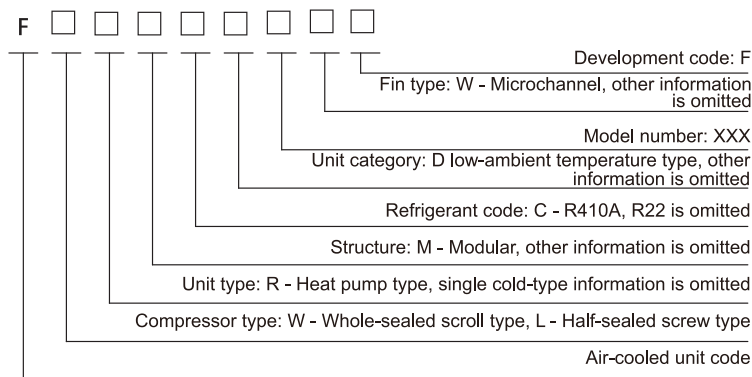

Note: The micro channel unit only has single cold-type unit and the refrigerant is R22.

Example: FWRM020F represents air-cooled scroll type water-cooled (heat pump) unit, which adopts R22 refrigerant, with the model of 020. It is the sixth generation product.

The air-cooled scroll type water-cooled (heat pump) unit produced by the company can operate stably within the operation condition range of corresponding unit with low cooling (heat) capacity attenuation.

Air-cooled Scroll Chilled Water & Heat Pump Unit

Technical Parameters of R22 Low-ambient Temperature Air Source Heat Pump Unit

Item	Type	FWRMD020G	FWRMD030G	FWRMD040G
		Nominal refrigerating capacity	kW	65
Nominal heating capacity	kW	46	68	91
Practical heating capacity	kW	69	103	138
Rated refrigerating power	kW	19.4	29	39
Rated heating power	kW	16.8	25	33.8
Practical heating power	kW	18.5	27.7	37.2
Performance coefficient	kW/kW	3.35	3.34	3.33
R22 charge Qty	kg	7.4×2	7.4×2+7.0	7.4×2+7.0×2
Starting current	A	151	278	311
Max. running current	A	48	72	105
Power supply	3/N/PE AC 380/220V 50Hz			
Operation control mode	Fully automatic			
Safety protection	High/low-pressure , water cut-off delay , anti-freezing , motor overload/overheating , open-phase and phase sequence , and exhaust temperature			
Compressor type	Hermetic scroll compressor			
Fan type	mm	High-efficient axial flow fan		
	Power	0.65×2	0.96×2	1.5×2
Basic module dimension	mm	2130×1000×1920		2130×1000×2015
L x W x H				
Waterside heat exchanger	Type	Shell and tube heat exchanger		
	Working pressure	MPa	≤1.0	
Air-side heat exchanger	Efficient red copper tube cover aluminum fin			
Water flow	m³/h	11.1	16.6	22.2
Water resistance	kPa	49.4	49.4	49.4
Inlet pipe size	DN50		DN50	DN50
Outlet pipe size	DN50		DN50	DN50
Unit noise	dB (A)	65	67	68
Unit weight	kg	630	825	950
Unit operating weight	kg	665	870	1000

1. Nominal working condition of refrigeration: water flow of 0.172 m³/(h·kW), outlet water temperature of 7 °C, ambient temperature of 35 °C, and fouling coefficient of 0.086 m²·°C/kW.

2. Nominal working condition of heating: water flow of 0.172 m³/(h·kW), outlet water temperature of 41 °C, and ambient temperature of -12 °C (dry bulb) and -14 °C (wet bulb).

3. Practical working condition of heating: water flow of 0.172 m³/(h·kW), outlet water temperature of 45 °C, and ambient temperature of 7 °C (dry bulb) and 6 °C (wet bulb).

4. The above basic modules can be combined together freely, with the maximum number of modules of 16.

Air-cooled Scroll Chilled Water & Heat Pump Unit

Technical Parameters of R22 Low-ambient Temperature Air Source Heat Pump Unit

Item		Type	FWRMDC020F	FWRMDC030F	FWRMDC040F
		Nominal refrigerating capacity	kW	65	97
Nominal heating capacity	kW	46	68	91	
Practical heating capacity	kW	69	103	138	
Rated refrigerating power	kW	20.1	30.1	40.4	
Rated heating power	kW	16.8	25	34.5	
Practical heating power	kW	18.5	27.7	37.2	
Performance coefficient	kW/kW	3.23	3.22	3.22	
R22 charge Qty	kg	6.9×2	6.9×2+6.5	6.9×2+6.5×2	
Starting current	A	165	308	331	
Max. running current	A	49	74	105	
Power supply	3/N/PE AC 380/220V 50Hz				
Operation control mode	Fully automatic				
Safety protection	High/low-pressure , water cut-off delay , anti-freezing , motor overload/overheating , open-phase and phase sequence , and exhaust temperature				
Compressor type	Hermetic scroll compressor				
Fan type	mm	High-efficient axial flow fan			
	Power	0.65×2/--	0.96×2/--	1.5×2/1.3×2	
Basic module dimension	mm	2130×1000×1920		2130×1000×2015	
L x W x H					
Water-side heat exchanger	Type	Shell and tube heat exchanger			
	Working pressure	≤1.0			
Air-side heat exchanger	Efficient red copper tube cover aluminum fin				
Water flow	m³/h	11.1	16.6	22.2	
Water resistance	kPa	49.4	49.4	49.4	
Inlet pipe size	DN50				
Outlet pipe size	DN50				
Unit noise	dB (A)	65/-	67/-	68/66	
Unit weight	kg	630	825	950	
Unit operating weight	kg	665	870	1000	

1. Nominal working condition of refrigeration: water flow of 0.172 m³/(h·kW), outlet water temperature of 7 °C, ambient temperature of 35 °C, and fouling coefficient of 0.086 m²·°C/kW.
2. Nominal working condition of heating: water flow of 0.172 m³/(h·kW), outlet water temperature of 41 °C, and ambient temperature of -12 °C (dry bulb) and -14 °C (wet bulb).
3. Practical working condition of heating: water flow of 0.172 m³/(h·kW), outlet water temperature of 45 °C, and ambient temperature of 7 °C (dry bulb) and 6 °C (wet bulb).
4. The above basic modules can be combined together freely, with the maximum number of modules of 12.

Low-ambient Temperature Air Source Heat Pump Unit

Technical Parameters of High-temperature Hot-water Type Low-ambient Temperature Air Source Heat Pump Unit - Heating Hot Water Type

Item		Type	HWDKWW69	HWDKWW138
		Nominal heating capacity	kW	46
Practical heating capacity	kW	69	138	
Rated heating power	kW	16.8	34.5	
Practical heating power	kW	22.1	45.4	
R22 charge Qty	kg	7.4×2	7.4×2+7.0×2	
Starting current	A	151	311	
Max. running current	A	48	105	
Power supply	3/N/PE AC 380/220V 50Hz			
Safety protection	High/low-pressure , water cut-off delay , anti-freezing , motor overload/overheating , open-phase and phase sequence , and exhaust temperature			
Compressor type	Hermetic scroll compressor			
Fan type	High-efficient axial flow fan			
Overall dimension: L x W x H	mm	2130×1000×1920	2130×1000×2015	
Air-side heat exchanger	Efficient red copper tube cover aluminum fin			
Water-side heat exchanger	Type	Shell and tube heat exchanger		
	Working pressure	MPa	1.0	
	Water flow	m³/h	11.1 22.2	
	Water resistance	kPa	49.4	
Scaling factor	m²·°C/kW	0.086		
Nominal heating working condition	Ambient temperature	°C	Dry bulb: -12, wet bulb: -14	
	Outlet water temperature	°C	41	
Practical heating working condition	Ambient temperature	°C	Dry bulb: 7, wet bulb: 6	
	Outlet water temperature	°C	55	
Inlet pipe size	DN50			
Outlet pipe size	DN50			
Unit noise	dB (A)	65	68	
Unit weight	kg	630	950	
Unit operating weight	kg	665	1000	

1. Nominal working condition of heating: water flow of 0.172 m³/(h·kW), outlet water temperature of 41 °C, and ambient temperature of -12 °C (dry bulb) and -14 °C (wet bulb).
2. Practical working condition of heating: water flow of 0.172 m³/(h·kW), outlet water temperature of 45 °C, and ambient temperature of 7 °C (dry bulb) and 6 °C (wet bulb).
3. The above basic modules can be combined together freely, with the maximum number of modules of 12.

Low-ambient Temperature Air Source Heat Pump Unit

Technical Parameters of High-temperature Hot-water Type Low-ambient Temperature Air Source Heat Pump Unit - Domestic Hot Water Type

Item		Type	HWDKRW69
Nominal heating capacity		kW	46
Practical heating capacity		kW	69
Rated heating power		kW	16.8
Practical heating power		kW	22.1
R22 charge Qty		kg	16
Starting current		A	151
Max. running current		A	48
Power supply	3/N/PE AC 380/220V 50Hz		
Safety protection	High/low-pressure , water cut-off delay , anti-freezing , motor overload/overheating , open-phase and phase sequence , and exhaust temperature		
Compressor type	Hermetic scroll compressor		
Fan type	High-efficient axial flow fan		
Overall dimension: - X W x H	mm	2130×1000×1920	
Air-side heat exchanger	Efficient red copper tube cover aluminum fin		
	Type	Special dual-efficient tank type heat exchanger	
Water-side heat exchanger	Working pressure	MPa	1.0
	Water flow	m ³ /h	11.1
	Water resistance	kPa	40
	Scaling factor	m ² ·°C /kW	0.086
Nominal heating working condition	Ambient temperature	°C	Dry bulb: -12, wet bulb: -14
	Outlet water temperature	°C	41
Practical heating working condition	Ambient temperature	°C	Dry bulb: 7, wet bulb: 6
	Outlet water temperature	°C	55
Inlet pipe size	DN65		
Outlet pipe size	DN65		
Unit noise	dB(A)	65	
Unit weight	kg	630	
Unit operating weight	kg	665	

- Nominal working condition of heating: water flow of 0.172 m³/(h·kW), outlet water temperature of 41 °C, and ambient temperature of -12 °C (dry bulb) and -14 °C (wet bulb).
- Practical working condition of heating: water flow of 0.172 m³/(h·kW), outlet water temperature of 45 °C, and ambient temperature of 7 °C (dry bulb) and 6 °C (wet bulb).
- The above basic modules can be combined together freely, with the maximum number of modules of 12.

Air-cooled Screw Chilled Water & Heat Pump Unit



Unit Feature

- By-pass defrosting technology**
Complete and quick defrosting as well as reliable oil supply, realizing uninterrupted heat supply;
- Enhanced vapor injection technology**
Implement quasi two-stage compression to improve the unit performance;
- Double re-cold technology**
Increase the fluid super-cooling degree and increase the refrigerating capacity;
- Split U-shape heat exchange technology**
High-efficient heat exchange, reliable oil return and convenient maintenance;
- Severe environment self-adaptation technology**
Strong environment adaptability, optimal state, efficient and reliable operation.

Unit Model Denotation Method

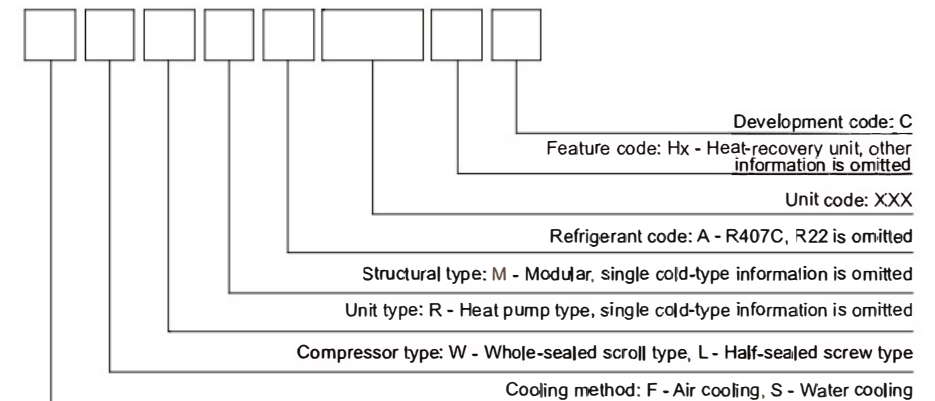

Example: FLRM680C represents air cooled screw type water-cooled (heat pump) unit, which adopts R22 refrigerant, with the model of 680. It is the fourth generation product.
The air-cooled screw type water-cooled (heat pump) unit produced by the company can operate stably within the operation condition range of corresponding unit with low cooling (heat) capacity attenuation.
The company can send engineers to provide on-site service for product installation and debugging, if required.
Please acknowledge that we may improve the product constantly, including its specification, performance, materials, and certification, etc., without further notice. Please contact our company to get the latest information.

Air-cooled Screw Chilled Water & Heat Pump Unit

Air-cooled Screw Chilled Water & Heat Pump Unit (R22)

Unit Type	FLRM		260C	360C	470C	540C	570C	630C	680C	740C	840C
	FLM										
Nominal refrigerating capacity (kW)			263	374	470	545	573	637	694	744	840
Nominal heating capacity (kW)			279	397	498	578	608	675	736	790	891
Power supply			3/N/PE AC380/220V 50Hz								
Max. running current (A)			180	269	329	333	375	180+269	204+269	269×2	269+329
Recommended wiring (mm ²)			95	185	240	240	2×95	95+185	120+185	185×2	185+240
Safety protection			High/low-pressure , water cut-off , low water-temperature , winter anti-freezing , motor overload/overheating , exhaust temperature , oil level , open-phase and phase sequence								
Compressor	Type	Semi-hermetic screw type									
	Qty (set)	1	1	1	1	1	2	2	2	2	2
	Nominal refrigeration power (kW)	76.6	107.2	138.8	160.3	171.7	183.8	200.5	214.4	246	
	Nominal heating power (kW)	72.2	100.6	131.3	151.2	161.7	172.8	188.4	201.2	231.9	
Fan	Type	Axial									
	Qty (set)	6	8	8	10	10	14	16	16	16	
	Power (kW)	6.6	8.8	8.8	11.0	11.0	15.4	17.6	17.6	17.6	
Air-side heat exchanger			Efficient red copper tube cover aluminum fin								
Water-side heat exchanger	Type	Efficient shell and tube heat exchanger									
	Water-side working pressure (MPa)	1.0									
	Water flow (m ³ /h)	45	64	81	94	99	110	119	128	144	
	Water resistance (kPa)	70	70	70	75	75	75	75	75	75	
	Pipe size (DN)	80	100	125	125	125	80+100	100×2	100×2	100+125	
Overall dimension	L (mm)	2950	3950	3950	4950	4950	7250	8250	8250	8250	
	W (mm)	2150									
	H (mm)	2620									

Unit Type	FLRM		940C	1000C	1100C	1150C	1210C	1300C	1470C	1670C	
	FLM										
Nominal refrigerating capacity (kW)			935	1010	1090	1145	1206	1301	1478	1662	
Nominal heating capacity (kW)			991	1070	1155	1214	1279	1379	1558	1754	
Power supply			3/N/PE AC380/220V 50Hz								
Max. running current (A)			329×2	329+333	333×2	375×2	269×2+329	269+329×2	329×2+333	333×2+375	
Recommended wiring (mm ²)			240×2	240×2	240×2	(2×95)×2	185×2+240	185+240×2	240×3	240×2+2×95	
Safety protection			High/low-pressure , water cut-off , low water-temperature , winter anti-freezing , motor overload/overheating , exhaust temperature , oil level , open-phase and phase sequence								
Compressor	Type	Semi-hermetic screw type									
	Qty (set)	2	2	2	2	3	3	3	3	3	
	Nominal refrigeration power (kW)	277.6	299.1	320.6	340.4	353.2	384.8	437.9	42.3		
	Nominal heating power (kW)	262.9	282.5	302.4	321.1	332.5	363.2	413.8	464.1		
Fan	Type	Axial									
	Qty (set)	16	18	20	20	24	24	26	30		
	Power (kW)	17.6	19.8	22.0	22.0	26.4	26.4	28.6	33.0		
Air-side heat exchanger			Efficient red copper tube cover aluminum fin								
Water-side heat exchanger	Type	Efficient shell and tube heat exchanger									
	Water-side working pressure (MPa)	1.0									
	Water flow (m ³ /h)	161	174	187	197	207	224	254	286		
	Water resistance (kPa)	75	80	80	80	80	80	85	85		
	Pipe size (DN)	125×2	125×2	125×2	125×2	100×2+125	100+125×2	125×3	125×3		
Overall dimension	L (mm)	8250	9250	10250	10250	12550	12550	13550	15550		
	W (mm)	2150									
	H (mm)	2620									

Note:

- Nominal working condition of refrigeration: water flow of 0.172 m³/(h·kW), outlet water temperature of 7 °C, and ambient temperature of 35 °C.
- Nominal working condition of heating: water flow of 0.172 m³/(h·kW), outlet water temperature of 45 °C, and ambient temperature of 7 °C (dry bulb) and 6 °C (wet bulb);
- Fouling coefficient of 0.086m⁻²·°C/kW;
- It is recommended that when the wiring temperature is 40 °C, PVC insulated power cable (copper wire) and splice cable shall be the iso-diameter wire produced by the same company;
- FLM260-1670C is a single-cold type unit, without heating parameters and corresponding protection function.

Air-cooled Screw Chilled Water & Heat Pump Unit

Air-cooled Screw Chilled Water & Heat Pump Unit (R407C)

Unit Type	FLRMA		250C	350C	450C	500C	550C	600C	650C	700C	800C
	FLMA										
Nominal refrigerating capacity (kW)			250	354	447	518	543	602	654	704	797
Nominal heating capacity (kW)			267	378	475	549	582	645	697	756	853
Power supply			3/N/PE AC380/220V 50Hz								
Max. running current (A)			180	269	329	333	375	180+269	204+269	269×2	269+329
Recommended wiring (mm ²)			95	185	240	240	2×95	95+185	120+185	185×2	185+240
Safety protection			High/low-pressure protection, water cut-off protection, low water-temperature protection, winter anti-freezing protection, motor overload/overheating protection, exhaust temperature protection, oil level protection, open-phase and phase sequence protection								
Compressor	Type	Semi-hermetic screw type									
	Qty (set)	1	1	1	1	1	2	2	2	2	
	Nominal refrigeration power (kW)	76.5	108.4	138.2	158.8	165.9	184.9	205.6	216.8	246.7	
	Nominal heating power (kW)	75	105	135	160	164	180	190	210	240	
Fan	Type	Axial									
	Qty (set)	6	8	8	10	10	14	16	16	16	
	Power (kW)	6.6	8.8	8.8	11.0	11.0	15.4	17.6	17.6	17.6	
Air-side heat exchanger			Efficient red copper tube cover aluminum fin								
Water-side heat exchanger	Type	Efficient shell and tube heat exchanger									
	Water-side working pressure (MPa)	1.0									
	Water flow (m ³ /h)	43	61	77	89	93	104	111	121	137	
	Water resistance (kPa)	70	70	70	75	75	75	75	75	75	
	Pipe size (DN)	80	100	125	125	125	80+100	100×2	100×2	100+125	
Overall dimension	L (mm)	2950	3950	3950	4950	4950	7250	8250	8250	8250	
	W (mm)	2150									
	H (mm)	2620									

Unit Type	FLRMA		890C	950C	1050C	1100C	1150C	1240C	1400C	1580C	
	FLMA										
Nominal refrigerating capacity (kW)			890	965	1036	1081	1146	1236	1405	1576	
Nominal heating capacity (kW)			949	1026	1098	1158	1227	1321	1496	1687	
Power supply			3/N/PE AC380/220V 50Hz								
Max. running current (A)			329×2	329+333	333×2	375×2	269×2+329	269+329×2	329×2+333	333×2+375	
Recommended wiring (mm ²)			240×2	240×2	240×2	(2×95)×2	185×2+240	185+240×2	240×3	240×2+2×95	
Safety protection			High/low-pressure , water cut-off , low water-temperature , winter anti-freezing , motor overload/overheating , exhaust temperature , oil level , open-phase and phase sequence								
Compressor	Type	Semi-hermetic screw type									
	Qty (set)	2	2	2	2	3	3	3	3	3	
	Nominal refrigeration power (kW)	276.5	297.1	317.7	331.7	355.1	384.9	435.3	483.5		
	Nominal heating power (kW)	270	295	320	328	345	375	430	484		
Fan	Type	Axial									
	Qty (set)	16	18	20	20	24	24	26	30		
	Power (kW)	17.6	19.8	22.0	22.0	26.4	26.4	28.6	33.0		
Air-side heat exchanger			Efficient red copper tube cover aluminum fin								
Water-side heat exchanger	Type	Efficient shell and tube heat exchanger									
	Water-side working pressure (MPa)	1.0									
	Water flow (m ³ /h)	153	166	178	186	197	213	242	271		
	Water resistance (kPa)	75	80	80	80	80	80	85	85		
	Pipe size (DN)	125×2	125×2	125×2	125×2	100×2+125	100+125×2	125×3	125×3		
Overall dimension	L (mm)	8250	9250	10250	10250	12550	12550	13550	15550		
	W (mm)	2150									
	H (mm)	2620									

Note:

- Nominal working condition of refrigeration: water flow of 0.172 m³/(h·kW), outlet water temperature of 7 °C, and ambient temperature of 35 °C.
- Nominal working condition of heating: water flow of 0.172 m³/(h·kW), outlet water temperature of 45 °C, and ambient temperature of 7 °C (dry bulb) and 6 °C (wet bulb);
- Fouling coefficient of 0.086m⁻²·°C/kW;
- It is recommended that when the wiring temperature is 40 °C, PVC insulated power cable (copper wire) and splice cable shall be the iso-diameter wire produced by the same company;
- FLMA250- 580C is a single-cold type unit, without heating parameters and corresponding protection function.

Natural Cooling Air-Cooled Screw Chiller

Unit Specification and Parameter Table

Unit Type			FLMB260Z	FLMB390Z	FLMB520Z	FLMB570Z
Nominal air-conditioning working condition	Nominal refrigerating capacity	kW	264	395	520	570
	total input power	kW	82	121.5	155.5	172
IDC air-conditioning working condition	Nominal refrigerating capacity	kW	287.3	431.4	569	667.3
	total input power	kW	87.4	129.4	165.7	183.3
Natural cooling working condition	Nominal refrigerating capacity	kW	287	431	569	697
	total input power	kW	11.4	17.1	22.9	28.6
Ambient temperature (100% natural cooling)		°C	0	0	0	0.8
Power supply			3/N/PE AC380/220V~50Hz			
Max. running current		A	224	320	409	463
Recommended wiring		mm ²	150	240	120 x 2	150 x 2
Refrigerant	Type		R134a			
	Qty	kg	55	73	90	105
Throttling device			Electronic expansion valve			
Compressor	Type		Semi-hermetic screw type			
	Qty	set	1	1	1	1
	Energy adjustment mode		Stepless adjustment			
	Energy adjustment scope	%	25% , 50~100%			
Fan	Type		Axial low-noise fan (variable-frequency + fixed frequency)			
	Qty	set	4	6	8	10
	Power	kW	2.85 x 4	2.85 x 6	2.85 x 8	2.85 x 10
Air-side heat exchanger			Efficient inner-thread red copper tube cover aluminum fin			
Water-side heat exchanger	Type		Efficient shell and tube heat exchanger			
	Water-side max. pressure	MPa	1			
	Pipe size	DN	125	125	125	125
Water flow		m ³ /h	46.3	69.3	91.2	100
Water resistance (compressor working condition)		kPa	47.8	65.3	57.8	66.1
Water resistance (natural cooling working condition)		kPa	149.9	153.7	154.9	122.2
Overall dimension	L	mm	2372	3555	4738	5921
	W	mm	2268			
	H	mm	2590			
Unit quality		kg	3940	5270	6280	7320
Unit operation quality		kg	4080	5510	6640	7680
Safety protection			High/low-pressure , water cut-off , low water-temperature , winter anti-freezing , motor overload/overheating , exhaust temperature , oil level , open-phase and phase sequence			
Noise		dB(A)	73	74	74	76

Note:
 1. Working condition of nominal air-conditioning: Ambient temperature of 35°C, outlet water temperature of 7 °C, and refrigerant is ethylene glycol solution with the concentration of 20%;
 2. Working condition of IDC air-conditioning: Ambient temperature of 35°C, outlet water temperature of 18 °C, and refrigerant is ethylene glycol solution with the concentration of 20%;
 3. Working condition of natural cooling: Ambient temperature of 0°C, outlet water temperature of 18 °C, and refrigerant is ethylene glycol solution with the concentration of 20%;
 4. Ambient temperature (100% natural cooling): Under the ambient temperature, the inlet water temperature is 18 °C, and the natural cooling is able to provide 100% "refrigeration quantity of IDC air-conditioning working condition";
 5. It is recommended that when the wiring temperature is 40 °C, PVC insulated power cable (copper wire) and splice cable shall be the iso-diameter wire produced by the same company;
 6. The modular unit can be combined with different modules (1-4 modules) as needed. The above table is the parameters of a single unit.

Screw Water-cooled Chiller

Screw Water-cooled Chiller



Unit Feature

- 1. Basic chiller**
The refrigerating capacity of series units ranges from 176kW to 3600kW. Through years of market validation, it is proved to have reliable quality and stable operation.
- 2. Heat recovery chiller**
The unit adopts heat recovery condenser to produce domestic hot water of 45-55°C by using the exhaust waste heat of compressor.
- 3. Dual-compressor parallel design**
The full-liquid unit adopts unique dual-compressor parallel design, with partial load operation efficiency at international leading standard.
- 4. Highly intelligent control system**
Adopt industrial controller, equipped with Chinese display and user-friendly interface, convenient to operate.
- 5. Reliable product quality**
Each unit is tested in strict accordance with the provisions of national standards by using the full-performance test bench designed and produced by Hefei General Machinery Research Institute. It is permitted to leave the factory only when all performance indexes reach or exceed the national standard requirements.

Unit Model Denotation Method

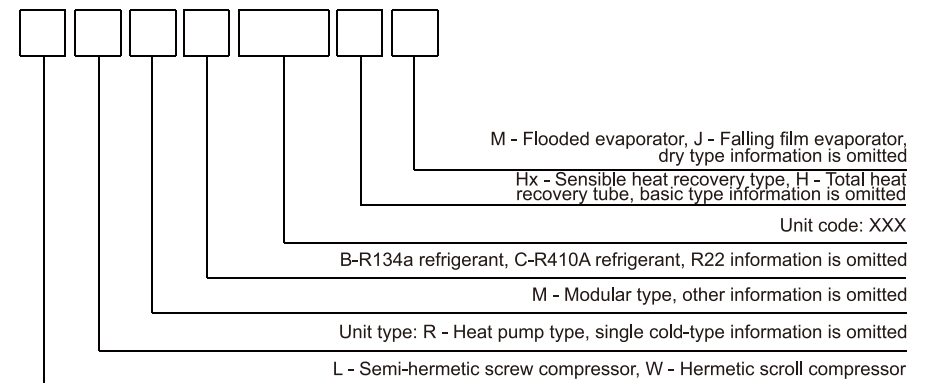

Example: SL920HM indicates total heat-recovery type screw water-cooled chiller using flooded evaporator, with the model code of 920.

Screw Water-cooled Chiller

Unit Technical Parameter

Screw Water-cooled Chiller (R22)

Basic type		SL180	SL220	SL260	SL310	SL350	SL400	SL450	SL500	SL550	SL600	SL670	SL740	SL800	
Sensible heat recovery type		SL180Hx	SL220Hx	SL260Hx	SL310Hx	SL350Hx	SL400Hx	SL450Hx	SL500Hx	SL550Hx	SL600Hx	SL670Hx	SL740Hx	SL800Hx	
Total heat recovery type		SL180H	SL220H	SL260H	SL310H	SL350H	SL400H	SL450H	SL500H	SL550H	SL600H	SL670H	SL740H	SL800H	
Nominal working condition of refrigeration	Nominal refrigerating capacity	kW	176	215	260	311	352	403	448	504	545	604	665	744	799
		10 ⁴ kcal/h	15	18	22	27	30	35	39	43	47	52	57	64	69
	Rated power	kW	37.8	46.2	55.7	66.8	75.3	85.9	95.4	107.1	114.5	126.0	137.6	153.3	163.8
	COP	kW/kW	4.65	4.65	4.66	4.65	4.67	4.69	4.69	4.70	4.75	4.79	4.83	4.85	4.87
Power supply		--	3/N/PE AC380/220V 50Hz												
Electric supply		--	High/low-pressure , safety valve , water cut-off delay , anti-freezing , motor overload , open-phase and phase sequence												
Compressor	Type	--	Semi-hermetic screw type/25%-100% stepless adjustment												
	Qty	set	1												
Evaporator	Type	--	U-type dry shell and tube (designed bearing water pressure of 1.0MPa)												
	Water flow	m ³ /h	30	37	45	53	61	69	77	87	94	104	114	128	137
	Water resistance	kPa	60	60	60	65	65	65	60	60	60	60	65	65	65
Condenser	Type	--	Horizontal shell and tube type (designed bearing water pressure of 1.0MPa)												
	Water flow	m ³ /h	38	46	56	67	76	87	96	108	117	130	143	160	172
	Water resistance	kPa	40	40	40	40	40	40	45	45	45	50	50	60	60
Sensible heat recovery type (optional)	Heat recovery Qty	kW	44	54	65	78	88	101	112	126	136	151	166	186	200
	Heat recovery water flow	m ³ /h	8	9	11	13	15	17	19	22	23	26	29	32	34
Total heat recovery type (optional)	Heat recovery water flow	m ³ /h	20	20	20	20	20	20	20	20	25	25	25	25	25
	Heat recovery water resistance	kPa	40	40	40	40	40	40	45	45	45	50	50	60	60
Refrigerant R22 charge Qty	Basic type	kg	33	41	49	59	66	76	85	95	103	114	125	140	151
	Sensible heat recovery type	kg	41	50	58	69	76	86	95	105	113	124	135	150	161
	Total heat recovery type	kg	45	55	63	74	80	90	100	110	118	129	140	155	166

Note:

- Nominal working condition of refrigeration: Outlet water temperature of chilled water is 7 °C and calculate the water flow according to "nominal refrigerating capacity" x 0.172m³(h • kW); inlet water temperature of cooling water is 30 °C and calculate the water flow according to "nominal refrigerating capacity" x 0.215m³(h • kW);
- Working condition of heat recovery: Inlet-outlet water temperature of heat recovery is 45/50 °C; outlet water temperature of chilled water is 7 °C; water flow is same with the chilled water flow under nominal working condition of refrigeration; the unit supplies hot water at the same time of refrigeration operation, but it cannot supply hot water only;
- The outlet water temperature of chilled water is 5-15 °C and that of heat recovery is 35-55 °C; the fouling coefficient of evaporator water side is 0.018m² •°C/kW and that of condenser water side is 0.44m²•°C/kW;
- For more detailed information including unit dimension, weight, and wiring etc., please refer to more specific large sample.

Screw Water-cooled Chiller

Screw Water-cooled Chiller (R22)

Basic type		SL870M	SL920M	SL980M	SL1050M	SL1150M	SL1230M	SL1330M	SL1420M	SL1530M	SL1600M	
Total heat recovery type		SL870HM	SL920HM	SL980HM	SL1050HM	SL1150HM	SL1230HM	SL1330HM	SL1420HM	SL1530HM	SL1600HM	
Nominal working condition of refrigeration	Nominal refrigerating capacity	kW	865	924	975	1050	1152	1232	1332	1418	1532	1602
		10 ⁴ kcal/h	74	79	84	90	99	106	115	122	132	138
	Rated power	kW	154.0	164.0	173.0	186.0	203.0	218.0	237.0	251.0	272.0	284.0
	COP	kW/kW	5.61	5.63	5.63	5.64	5.67	5.65	5.62	5.64	5.63	5.64
Power supply		--	3/N/PE AC380/220V 50Hz									
Safety protection		--	High/low-pressure , oil level , safety valve , water cut-off delay , anti-freezing , motor overload , open-phase and phase sequence									
Compressor	Type	--	Semi-hermetic screw type/25%-100% stepless adjustment									
	Qty	set	2									
Evaporator	Type	--	Flooded type (designed bearing water pressure of 1.0MPa)									
	Water flow	m ³ /h	149	159	168	181	198	212	229	244	264	276
	Water resistance	kPa	60	60	60	60	62	62	62	65	65	65
Condenser	Type	--	Horizontal shell and tube type (designed bearing water pressure of 1.0MPa)									
	Water flow	m ³ /h	186	199	210	226	248	265	286	305	329	344
	Water resistance	kPa	66	66	66	66	70	70	70	72	72	
Total heat recovery type (optional)	Heat recovery refrigerating capacity	kW	746	790	838	885	974	1027	1132	1218	1310	1383
	Heat recovery Qty	kW	959	1017	1078	1141	1251	1315	1449	1566	1685	1778
	Heat recovery power	kW	213	227	240	256	277	288	317	348	375	395
	Heat recovery water flow	m ³ /h	165	175	185	196	215	226	249	269	290	306
Refrigerant R22 charge Qty	Basic type	kg	280	340	340	350	370	380	390	400	410	420
	Total heat recovery type	kg	305	360	370	380	410	420	430	440	460	470

Basic type		SL1720M	SL1850M	SL1970M	SL2100M	SL2200M	SL2300M	SL2750M	SL3200M	SL3600M	
Total heat recovery type		SL1720HM	SL1850HM	SL1970HM	SL2100HM	SL2200HM	SL2300HM	--	--	--	
Nominal working condition of refrigeration	Nominal refrigerating capacity	kW	1715	1845	1974	2100	2202	2304	2750	3204	3600
		10 ⁴ kcal/h	147	159	170	181	189	198	236	275	310
	Rated power	kW	303.0	325.0	346.0	366.0	382.0	402.0	488.0	568.0	636.0
	COP	kW/kW	5.66	5.67	5.70	5.73	5.76	5.73	5.63	5.64	5.66
Power supply		--	3/N/PE AC380/220V 50Hz								
Safety protection		--	High/low-pressure , oil level , safety valve , water cut-off delay , anti-freezing , motor overload , open-phase and phase sequence								
Compressor	Type	--	Semi-hermetic screw type/25%-100% stepless adjustment								
	Qty	set	4								
Evaporator	Type	--	Flooded type (designed bearing water pressure of 1.0MPa)								
	Water flow	m ³ /h	295	317	340	361	379	396	473	551	619
	Water resistance	kPa	70	70	65	65	65	67	67	70	75
Condenser	Type	--	Horizontal shell and tube type (designed bearing water pressure of 1.0MPa)								
	Water flow	m ³ /h	369	397	424	452	473	495	591	689	774
	Water resistance	kPa	75	75	71	71	71	74	74	75	80
Total heat recovery type (optional)	Heat recovery refrigerating capacity	kW	1455	1533	1580	1775	1894	1981	--	--	--
	Heat recovery Qty	kW	1872	1972	2053	2278	2422	2533	--	--	--
	Heat recovery power	kW	417	439	473	503	528	552	--	--	--
	Heat recovery water flow	m ³ /h	322	339	353	392	417	436	--	--	--
	Heat recovery water resistance	kPa	72	72	72	72	72	72	--	--	--
Refrigerant R22 charge Qty	Basic type	kg	480	500	510	510	550	550	790	840	1000
	Total heat recovery type	kg	520	530	540	550	560	570	--	--	--

Note:

- Nominal working condition of refrigeration: Outlet water temperature of chilled water is 7 °C and calculate the water flow according to "nominal refrigerating capacity" x 0.172m³(h•kW); inlet water temperature of cooling water is 30 °C and calculate the water flow according to "nominal refrigerating capacity" x 0.215m³(h•kW);
- Working condition of heat recovery: Inlet-outlet water temperature of heat recovery is 45/50 °C outlet water temperature of chilled water is 7 °C; water flow is same with the chilled water flow under nominal working condition of refrigeration; the unit supplies hot water at the same time of refrigeration operation, but it cannot supply hot water only;
- The outlet water temperature of chilled water is 5-15 °C and that of heat recovery is 35-55 °C; the fouling coefficient of evaporator water side is 0.018m² •°C/kW and that of condenser water side is 0.44m² •°C/kW;
- For more detailed information including unit dimension, weight, and wiring etc., please refer to more specific large sample.

Screw Water-cooled Chiller

Unit Technical Parameter

Technical Parameters for Screw Water-cooled Chiller (R134a)

Basic type		SLB180	SLB220	SLB260	SLB310	SLB350	SLB400	SLB450	SLB500	SLB550	SLB600	SLB670	SLB740	SLB800	
Total heat recovery type		SLB180H	SLB220H	SLB260H	SLB310H	SLB350H	SLB400H	SLB450H	SLB500H	SLB550H	SLB600H	SLB670H	SLB740H	SLB800H	
Nominal working condition of refrigeration	Nominal refrigerating capacity	kW	185	223	265	305	344	393	452	504	554	607	672	740	808
	Rated power	10 ³ kcal/h	15.9	19.2	22.8	26.2	29.6	33.8	38.9	43.3	47.6	52.2	57.8	63.6	69.5
	Rated power	kW	39	47	55	64	72	82	94	104	114	123	135	149	162
COP		kW/kW	4.74	4.74	4.81	4.76	4.77	4.79	4.80	4.84	4.85	4.93	4.97	4.96	4.98
	Power supply		3/N/PE AC380/220V 50Hz												
Safety protection			Semi-hermetic screw type/25%-100% stepless adjustment												
Compressor	Type		High/low-pressure , safety valve, water cut-off delay , anti-freezing , motor overload , open-phase and phase sequence												
	Qty	set	1												
Evaporator	Type		U-type dry shell and tube (designed bearing water pressure of 1.0MPa)												
	Water flow	m ³ /h	32	38	46	52	59	68	78	87	95	104	116	127	139
Water resistance		kPa	50	50	60	60	60	60	65	65	65	65	65	65	65
	Type		Horizontal shell and tube type (designed bearing water pressure of 1.0MPa)												
Condenser	Water flow	m ³ /h	40	48	57	66	74	84	97	108	119	131	144	159	174
	Water resistance	kPa	40	40	40	40	40	40	45	45	45	50	50	60	60
Sensible heat recovery type (optional)	Heat recovery Qty	kW	46	56	66	76	86	98	113	126	139	152	168	185	202
	Hot water flow	m ³ /h	8	10	11	13	15	17	19	22	24	26	29	32	35
	Hot water resistance	kPa	20	20	20	20	20	20	20	20	20	20	25	25	25
Total heat recovery type (optional)	Heat recovery refrigerating capacity	kW	143	172	205	249	281	321	369	411	452	495	548	604	659
	Heat recovery Qty	kW	195	229	274	328	369	421	487	544	592	644	713	788	869
	Heat recovery power	kW	52	57	69	79	88	100	118	133	140	149	165	184	210
R134a charge Qty	Heat recovery water flow	m ³ /h	34	39	47	56	63	72	84	94	102	111	123	136	149
	Heat recovery water resistance	kPa	40	40	40	40	40	40	45	45	45	50	50	60	60
Basic type		kg	40	46	55	64	77	84	94	102	110	120	128	142	160
	Sensible heat recovery type	kg	41	50	58	67	75	86	95	107	115	126	138	153	164
Total heat recovery type		kg	45	55	63	74	80	90	100	110	118	129	140	155	166

Note:

- Nominal working condition of refrigeration: Outlet water temperature of chilled water is 7 °C and calculate the water flow according to "nominal refrigerating capacity" x 0.172m³/(h•kW); inlet water temperature of cooling water is 30 °C and calculate the water flow according to "nominal refrigerating capacity" x 0.215m³/(h•kW);
- Working condition of heat recovery: Inlet-outlet water temperature of heat recovery is 45/50 °C outlet water temperature of chilled water is 7 °C; water flow is same with the chilled water flow under nominal working condition of refrigeration; the unit supplies hot water at the same time of refrigeration operation, but it cannot supply hot water only;
- The outlet water temperature of chilled water is 5-15 °C and that of heat recovery is 35-60 °C; the fouling coefficient of evaporator water side is 0.018m²•°C/kW and that of condenser water side is 0.44m²•°C/kW;
- For more detailed information including unit dimension, weight, and wiring etc., please refer to more specific large sample.

Screw Water-cooled Chiller

Technical Parameters for Screw Water-cooled Chiller (R134a)

Basic type		SLB400J	SLB450J	SLB500J	SLB550J	SLB600J	SLB670J	SLB740J	SLB800J	SLB870J	SLB920J	SLB980J	SLB1050J	
Total heat recovery type		SLB400HJ	SLB450HJ	SLB500HJ	SLB550HJ	SLB600HJ	SLB670HJ	SLB740HJ	SLB800HJ	SLB870HJ	SLB920HJ	SLB980HJ	SLB1050HJ	
Nominal working condition of refrigeration	Nominal refrigerating capacity	10 ³ kcal/h	34.5	39.0	43.0	47.7	51.8	58.4	63.2	69.6	75	80	85	91
	Rated power	kW	71	80	87	97	104	116	128	141	153	161	171	183
	COP	kW/kW	5.65	5.68	5.75	5.72	5.79	5.85	5.74	5.74	5.71	5.75	5.76	5.77
Power supply			3/N/PE AC380/220V 50Hz											
Safety protection			High/low-pressure , oil level, safety valve, water cut-off delay , anti-freezing , motor overload , open-phase and phase sequence											
Compressor	Type		Semi-hermetic screw type/25%-100% stepless adjustment											
	Qty	set	1											
Evaporator	Type		Falling film type (designed bearing water pressure of 1.0MPa)											
	Water flow	m ³ /h	69	78	86	95	104	117	126	139	150	159	169	181
Water resistance		kPa	56	56	58	58	59	59	60	60	60	60	60	60
	Type		Horizontal shell and tube type (designed bearing water pressure of 1.0MPa)											
Condenser	Water flow	m ³ /h	86	98	108	119	129	146	158	174	188	199	212	227
	Water resistance	kPa	62	62	63	64	64	65	65	66	66	66	66	66
Total heat recovery type (optional)	Heat recovery refrigerating capacity	kW	321	363	400	444	482	543	588	647	699	741	788	844
	Heat recovery Qty	kW	418	472	518	576	623	701	762	839	909	965	1030	1101
	Heat recovery power	kW	97	109	118	132	141	158	174	192	210	224	242	257
Refrigerant R134a charge Qty	Heat recovery water flow	m ³ /h	72	81	89	99	107	121	131	144	156	166	177	189
	Heat recovery water resistance	kPa	56	56	57	58	58	59	59	60	60	60	60	60
	Basic type	kg	140	148	152	158	170	175	180	185	240	250	255	260
Total heat recovery type	kg	154	163	167	174	187	193	198	204	270	280	290	290	

Basic type		SLB1150J	SLB1230J	SLB1330J	SLB1420J	SLB1530J	SLB1600J	SLB1720J	SLB1850J	SLB2050J	SLB2200J	SLB2350J	SLB2500J	
Total heat recovery type		SLB1150HJ	SLB1230HJ	SLB1330HJ	SLB1420HJ	SLB1530HJ	SLB1600HJ	SLB1720HJ	SLB1850HJ	SLB2050HJ	SLB2200HJ	SLB2350HJ	SLB2500HJ	
Nominal working condition of refrigeration	Nominal refrigerating capacity	10 ³ kcal/h	1154	1233	1332	1422	1531	1605	1724	1853	2040	2202	2350	2490
	Rated power	kW	99	106	115	122	132	138	148	159	175	189	202	214
	COP	kW/kW	5.77	5.82	5.84	5.85	5.82	5.82	5.82	5.83	5.85	5.87	5.88	5.90
Power supply			3/N/PE AC380/220V 50Hz											
Safety protection			High/low-pressure , oil level, safety valve, water cut-off delay , anti-freezing , motor overload , open-phase and phase sequence											
Compressor	Type		Semi-hermetic screw type/12.5%-100% stepless adjustment											
	Qty	set	2											
Evaporator	Type		Falling film type (designed bearing water pressure of 1.0MPa)											
	Water flow	m ³ /h	198	212	229	245	263	276	297	319	351	379	404	428
Water resistance		kPa	62	62	62	65	65	65	70	70	71	71	72	72
	Type		U-type dry shell and tube (designed bearing water pressure of 1.0MPa)											
Condenser	Water flow	m ³ /h	248	265	286	306	329	345	371	398	439	473	505	535
	Water resistance	kPa	70	70	70	70	72	72	75	75	76	76	77	77
Total heat recovery type (optional)	Heat recovery refrigerating capacity	kW	924	987	1066	1136	1219	1285	1380	1483	1632	1761	1880	1992
	Heat recovery Qty	kW	1195	1274	1372	1458	1556	1662	1783	1911	2105	2271	2428	2566
	Heat recovery power	kW	271	287	306	322	337	377	403	428	473	510	546	574
Refrigerant R134a charge Qty	Heat recovery water flow	m ³ /h	206	219	236	251	268	286	307	329	362	391	417	441
	Heat recovery water resistance	kPa	66	66	66	66	70	70	72	72	73	73	73	73
	Basic type	kg	270	280	290	300	310	315	320	335	420	430	450	460
Total heat recovery type	kg	300	310	330	340	350	360	360	380	460	475	490	500	

Note:

- Nominal working condition of refrigeration: Outlet water temperature of chilled water is 7 °C and calculate the water flow according to "nominal refrigerating capacity" x 0.172m³/(h•kW); inlet water temperature of cooling water is 30 °C and calculate the water flow according to "nominal refrigerating capacity" x 0.215m³/(h•kW);
- Working condition of heat recovery: Inlet-outlet water temperature of heat recovery is 45/50 °C; outlet water temperature of chilled water is 7 °C; water flow is same with the chilled water flow under nominal working condition of refrigeration; the unit supplies hot water at the same time of refrigeration operation, but it cannot supply hot water only;
- The outlet water temperature of chilled water is 5-15 °C and that of heat recovery is 35-60 °C; the fouling coefficient of evaporator water side is 0.018 m²•°C/kW and that of condenser water side is 0.44m²•°C/kW;
- For more detailed information including unit dimension, weight, and wiring etc., please refer to more specific large sample.

Screw Water (Ground) Source Heat Pump Unit

Screw Water (Ground) Source Heat Pump Unit



Unit Feature

1. Basic type water (ground) source heat pump unit

The refrigerating capacity of series units ranges from 185kW to 3700kW and the heating capacity is 201kW-4074kW. It is proved to have reliable quality and stable operation.

2. Heat recovery chiller

The unit adopts heat recovery condenser to produce domestic hot water of 45-55°C by using the exhaust waste heat of compressor.

3. Dual-compressor parallel design

The full-liquid unit adopts unique dual-compressor parallel design, with partial load operation efficiency at international leading standard.

4. Highly intelligent control system

Adopt industrial controller, equipped with Chinese display and user-friendly interface, convenient to operate.

5. Reliable product quality

Each unit is tested in strict accordance with the provisions of national standards by using the full-performance test bench designed and produced by Hefei General Machinery Research Institute. It is permitted to leave the factory only when all performance indexes reach or exceed the national standard requirements.

Unit Model Denotation Method

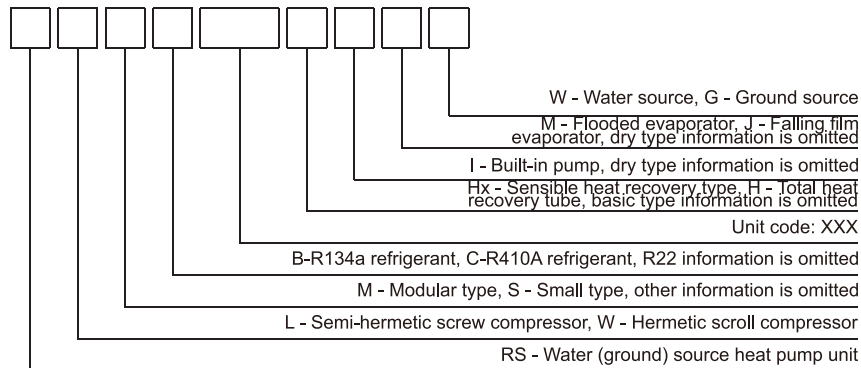

Example: RSLB910JW indicates falling film type screw water source heat pump unit using R134a refrigerant, with the model code of 910.

Note: The unit model in the following parameters doesn't indicate water source (W) or ground source (G), please specify water source (W) or ground source (G) at the time of ordering.

Screw Water (Ground) Source Heat Pump Unit

Unit Technical Parameter

Screw Water (Ground) Source Heat Pump Unit (R22)

Basic type		RSL180	RSL220	RSL270	RSL320	RSL370	RSL420	RSL470	RSL520	RSL570	RSL630	RSL690	RSL770	RSL830	
Sensible heat recovery type		RSL180Hx	RSL220Hx	RSL270Hx	RSL320Hx	RSL370Hx	RSL420Hx	RSL470Hx	RSL520Hx	RSL570Hx	RSL630Hx	RSL690Hx	RSL770Hx	RSL830Hx	
Total heat recovery type		RSL180H	RSL220H	RSL270H	RSL320H	RSL370H	RSL420H	RSL470H	RSL520H	RSL570H	RSL630H	RSL690H	RSL770H	RSL830H	
Nominal working condition of refrigeration	Nominal refrigerating capacity	kW	185(179)	224(217)	270(262)	323(313)	366(355)	419(406)	466(452)	524(508)	567(550)	628(609)	692(671)	774(751)	831(806)
	Rated power	kW	33(34)	40(42)	49(51)	58(60)	66(69)	75(78)	83(86)	93(97)	100(104)	111(115)	122(127)	137(142)	147(153)
Nominal working condition of heating	Nominal heating capacity	kW	201(193)	246(236)	297(285)	355(341)	403(387)	461(443)	513(492)	576(553)	624(599)	691(663)	761(731)	851(817)	914(877)
	Rated power	kW	45(45)	54(53)	64(63)	76(75)	86(85)	98(97)	109(108)	122(121)	131(130)	144(143)	160(158)	180(178)	190(188)
Annual comprehensive performance coefficient (ACOP)		kW/kW	5.1(4.83)	5.14(4.85)	5.12(4.86)	5.17(4.92)	5.16(4.88)	5.19(4.92)	5.21(4.94)	5.23(4.94)	5.27(4.98)	5.27(5)	5.26(4.99)	5.24(4.98)	5.28(5)
Power supply		—	3/N/PE AC380/220V 50Hz												
Safety protection		—	High/low-pressure , safety valve , water cut-off delay , anti-freezing , motor overload , open-phase and phase sequence												
Compressor	Type	—	Semi-hermetic screw type/25%-100% stepless adjustment												
	Qty	set	1												
Evaporator	Type	—	U-type dry shell and tube (designed bearing water pressure of 1.0MPa)												
	Refrigerating water flow	m ³ /h	32(31)	39(37)	46(45)	56(54)	63(61)	72(70)	80(78)	90(87)	98(95)	108(105)	119(115)	133(129)	143(139)
	Refrigerating water resistance	kPa	66(63)	66(63)	66(63)	72(68)	72(68)	72(68)	66(63)	66(63)	66(63)	66(63)	71(68)	72(68)	72(68)
	Heating water flow	m ³ /h	19(38)	23(47)	28(56)	33(67)	38(76)	43(87)	48(97)	54(109)	58(118)	65(131)	71(144)	80(161)	86(173)
Condenser	Heating water resistance	kPa	30(78)	30(78)	30(78)	33(85)	33(85)	33(85)	30(78)	30(78)	30(78)	30(78)	33(85)	33(85)	33(85)
	Type	—	Horizontal shell and tube type (designed bearing water pressure of 1.0MPa)												
	Refrigerating water flow	m ³ /h	19(38)	23(47)	28(56)	33(67)	38(76)	43(87)	48(97)	54(109)	58(118)	65(131)	71(144)	80(161)	86(173)
	Refrigerating water resistance	kPa	21(42)	21(42)	21(42)	21(42)	21(42)	21(42)	24(47)	24(47)	27(53)	27(53)	27(53)	32(63)	32(63)
Sensible heat recovery type (optional)	Heat recovery water flow	m ³ /h	32(31)	39(37)	46(45)	56(54)	63(61)	72(70)	80(78)	90(87)	98(95)	108(105)	119(115)	133(129)	143(139)
	Heat recovery water resistance	kPa	36(34)	36(34)	36(34)	36(34)	36(34)	36(34)	41(38)	41(38)	41(38)	45(43)	45(43)	54(51)	54(51)
	Heat recovery Qty	kg	44	54	65	78	88	101	112	126	136	151	166	186	200
	Heat recovery power	kW	152	186	224	268	304	348	387	435	471	521	574	642	690
Total heat recovery type (optional)	Heat recovery power	kW	201	245	295	352	399	457	507	569	615	679	747	835	894
	Heat recovery Qty	kg	49	59	71	84	95	109	120	134	144	158	173	193	204
	Heat recovery water flow	m ³ /h	35	42	51	61	69	79	87	98	106	117	128	144	154
	Heat recovery water resistance	kPa	40	40	40	40	40	40	45	45	45	50	50	60	60
Refrigerant R22 charge Qty	Basic type	kg	33	41	49	59	66	76	85	95	103	114	125	140	151
	Sensible heat recovery type	kg	41	50	58	69	76	86	95	105	113	124	135	150	161
	Total heat recovery type	kg	45	55	63	74	80	90	100	110	118	129	140	155	166

Basic type		RSL910M	RSL960M	RSL1010M	RSL1090M	RSL1190M	RSL1280M	RSL1380M	RSL1480M	RSL1590M	RSL1660M	
Total heat recovery type		RSL910HM	RSL960HM	RSL1010HM	RSL1090HM	RSL1190HM	RSL1280HM	RSL1380HM	RSL1480HM	RSL1590HM	RSL1660HM	
Nominal working condition of refrigeration	Nominal refrigerating capacity	kW	905(878)	961(932)	1014(984)	1090(1057)	1194(1158)	1277(1239)	1381(1340)	1479(1435)	1593(1545)	1664(1614)
	Rated power	kW	140(146)	148(154)	158(164)	169(176)	186(193)	198(206)	214(223)	229(238)	246(256)	257(267)
Nominal working condition of heating	Nominal heating capacity	kW	996(956)	1057(1015)	1115(1070)	1199(1151)	1313(1260)	1405(1349)	1519(1458)	1627(1562)	1752(1682)	1830(1757)
	Rated power	kW	193(191)	207(205)	221(219)	232(230)	260(257)	272(269)	300(297)	316(313)	344(341)	356(352)
Annual comprehensive performance coefficient (ACOP)		kW/kW	5.89(5.56)	5.88(5.56)	5.81(5.5)	5.88(5.56)	5.81(5.51)	5.88(5.57)	5.84(5.52)	5.88(5.57)	5.86(5.55)	5.88(5.58)
Power supply		—	3/N/PE AC380/220V 50Hz									
Safety protection		—	High/low-pressure , safety valve , water cut-off delay , anti-freezing , motor overload , open-phase and phase sequence									
Compressor	Type	—	Semi-hermetic screw type/12.5%-100% stepless adjustment									
	Qty	set	2									
Evaporator	Type	—	Flooded type (designed bearing water pressure of 1.0MPa)									
	Refrigerating water flow	m ³ /h	156(151)	165(160)	174(169)	187(182)	205(199)	220(213)	238(230)	254(247)	274(266)	286(278)
	Refrigerating water resistance	kPa	66(63)	66(63)	66(63)	66(63)	68(65)	68(65)	68(65)	72(68)	72(68)	72(68)
	Heating water flow	m ³ /h	93(189)	99(200)	104(212)	112(227)	123(249)	132(266)	142(288)	152(309)	164(332)	171(347)
Condenser	Heating water resistance	kPa	30(78)	30(78)	30(78)	30(78)	31(81)	31(81)	31(81)	33(85)	33(85)	33(85)
	Type	—	Horizontal shell and tube type (designed bearing water pressure of 1.0MPa)									
	Refrigerating water flow	m ³ /h	93(189)	99(200)	104(212)	112(227)	123(249)	132(266)	142(288)	152(309)	164(332)	171(347)
	Refrigerating water resistance	kPa	35(69)	35(69)	35(69)	35(69)	37(74)	37(74)	37(74)	37(74)	38(76)	38(76)
Total heat recovery type (optional)	Heat recovery water flow	m ³ /h	156(151)	165(160)	174(169)	187(182)	205(199)	220(213)	238(230)	254(247)	274(266)	286(278)
	Heat recovery water resistance	kPa	59(56)	59(56)	59(56)	59(56)	63(60)	63(60)	63(60)	63(60)	65(61)	65(61)
	Heat recovery Qty	kg	746	790	838	885	974	1027	1132	1218	1310	1383
	Heat recovery power	kW	959	1017	1078	1141	1251	1315	1449	1566	1685	1778
Refrigerant R22 charge Qty	Heat recovery Qty	kg	213	227	240	256	277	288	317	348	375	395
	Heat recovery water flow	m ³ /h	165	175	185	196	215	226	249	269	290	306
	Heat recovery water resistance	kPa	60	60	60	66	66	70	70	70	70	70
	Basic type	kg	280	340	340	350	370	380	390	400	410	420
Total heat recovery type	kg	305	360	370	380	410	420	430	440	460	470	

Screw Water (Ground) Source Heat Pump Unit

Screw Water (Ground) Source Heat Pump Unit (R22)

Basic type	RSL1790M	RSL1920M	RSL2050M	RSL2180M	RSL2280M	RSL2390M	RSL2860M	RSL3330M	RSL3700M
Total heat recovery type	RSL1790HM	RSL1920HM	RSL2050HM	RSL2180HM	RSL2280HM	RSL2390HM	RSL2860HM	RSL3330HM	RSL3700HM
Nominal refrigerating capacity	1787(1733)	1922(1864)	2051(1989)	2180(2115)	2284(2215)	2388(2316)	2860(2774)	3328(3228)	3700(3589)
Rated power	276(287)	298(310)	317(330)	336(349)	352(366)	372(387)	443(461)	514(535)	574(597)
Nominal heating capacity	1966(1887)	2114(2029)	2256(2166)	2398(2302)	2512(2412)	2627(2522)	3146(3020)	3661(3515)	4074(3911)
Rated power	386(382)	409(405)	448(444)	470(465)	493(488)	507(502)	616(610)	714(707)	795(787)
Annual coefficient of performance (A/COP)	5.86(5.55)	5.88(5.57)	5.83(5.52)	5.87(5.57)	5.87(5.56)	5.87(5.56)	5.86(5.54)	5.86(5.56)	5.86(5.55)
Power supply	3/N/PE AC380/220V 50Hz								
Safety protection	High-flow-pressure, oil level, safety valve, water cut-off delay, anti-freezing, motor overload, open-phase and phase sequence								
Type	Semi-hermetic screw type/12.5%-100% stepless adjustment								
City	2								
Type	Flooded type (designed bearing water pressure of 1.0MPa)								
Refrigerating water flow	307(298)	331(321)	353(342)	375(364)	393(381)	411(398)	492(477)	572(555)	636(617)
Refrigerating water resistance	77(74)	72(68)	72(68)	72(68)	72(68)	74(70)	74(70)	77(74)	83(79)
Heating water flow	184(379)	198(401)	211(428)	225(455)	235(476)	246(498)	295(596)	343(694)	381(772)
Heating water resistance	35(91)	35(91)	33(85)	33(85)	33(85)	34(87)	34(87)	35(91)	38(98)
Type	Horizontal shell and tube type (designed bearing water pressure of 1.0MPa)								
Refrigerating water flow	184(373)	198(401)	211(428)	225(455)	235(476)	246(498)	295(596)	343(694)	381(772)
Refrigerating water resistance	40(79)	38(75)	38(75)	38(75)	38(75)	39(78)	39(78)	40(79)	42(84)
Heating water flow	307(298)	331(321)	353(342)	375(364)	393(381)	411(398)	492(477)	572(555)	636(617)
Heating water resistance	68(64)	68(64)	64(60)	64(60)	64(60)	67(63)	67(63)	68(64)	72(68)
Heat recovery refrigerating capacity	1455	1533	1580	1775	1894	1981	---	---	---
Heat recovery Qty	1872	1972	2053	2278	2422	2533	---	---	---
Heat recovery power	417	439	473	503	528	552	---	---	---
Heat recovery water flow	322	339	353	392	417	436	---	---	---
Heat recovery water resistance	72	72	72	72	72	72	---	---	---
Basic type	480	500	510	510	550	550	790	840	1000
Total heat recovery type	530	530	540	550	560	570	---	---	---

Note:

- Nominal working condition of refrigeration: Outlet water temperature of chilled water is 7 °C and calculate the water flow according to "nominal refrigerating capacity" x 0.172m³(h·kW); the inlet water temperature of hot water is 18 °C under the working condition of water source heat pump and calculate the water flow according to "nominal refrigerating capacity" x 0.103 m³(h·kW); the inlet water temperature of hot water is 25 °C under the working condition of ground source heat pump and calculate the water flow according to "nominal refrigerating capacity" x 0.215 m³(h·kW);
- Nominal working condition of heating: Outlet water temperature of hot water is 45 °C and the water flow is same with the chilled water flow under the nominal working condition of refrigeration; the inlet water temperature of chilled water is 15 °C under the working condition of water source heat pump and that under the working condition of ground source heat pump is 10 °C; and the water flow is same with the hot water flow under the nominal working condition of refrigeration;
- Working condition of heat recovery: Inlet-outlet water temperature of hot water is 45/50 °C; outlet water temperature of chilled water is 7 °C; water flow is same with the chilled water flow under nominal working condition of refrigeration; the unit supplies hot water at the same time of refrigeration or heating operation, but it cannot supply hot water only;
- The outlet water temperature of chilled water is 5-15 °C under the working condition of refrigeration, the outlet water temperature of hot water ranges from 40-53 °C under the working condition of heating and that of heat recovery is 30-55 °C; the fouling coefficient of evaporator water side is 0.018m²·°C/kW and that of condenser water side is 0.44 m²·°C/kW;
- Parameters inside the () only applies to the ground source heat pump unit;
- For more detailed information including unit dimension, weight, and wiring etc., please refer to more specific large sample.

Screw Water (Ground) Source Heat Pump Unit

Unit Technical Parameter
Screw Water (Ground) Source Heat Pump Unit (R22)

Basic type	RSLB180	RSLB220	RSLB270	RSLB320	RSLB370	RSLB420	RSLB470	RSLB520	RSLB570	RSLB630	RSLB690	RSLB770	RSLB830
Total heat recovery type	RSLB180H	RSLB220H	RSLB270H	RSLB320H	RSLB370H	RSLB420H	RSLB470H	RSLB520H	RSLB570H	RSLB630H	RSLB690H	RSLB770H	RSLB830H
Nominal refrigerating capacity	186(180)	224(217)	272(264)	314(305)	365(354)	414(402)	473(459)	525(509)	571(554)	626(607)	685(664)	768(745)	835(810)
Rated power	38(40)	43(45)	52(54)	57(59)	63(66)	72(75)	86(89)	95(99)	100(104)	108(112)	118(123)	133(138)	150(156)
Nominal heating capacity	196(188)	233(224)	281(270)	333(320)	382(367)	434(417)	500(480)	556(534)	601(577)	655(629)	718(689)	805(773)	883(848)
Rated power	49(49)	54(53)	65(64)	75(74)	83(82)	95(94)	112(111)	126(125)	133(132)	142(141)	156(154)	174(172)	198(196)
Annual coefficient of performance (A/COP)	4.5(4.2)	4.81(4.56)	4.83(4.59)	5.03(4.79)	5.26(4.97)	5.23(4.95)	5.04(4.79)	5.03(4.75)	5.18(4.9)	5.27(4.99)	5.27(4.99)	5.26(5)	5.07(4.81)
Power supply	3/N/PE AC380/220V 50Hz												
Safety protection	High-flow-pressure protection, safety valve, water cut-off delay protection, anti-freezing protection, motor overload protection, open-phase and phase sequence protection												
Type	Semi-hermetic screw type/25%-100% stepless adjustment												
City	1												
Type	U-type dry shell and tube (designed bearing water pressure of 1.0MPa)												
Refrigerating water flow	32(31)	39(37)	47(45)	54(52)	63(61)	71(69)	81(79)	90(88)	98(95)	108(104)	118(114)	132(128)	144(139)
Refrigerating water resistance	55(53)	55(53)	66(63)	66(63)	66(63)	66(63)	66(63)	72(68)	72(68)	72(68)	72(68)	72(68)	72(68)
Heating water flow	19(39)	23(47)	28(57)	32(66)	38(76)	43(86)	49(99)	54(109)	59(119)	64(131)	71(143)	79(160)	86(174)
Heating water resistance	25(65)	25(65)	30(78)	30(78)	30(78)	30(78)	33(85)	33(85)	33(85)	33(85)	33(85)	33(85)	33(85)
Type	Horizontal shell and tube type (designed bearing water pressure of 1.0MPa)												
Refrigerating water flow	19(39)	23(47)	28(57)	32(66)	38(76)	43(86)	49(99)	54(109)	59(119)	64(131)	71(143)	79(160)	86(174)
Refrigerating water resistance	21(42)	21(42)	21(42)	21(42)	21(42)	21(42)	24(47)	24(47)	24(47)	27(53)	27(53)	32(63)	32(63)
Heating water flow	32(31)	39(37)	47(45)	54(52)	63(61)	71(69)	81(79)	90(88)	98(95)	108(104)	118(114)	132(128)	144(139)
Heating water resistance	36(34)	36(34)	36(34)	36(34)	36(34)	36(34)	36(34)	41(38)	41(38)	41(38)	45(43)	45(43)	54(51)
Heat recovery refrigerating capacity	143	172	205	249	281	321	369	411	452	495	548	604	659
Heat recovery Qty	195	229	274	328	369	421	487	544	592	644	713	788	869
Heat recovery power	52	57	69	79	88	100	118	133	140	149	165	184	210
Heat recovery water flow	34	39	47	56	63	72	84	94	102	111	123	136	149
Heat recovery water resistance	40	40	40	40	40	40	45	45	45	45	50	50	60
Basic type	40	46	55	64	77	84	94	102	110	120	128	142	160
Total heat recovery type	45	55	63	74	80	90	100	110	118	129	140	155	166

Note:

- Nominal working condition of refrigeration: Outlet water temperature of chilled water is 7 °C and calculate the water flow according to "nominal refrigerating capacity" x 0.172m³(h·kW); the inlet water temperature of hot water is 18 °C under the working condition of water source heat pump and calculate the water flow according to "nominal refrigerating capacity" x 0.103 m³(h·kW); the inlet water temperature of hot water is 25 °C under the working condition of ground source heat pump and calculate the water flow according to "nominal refrigerating capacity" x 0.215 m³(h·kW);
- Nominal working condition of heating: Outlet water temperature of hot water is 45 °C and the water flow is same with the chilled water flow under the nominal working condition of refrigeration; the inlet water temperature of chilled water is 15 °C under the working condition of water source heat pump and that under the working condition of ground source heat pump is 10 °C; and the water flow is same with the hot water flow under the nominal working condition of refrigeration;
- Working condition of heat recovery: Inlet-outlet water temperature of hot water is 45/50 °C; outlet water temperature of chilled water is 7 °C; water flow is same with the chilled water flow under nominal working condition of refrigeration; the unit supplies hot water at the same time of refrigeration or heating operation, but it cannot supply hot water only;
- The outlet water temperature of chilled water is 5-15 °C under the working condition of refrigeration, the outlet water temperature of hot water ranges from 40-53 °C under the working condition of heating and that of heat recovery is 30-55 °C; the fouling coefficient of evaporator water side is 0.018m²·°C/kW and that of condenser water side is 0.44 m²·°C/kW;
- Parameters inside the () only applies to the ground source heat pump unit; for more detailed information including unit dimension, weight, and wiring etc., please refer to more specific large sample.

Screw Water (Ground) Source Heat Pump Unit

Screw Water (Ground) Source Heat Pump Unit (R134a)

Basic type	RSLB420J		RSLB470J		RSLB520J		RSLB630J		RSLB690J		RSLB770J		RSLB830J		RSLB910J		RSLB960J		RSLB1010J		RSLB1090J			
	RSLB420HJ		RSLB470HJ		RSLB520HJ		RSLB630HJ		RSLB690HJ		RSLB770HJ		RSLB830HJ		RSLB910HJ		RSLB960HJ		RSLB1010HJ		RSLB1090HJ			
Total heat recovery type	-																							
Nominal capacity	414(402)		473(459)		525(509)		571(554)		626(607)		665(644)		768(745)		835(810)		906(879)		961(932)		1042(982)		1091(1058)	
Nominal refrigerating capacity	65(68)		74(77)		82(85)		89(93)		97(101)		108(110)		118(123)		128(133)		140(146)		150(156)		158(164)		170(177)	
Nominal heating capacity	434(417)		500(480)		556(534)		601(577)		655(629)		718(689)		805(773)		883(848)		946(908)		1008(968)		1060(1018)		1148(1102)	
Rated power	85(84)		98(97)		109(108)		118(117)		128(127)		141(140)		158(156)		174(172)		187(185)		200(198)		210(208)		227(225)	
Annual coefficient of performance (ACOP)	5.81(5.49)		5.82(5.51)		5.83(5.52)		5.86(5.54)		5.88(5.54)		5.88(5.57)		5.88(5.57)		5.88(5.57)		5.88(5.49)		5.88(5.49)		5.81(5.5)		5.81(5.5)	
Power supply	3/N/PE AC380/220V 50Hz																							
Safety protection	High/low-pressure, oil level, safety valve, water cut-off delay, anti-freezing, motor overload, open-phase and phase sequence																							
Compressor	Semi-hermetic screw type/25%-100% stepless adjustment																							
Type	1																							
Qty	2																							
Type	Flooded type (designed bearing water pressure of 1.0MPa)																							
Refrigerating water flow	71(69)		81(79)		90(88)		98(95)		108(104)		118(114)		132(128)		144(139)		156(151)		165(160)		174(169)		188(182)	
Refrigerating water resistance	62(59)		62(59)		64(61)		64(61)		65(62)		65(62)		66(63)		66(63)		66(63)		66(63)		66(63)		66(63)	
Heating water flow	43(86)		49(99)		54(109)		59(119)		64(131)		71(143)		79(160)		86(174)		93(189)		99(200)		104(211)		112(227)	
Heating water resistance	28(73)		28(73)		29(75)		29(75)		30(77)		30(77)		30(78)		30(78)		30(78)		30(78)		30(78)		30(78)	
Type	Horizontal shell and tube type (designed bearing water pressure of 1.0MPa)																							
Refrigerating water flow	43(86)		49(99)		54(109)		59(119)		64(131)		71(143)		79(160)		86(174)		93(189)		99(200)		104(211)		112(227)	
Refrigerating water resistance	33(65)		33(65)		34(67)		34(67)		34(68)		34(68)		35(69)		35(69)		35(69)		35(69)		35(69)		35(69)	
Heating water flow	71(69)		81(79)		90(88)		98(95)		108(104)		118(114)		132(128)		144(139)		156(151)		165(160)		174(169)		188(182)	
Heating water resistance	56(53)		56(53)		57(54)		58(54)		58(54)		59(55)		59(55)		59(56)		59(56)		59(56)		59(56)		59(56)	
Heat recovery capacity	321		363		400		444		482		543		588		647		699		741		788		844	
Heat recovery Qty	418		472		518		576		623		701		762		839		909		965		1030		1101	
Heat recovery power	97		109		118		132		141		158		174		192		210		224		242		257	
Heat recovery water flow (optional)	81		89		97		107		121		131		144		156		166		177		189		189	
Heat recovery water resistance	56		57		58		58		58		59		59		60		60		60		60		60	
Basic type	140		148		152		158		170		175		180		185		185		240		250		260	
Total heat recovery type	154		163		167		174		187		193		198		204		204		270		280		290	

Note:

- Nominal working condition of refrigeration: Outlet water temperature of chilled water is 7 °C and calculate the water flow according to "nominal refrigerating capacity" x 0.172m³/(h·kW); the inlet water temperature of hot water is 18 °C under the working condition of water source heat pump and calculate the water flow according to "nominal refrigerating capacity" x 0.103 m³/(h·kW); the inlet water temperature of hot water is 25 °C under the working condition of ground source heat pump and calculate the water flow according to "nominal refrigerating capacity" x 0.215 m³/(h·kW);
- Nominal working condition of heating: Outlet water temperature of hot water is 45 °C and the water flow is same with the chilled water flow under the nominal working condition of refrigeration; the inlet water temperature of chilled water is 15 °C under the working condition of water source heat pump and that under the nominal working condition of refrigeration; the inlet water temperature of hot water is 10 °C; and the water flow is same with the hot water flow under the nominal working condition of refrigeration;
- Working condition of heat recovery: Inlet-outlet water temperature of hot water is 5-15 °C under the working condition of refrigeration; the unit supplies hot water at the same time of refrigeration or heating operation, but it cannot supply the chilled water flow under nominal working condition of refrigeration;
- The outlet water temperature of chilled water is 5-15 °C under the working condition of refrigeration, the outlet water temperature of hot water ranges from 40-60 °C under the working condition of heating and that of heat recovery is 35-60 °C; the fouling coefficient of evaporator water side is 0.018m²·°C/kW and that of condenser water side is 0.44 m²·°C/kW;
- Parameters inside the () only applies to the ground source heat pump unit;

Screw Water (Ground) Source Heat Pump Unit

Unit Technical Parameter
Screw Water (Ground) Source Heat Pump Unit (R22)

Basic type	RSLB1190J		RSLB1280J		RSLB1380J		RSLB1480J		RSLB1590J		RSLB1660J		RSLB1790J		RSLB1920J		RSLB2100J		RSLB2280J		RSLB2430J		RSLB2560J	
	RSLB1190HJ		RSLB1280HJ		RSLB1380HJ		RSLB1480HJ		RSLB1590HJ		RSLB1660HJ		RSLB1790HJ		RSLB1920HJ		RSLB2100HJ		RSLB2280HJ		RSLB2430HJ		RSLB2560HJ	
Total heat recovery type	-																							
Nominal capacity	1194(1158)		1277(1239)		1387(1345)		1479(1435)		1566(1519)		1684(1614)		1790(1736)		1921(1869)		2111(2048)		2279(2211)		2432(2359)		2574(2497)	
Nominal refrigerating capacity	186(193)		199(207)		216(225)		230(239)		244(254)		259(269)		279(290)		300(312)		326(339)		352(366)		376(391)		396(412)	
Nominal heating capacity	1247(1197)		1331(1278)		1438(1380)		1531(1470)		1622(1557)		1737(1668)		1866(1791)		1999(1919)		2202(2114)		2377(2282)		2537(2436)		2680(2573)	
Rated power	246(244)		263(260)		281(278)		298(295)		315(312)		343(340)		368(365)		393(389)		430(428)		464(459)		496(491)		522(517)	
Annual coefficient of performance (ACOP)	5.82(5.51)		5.82(5.51)		5.84(5.53)		5.86(5.55)		5.88(5.51)		5.81(5.51)		5.82(5.51)		5.82(5.51)		5.87(5.56)		5.87(5.56)		5.87(5.56)		5.89(5.58)	
Power supply	3/N/PE AC380/220V 50Hz																							
Safety protection	High/low-pressure, oil level, safety valve, water cut-off delay, anti-freezing, motor overload, open-phase and phase sequence																							
Compressor	Semi-hermetic screw type/12.5%-100% stepless adjustment																							
Type	2																							
Qty	2																							
Type	Falling film type (designed bearing water pressure of 1.0MPa)																							
Refrigerating water flow	205(199)		220(213)		239(231)		254(247)		269(261)		286(278)		308(299)		330(320)		363(352)		392(380)		418(406)		443(429)	
Refrigerating water resistance	68(65)		68(65)		72(68)		72(68)		72(68)		72(68)		77(74)		77(74)		78(75)		78(75)		79(76)		79(76)	
Heating water flow	123(249)		132(249)		143(289)		152(309)		161(327)		171(347)		184(373)		198(401)		217(440)		235(475)		250(507)		265(537)	
Heating water resistance	31(81)		31(81)		31(81)		33(85)		33(85)		33(85)		35(91)		35(91)		36(92)		36(92)		36(94)		36(94)	
Type	Horizontal shell and tube type (designed bearing water pressure of 1.0MPa)																							
Refrigerating water flow	123(249)		132(249)		143(289)		152(309)		161(327)		171(347)		184(373)		198(401)		217(440)		235(475)		250(507)		265(537)	
Refrigerating water resistance	37(74)		37(74)		37(74)		37(74)		38(76)		38(76)		38(76)		40(79)		40(79)		40(80)		41(81)		41(81)	
Heating water flow	205(199)		220(213)		239(231)		254(247)		269(261)		286(278)		308(299)		330(320)		363(352)		392(380)		418(406)		443(429)	
Heating water resistance	63(60)		63(60)		63(60)		65(61)		65(61)		65(61)		68(64)		68(64)		68(65)		68(65)		69(65)		69(65)	
Heat recovery capacity	924		987		1066		1136		1219		1285		1380		1483		1632		1761		1880		1992	
Heat recovery Qty	1195		1274		1372		1458		1556		1662		1783		1911		2105		2271		2426		2566	
Heat recovery power	271		289		306		322		337		357		403		428		473		510		546		574	
Heat recovery water flow (optional)	206		219		236		251		268		286		307		329		362		391		417		441	
Heat recovery water resistance	66		66		66		66		70		70		72		72		73		73		73		73	
Basic type	270		280		290		300		310		315		320		335		350		360		380		400	
Total heat recovery type	300		310		330		340		350		360		360		380		460		475		490		500	

Note:

- Nominal working condition of refrigeration: Outlet water temperature of chilled water is 7 °C and calculate the water flow according to "nominal refrigerating capacity" x 0.172m³/(h·kW); the inlet water temperature of hot water is 18 °C under the working condition of water source heat pump and calculate the water flow according to "nominal refrigerating capacity" x 0.103 m³/(h·kW); the inlet water temperature of hot water is 25 °C under the working condition of ground source heat pump and calculate the water flow according to "nominal refrigerating capacity" x 0.215 m³/(h·kW);
- Nominal working condition of heating: Outlet water temperature of hot water is 45 °C and the water flow is same with the chilled water flow under the nominal working condition of refrigeration; the inlet water temperature of chilled water is 15 °C under the working condition of water source heat pump and that under the nominal working condition of refrigeration; the inlet water temperature of hot water is 10 °C; and the water flow is same with the hot water flow under the nominal working condition of refrigeration;
- Working condition of heat recovery: Inlet-outlet water temperature of hot water is 5-15 °C under the working condition of refrigeration; the unit supplies hot water at the same time of refrigeration or heating operation, but it cannot supply the chilled water flow under nominal working condition of refrigeration;
- The outlet water temperature of chilled water is 5-15 °C under the working condition of refrigeration, the outlet water temperature of hot water ranges from 40-53 °C under the working condition of heating and that of heat recovery is 30-55 °C; the fouling coefficient of evaporator water side is 0.018m²·°C/kW and that of condenser water side is 0.44 m²·°C/kW;
- Parameters inside the () only applies to the ground source heat pump unit; for more detailed information including unit dimension, weight, and wiring, etc., please refer to more specific large sample.

Scroll Water-cooled Chilled (Hot) Water Unit



Unit Feature

1. Environmental protection refrigerant

In order to protect the ozone layer, reduce the atmospheric greenhouse effect and realize the vision of protecting the environment, the unit can choose R410A environmentally friendly refrigerant, with the ozone depletion potential of 0, being safe, non-toxic, nonflammable and green, meeting the current development trend of international environmental protection.

2. Modular design

The unit adopts modular design, enjoying flexible combination and good scalability. Up to 8 basic modules can be combined to control. The unit suits for applications with the cooling load from 75~3300kW, and the span of each level of refrigerating capacity is 10~20RT, so as to meet the needs of various users.

3. Dual-compressor parallel design

The unit adopts the dual-compressor parallel connection technology. When only a single compressor is used, the compressor uses twice the heat exchange area, which greatly increases the unit energy efficiency ratio of partial load. At the same time, during partial load operation, the unit can automatically balance the running time of compressor and start two compressors alternately, so as to level the wear of each compressor and improve the service life of entire machine.

4. Highly intelligent control system

Adopt micro-computer controller to implement real-time monitoring and analysis of various operation parameters of the unit, making the unit always at the best running state. The system is equipped with Chinese LCD display and user-friendly interface, convenient to operate.

5. Excellent design and manufacturing

The unit adopts industry-leading system design, professional heat exchanger, and highly intelligent control system, so as to maintain its optimal running state, have higher energy efficiency ratio and operate more stably.

Unit Model Denotation Method

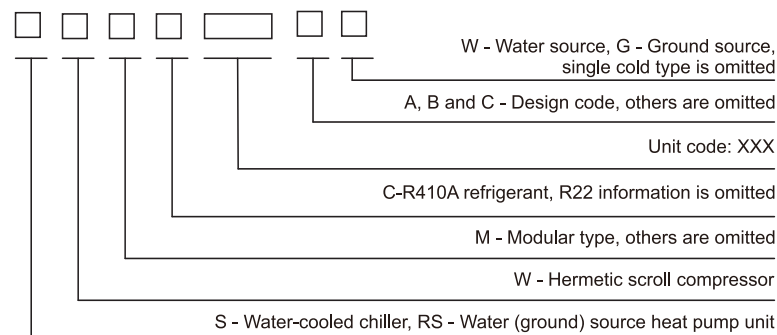

Example: RSWMC040AW indicates scroll water source heat pump unit using scroll compressor, R410A refrigerant, with the model code of 040 and design code of A.

Scroll Water-cooled Chilled (Hot) Water Unit

Unit Technical Parameter

Technical Parameters for Scroll Water-cooled Chiller

Basic type			SWMC020	SWMC030	SWMC040A
Nominal working condition of refrigeration	Nominal refrigerating capacity	kW	75	110	150
	Rated power	10 ³ kcal/h	6.5	9.5	12.9
	Rated power	kW	14.5	21.5	29.0
	COP	kW/kW	5.17	5.11	5.17
	Max. running current	A	2×24	3×24	4×24
	Recommended wiring (copper core)	mm ²	16	25	35
	Power supply	--	3/N/PE AC380/220V 50Hz		
	Safety protection	--	High/low-pressure, safety valve, water cut-off delay, anti-freezing, motor overload, open-phase and phase sequence		
Compressor	Type	--	Hermetic scroll type		
	Qty	set	2	3	4
Evaporator	Type	--	U-type dry shell and tube (designed bearing water pressure of 1.0MPa)		
	Water flow	m ³ /h	13	19	26
	Water resistance	kPa	65	65	70
	Inlet/outlet water pipe joint	--	DN65	DN65	DN80
Condenser	Type	--	Horizontal shell and tube type (designed bearing water pressure of 1.0MPa)		
	Water flow	m ³ /h	16	24	32
	Water resistance	kPa	30	30	30
	Inlet/outlet water pipe joint	--	DN65	DN65	DN80
	Refrigerant R410A charge Qty	kg	16	16+9	15+15
	Unit weight	kg	550	710	950
	Operating weight	kg	600	770	1020

Note:

- Nominal working condition of refrigeration: Outlet water temperature of chilled water is 7 °C and calculate the water flow according to "nominal refrigerating capacity" × 0.172m³(h · kW); inlet water temperature of cooling water is 30 °C and calculate the water flow according to nominal refrigerating capacity" × 0.215m³(h · kW);
- The outlet water temperature of chilled water is 5-15 °C; the fouling coefficient of evaporator water side is 0.018m²·°C/kW and that of condenser water side is 0.44m²·°C/kW;
- It is recommended that when the wiring temperature is 30 °C, PVC insulated power cable (copper wire) and splice cable shall be the iso-diameter wire produced by the same company.
- For dimension and other parameters of unit, please refer to the unit dimensional figure.

Technical Parameters for Scroll Water (Ground) Source Heat Pump Unit

Basic type		Water source (groundwater type)			Ground source (buried pipe type)			
		RSWC020W	RSWC030W	RSWC040AW	RSWMC020G	RSWMC030G	RSWMC040AG	
Nominal working condition of refrigeration	Nominal refrigerating capacity	kW	81.0	121.0	162.0	79.0	117.0	157.0
	Rated power	kW	13.0	19.5	26.0	13.5	20.0	27.0
	Nominal heating capacity	kW	86.0	128.0	172.0	83.0	123.0	165.0
Basic type	Rated power	kW	18.0	27.0	36.0	18.0	27.0	36.0
	Annual comprehensive performance coefficient (ACOP)	kW/kW	5.59	5.56	5.59	5.30	5.28	5.27
	Max. running current	A	2×24	3×24	4×24	2×24	3×24	4×24
	Recommended wiring (copper core)	mm ²	16	25	35	16	25	35
	Power supply	--	3/N/PE AC380/220V 50Hz					
	Safety protection	--	High/low-pressure, safety valve, water cut-off delay, anti-freezing, motor overload, open-phase and phase sequence					
Compressor	Type	--	Hermetic scroll type					
	Qty	Set	2	3	4	2	3	4
Evaporator	Type	--	U-type dry shell and tube (designed bearing water pressure of 1.0MPa)					
	Refrigerating water flow	m ³ /h	14	21	28	14	20	27
	Refrigerating water resistance	kPa	72	72	77	68	68	74
	Heating water flow	m ³ /h	8	12	17	17	25	34
	Heating water resistance	kPa	33	33	35	85	85	91
	Inlet/outlet water pipe joint	--	DN65	DN65	DN80	DN65	DN65	DN80
Condenser	Type	--	Horizontal shell and tube type (designed bearing water pressure of 1.0MPa)					
	Refrigerating water flow	m ³ /h	8	12	17	17	25	34
	Refrigerating water resistance	kPa	16	16	16	32	32	32
	Heating water flow	m ³ /h	14	21	28	14	20	27
	Heating water resistance	kPa	27	27	27	26	26	26
	Inlet/outlet water pipe joint	--	DN65	DN65	DN80	DN65	DN65	DN80
	Refrigerant R410A charge Qty	kg	16	16+9	15+15	16	16+9	15+15
	Unit weight	kg	550	710	950	550	710	950
	Operating weight	kg	600	770	1020	600	770	1020

Note:

- Nominal working condition of refrigeration: Outlet water temperature of chilled water is 7 °C and calculate the water flow according to "nominal refrigerating capacity" × 0.172m³(h·kW); the inlet water temperature of hot water is 18 °C under the working condition of water source heat pump and calculate the water flow according to "nominal refrigerating capacity" × 0.103 m³(h·kW); the inlet water temperature of hot water is 25 °C under the working condition of ground source heat pump and calculate the water flow according to "nominal refrigerating capacity" × 0.215 m³(h·kW);
- Nominal working condition of heating: Outlet water temperature of hot water is 45 °C and the water flow is same with the chilled water flow under the nominal working condition of refrigeration; the inlet water temperature of chilled water is 15 °C under the working condition of water source heat pump and that under the working condition of ground source heat pump is 10 °C; and the water flow is same with the hot water flow under the nominal working condition of refrigeration;
- The outlet water temperature of chilled water is 5-15 °C under the working condition of refrigeration, the outlet water temperature of hot water ranges from 40-55 °C under the working condition of heating; the fouling coefficient of evaporator water side is 0.018m²·°C/kW and that of condenser water side is 0.44m²·°C/kW;
- It is recommended that when the wiring temperature is 30 °C, PVC insulated power cable (copper wire) and splice cable shall be the iso-diameter wire produced by the same company.
- Parameters inside the () only applies to the ground source heat pump unit; for more detailed information including unit dimension, please refer to the large sample.

Variable Frequency Falling-film Screw Chiller



Unit Feature

1. Environment-friendly refrigerant: Safe, non-toxic, nonflammable, and environmental-friendly.
2. Variable frequency compressor: Stronger motor insulation and high reliability; 20~80Hz stepless variable frequency adjustment; high water temperature control precision;
3. Variable content ratio: The compressor's internal volumetric ratio (Vi) is adjustable, the unit maintains optimal compression efficiency within the operating range, and the partial load performance factor (IPLV) is 13% higher than that of conventional compressors;
4. Falling-film evaporator: Small bubble resistance, high heat exchange efficiency and good oil return performance;
5. One fixed and one variable + dual-compressor parallel: Adopt the design of one fixed-frequency compressor and one variable frequency compressor, which inherits the advantages of high COP of fixed-frequency unit and high IPLV of variable frequency compressor.

Unit Model Denotation Method

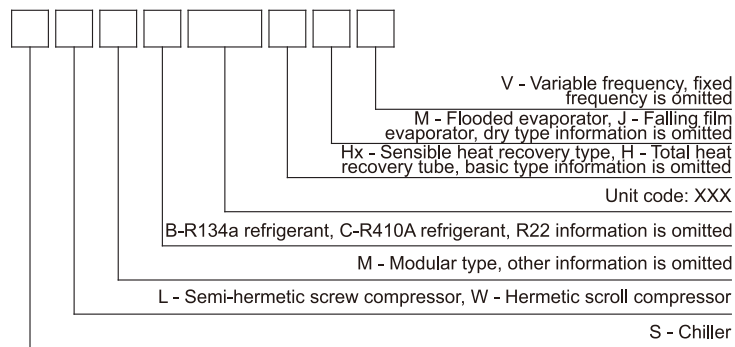

Example: SLB920JV indicates variable frequency falling film screw chiller using R134a refrigerant, with the model code of 920.

Variable Frequency Falling-film Screw Chiller

Technical Parameters

Unit model		SLB870JV	SLB920JV	SLB980JV	SLB1050JV	SLB1150JV	SLB1230JV	SLB1330JV	SLB1420JV	SLB1530JV	
Nominal working condition of refrigerator	Nominal refrigerating capacity	kW	873	925	985	1055	1154	1233	1332	1422	1531
		10 ³ kcal/h	75	80	85	91	99	106	115	122	132
	Rated power	kW	160	169	179	191	208	223	240	258	278
	COP	kW/kW	5.45	5.47	5.50	5.52	5.54	5.52	5.55	5.51	5.50
	IPLV	kW/kW	7.74	7.77	7.81	7.84	7.87	7.97	8.00	7.94	7.94
Max. running current	A	173+180	209+180	209+218	236+218	236+241	276+241	276+258	276+298	307+298	
Recommended wiring (copper core)	mm ²	95+95	95+95	95+95	120+95	120+120	150+120	150+150	150+185	185+185	
Power supply	--	3/N/PE AC380/220V 50Hz									
Safety protection	--	High/low-pressure , oil level , safety valve , water cut-off delay , anti-freezing , motor overload , open-phase and phase sequence									
Compressor	Type	--	Semi-hermetic screw type/12.5%-100% stepless variable frequency adjustment								
	Qty	Set	2								
Evaporator		--	Falling film screw (designed bearing water pressure of 1.0MPa)								
	Water flow	m ³ /h	150	159	169	181	198	212	229	245	263
	Water pressure drop	kPa	60	60	60	60	62	62	62	65	65
Condenser		--	Horizontal shell and tube type (designed bearing water pressure of 1.0MPa)								
	Water flow	m ³ /h	188	199	212	227	248	265	286	306	329
	Water pressure drop	kPa	66	66	66	66	70	70	70	70	72
Refrigerant R134a charge Qty	kg	240	250	255	260	270	280	290	300	310	
Unit weight	kg	5050	5700	5950	6290	6400	6650	6950	7200	7400	
Operating weight	kg	5500	6250	6500	6850	6950	7250	7450	7700	7900	

Note:

1. Nominal working condition of refrigeration: Outlet water temperature of chilled water is 7 °C and calculate the water flow according to "nominal refrigerating capacity" x 0.172m³(h • kW); inlet water temperature of cooling water is 30 °C and calculate the water flow according to nominal refrigerating capacity" x 0.215m³(h • kW);
2. The outlet water temperature of chilled water is 5-15 °C; the fouling coefficient of evaporator water side is 0.018m²• °C/kW and that of condenser water side is 0.44m²• °C/kW;
3. It is recommended that when the wiring temperature is 30 °C, PVC insulated power cable (copper wire) and splice cable shall be the iso-diameter wire produced by the same company.
4. For dimension and other parameters of unit, please refer to the unit dimensional figure.

Industrial Chiller



Unit Feature

1. Whole-year refrigeration function

The unit controls the system condensing pressure by adjusting the cooling water by-pass valve, so as to provide low-temperature cold source all the year round. It is widely applied to various industrial cooling systems.

2. Environmental protection refrigerant

In order to protect the ozone layer, reduce the atmospheric greenhouse effect and realize the vision of protecting the environment, the unit can choose R134a environmentally friendly refrigerant, with the ozone depletion potential of 0, being safe, non-toxic, nonflammable and green, meeting the current development trend of international environmental protection.

3. Highly intelligent control system

Adopt industrial controller, equipped with Chinese display and user-friendly interface, convenient to operate.

4. Excellent design and manufacturing

The unit adopts industry-leading system design, professional heat exchanger, and highly intelligent control system, so as to maintain its optimal running state, have higher energy efficiency ratio and operate more stably.

5. Reliable product quality

Each unit is tested in strict accordance with the provisions of national standards by using the full-performance test bench designed and produced by Hefei General Machinery Research Institute. It is permitted to leave the factory only when all performance indexes reach or exceed the national standard requirements.

Unit Model Denotation Method

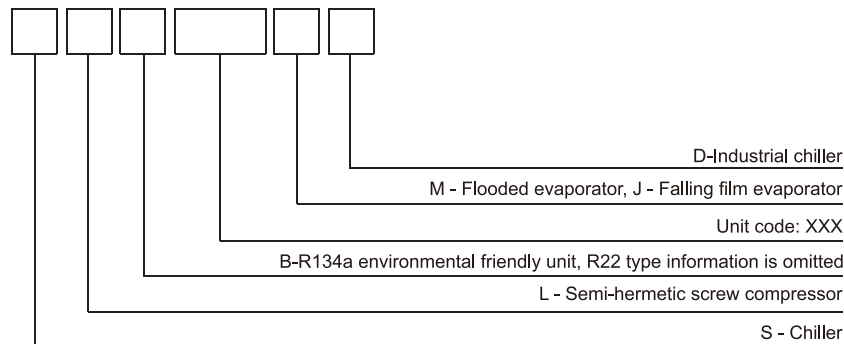

Example: SL610MD indicates industrial water-cooled screw chiller using flooded evaporator, with the model code of 610.

Industrial Chiller

Unit Technical Parameter

Industrial Chiller (R22 Dry Type)

Unit model	Type	SL120D	SL150D	SL180D	SL210D	SL240D	SL270D	SL310D	SL350D	SL390D	SL430D	SL470D	SL510D	SL560D	
Nominal refrigerating capacity	kW	117	151	175	213	246	277	311	345	384	425	465	516	554	
	10 ³ kcal/h	10	13	15	18	21	24	27	30	33	37	40	44	48	
Rated power	kW	35	45	52	63	73	83	84	94	105	117	127	141	148	
COP	kW/kW	3.34	3.35	3.36	3.38	3.36	3.33	3.70	3.67	3.65	3.63	3.66	3.65	3.74	
Refrigerant R22 charge Qty	kg	33	41	49	59	66	76	85	95	103	114	125	140	151	
Max. running current	A	82	109	109	134	155	169	188	218	230	249	268	319	319	
Recommended wiring (copper core)	mm ²	25	35	35	50	70	95	95	120	150	185	240	240	240	
Power supply	3/N/PE AC380/220V 50Hz														
Safety protection	High/low-pressure , safety valve, water cut-off delay , anti-freezing , motor overload , open-phase and phase sequence														
Compressor	Type	Semi-hermetic screw type													
	Qty	set													
Evaporator	Type	U-type dry shell and tube (designed bearing water pressure of 1.0MPa)													
	Water flow	m ³ /h	23	29	34	41	47	53	60	66	74	82	90	99	107
	Water resistance	kPa	55	55	55	60	60	60	55	55	55	55	60	60	60
	Inlet/outlet water pipe joint	DN80			DN100			DN125			DN150				
Condenser	Type	Horizontal shell and tube type (designed bearing water pressure of 1.0MPa)													
	Water flow	m ³ /h	26	34	39	47	55	62	68	76	84	93	102	113	121
	Water resistance	kPa	35	35	35	35	35	35	40	40	40	45	45	55	55
	Inlet/outlet water pipe joint	DN80			DN100			DN125			DN150				
Overall dimension	L	mm	3000	3000	3000	3000	3300	3300	3300	3600	3600	3600	3600	3600	
	W	mm	800	800	800	800	800	1050	1050	1050	1050	1100	1100	1100	
	H	mm	1700	1700	1700	1700	1700	1700	1700	1700	2000	2000	2000	2000	
Unit weight	kg	850	1000	1200	1400	1500	1700	1900	2100	2250	2500	2800	3050	3260	
Operating weight	kg	920	1080	1300	1500	1620	1840	2050	2270	2440	2710	3000	3300	3540	

Industrial Chiller (R22 Flooded Type)

Unit model	Type	SL610MD	SL660MD	SL710MD	SL760MD	SL810MD	SL860MD	SL940MD	SL1020MD	SL1100MD	SL1180MD	SL1260MD	SL1340MD	
Nominal refrigerating capacity	kW	606	664	705	766	815	856	937	1013	1102	1186	1268	1337	
	10 ³ kcal/h	52	57	61	66	70	74	81	87	95	102	109	115	
Rated power	kW	147	166	170	191	200	210	230	248	273	289	314	320	
COP	kW/kW	4.12	4.00	4.14	4.01	4.07	4.07	4.07	4.08	4.03	4.10	4.03	4.17	
Refrigerant R22 charge Qty	kg	280	340	340	350	370	380	390	400	410	420	480	500	
Max. running current	A	158+206	173+206	206+206	206+221	221+221	221+259	259+259	259+287	287+287	287+320	320+320	320+366	
Recommended wiring (copper core)	mm ²	70+95	95+95	95+95	95+120	120+120	120+150	150+150	150+185	185+185	185+240	240+240	240+240	
Power supply	3/N/PE AC380/220V 50Hz													
Safety protection	High/low-pressure , oil level , safety valve, water cut-off delay , anti-freezing , motor overload , open-phase and phase sequence													
Compressor	Type	Semi-hermetic screw type												
	Qty	Set												
Evaporator	Type	Flooded type (designed bearing water pressure of 1.0MPa)												
	Water flow	m ³ /h	117	128	136	148	157	165	181	195	212	228	244	258
	Water resistance	kPa	55	55	55	55	57	57	57	60	60	60	65	65
	Inlet/outlet water pipe joint	DN150						DN200						
Condenser	Type	Horizontal shell and tube type (designed bearing water pressure of 1.0MPa)												
	Water flow	m ³ /h	130	143	151	165	175	183	201	217	237	254	272	285
	Water resistance	kPa	60	60	60	60	65	65	65	65	68	68	70	70
	Inlet/outlet water pipe joint	DN150						DN200						
Overall dimension	L	mm	4100	4100	4100	4100	4100	4100	4100	4300	4300	4300	4400	
	W	mm	1400	1400	1400	1400	1550	1650	1650	1600	1700	1700	1700	
	H	mm	1750	1800	1800	1800	1850	1800	1900	1950	2000	2000	2100	
Unit weight	kg	4400	4950	5150	5400	5500	5900	6350	6850	7200	7300	7500	8800	
Operating weight	kg	4900	5450	5650	5900	6000	6400	6850	7350	7700	7800	8000	9300	

Note:

- Nominal working condition of refrigeration: Inlet/outlet water temperature of chilled water is 5/0 °C and that of cooling water is 30/35 °C; the chilled water is ethylene glycol solution with the mass concentration of 16%;
- The outlet water temperature of unit is -9-10 °C and the mass concentration of ethylene glycol water solution shall be prepared according to the physical property of ethylene glycol solution; the fouling coefficient of evaporator water side is 0.018 m²·°C/kW and that of condenser water side is 0.44m²·°C/kW;
- It is recommended that when the wiring temperature is 30 °C, PVC insulated power cable (copper wire) shall be used and splice cable shall be the iso-diameter wire produced by the same company .

Industrial Chiller

Industrial Chiller (R134a Dry Type)

Item	Type	SLB120D	SLB150D	SLB180D	SLB210D	SLB240D	SLB270D	SLB310D	SLB350D	SLB390D	SLB430D	SLB470D	SLB510D	SLB560D	
Nominal refrigerating capacity	kW	126	145	175	208	238	270	313	356	385	423	465	510	562	
	10 ³ kcal/h	10.8	12.5	15.1	17.9	20.5	23.2	26.9	30.6	33.1	36.4	40.0	43.9	48.3	
Rated power	kW	37	42	51	56	65	73	85	96	101	110	120	132	148	
COP	kW/kW	3.40	3.45	3.43	3.71	3.66	3.69	3.68	3.70	3.81	3.84	3.87	3.86	3.79	
Refrigerant R134a charge Qty	kg	40	46	55	64	77	84	94	102	110	120	128	142	160	
Max. running current	A	94	94	111	139	153	174	184	212	235	245	273	337	337	
Recommended wiring (copper core)	mm ²	35	35	50	70	70	95	95	120	120	150	185	240	240	
Power supply	3 / N / PE AC380 / 220V 50Hz														
Safety protection	High/low-pressure , safety valve , water cut-off delay , anti-freezing , motor overload , open-phase and phase sequence														
Compressor	Type	Semi-hermetic screw type													
	Qty	Set													
Evaporator	Type	U-type dry shell and tube (designed bearing water pressure of 1.0MPa)													
	Water flow	m ³ /h	24	28	34	40	46	52	60	69	74	81	90	98	108
	Water resistance	kPa	45	45	55	55	55	55	60	60	60	60	60	60	60
Condenser	Inlet/outlet water pipe joint	DN80			DN100			DN125			DN150				
	Type	Horizontal shell and tube type (designed bearing water pressure of 1.0MPa)													
	Water flow	m ³ /h	28	32	39	45	52	59	69	78	84	92	101	110	122
Water resistance	kPa	35	35	35	35	35	35	40	40	40	45	45	55	55	
Overall dimension	Inlet/outlet water pipe joint	DN80			DN100			DN125			DN150				
	L	mm	3000	3100	3100	3100	3200	3200	3200	3400	3400	3400	3400	3400	3400
	W	mm	1000	1050	1050	1150	1150	1150	1200	1200	1300	1300	1300	1300	1300
H	mm	1550	1550	1650	1650	1700	1700	1800	1800	1800	1800	1900	1900	2000	
Unit weight	kg	950	1100	1300	1500	1650	1850	2050	2250	2450	2700	3050	3300	3560	
Operating weight	kg	1020	1180	1400	1600	1770	1990	2200	2420	2640	2910	3250	3550	3840	

Industrial Chiller (R134a Falling Film Type)

Item	Type	SLB610JD	SLB660JD	SLB710JD	SLB760JD	SLB810JD	SLB860JD	SLB940JD	SLB1020JD	SLB1100JD	SLB1180JD	SLB1260JD	SLB1340JD	
Nominal refrigerating capacity	kW	612	657	708	756	807	857	946	1017	1094	1175	1246	1300	
	10 ³ kcal/h	53	57	61	65	69	74	81	87	94	101	107	112	
Rated power	kW	149	160	172	183	195	207	232	247	256	274	292	311	
COP	kW/kW	4.10	4.10	4.11	4.13	4.13	4.14	4.07	4.11	4.27	4.28	4.26	4.18	
Refrigerant R134a charge Qty	kg	240	250	255	260	270	280	290	300	310	315	320	335	
Max. running current	A	160+181	181+181	181+181	181+199	199+238	238+238	238+267	267+267	267+304	304+331	331+331	331+331	
Recommended wiring (copper core)	mm ²	70+95	95+95	95+95	95+95	95+120	120+120	120+150	150+150	150+185	185+240	240+240	240+240	
Power supply	3/N/PE AC380/220V 50Hz													
Safety protection	High/low-pressure , oil level , safety valve , water cut-off delay , anti-freezing , motor overload , open-phase and phase sequence													
Compressor	Type	Semi-hermetic screw type												
	Qty	Set												
Evaporator	Type	Falling film type (designed bearing water pressure of 1.0MPa)												
	Water flow	m ³ /h	118	126	136	146	155	165	182	196	211	226	240	250
	Water resistance	kPa	60	60	60	60	62	62	62	64	64	64	64	64
Condenser	Inlet/outlet water pipe joint	DN150					DN200							
	Type	Horizontal shell and tube type (designed bearing water pressure of 1.0MPa)												
	Water flow	m ³ /h	131	140	151	161	172	183	202	217	232	249	264	277
Water resistance	kPa	60	64	64	64	68	68	68	68	70	70	70	70	
Overall dimension	Inlet/outlet water pipe joint	DN150					DN200							
	L	mm	4500	4500	4500	4500	4500	4500	4500	4500	4500	4500	4500	
	W	mm	1400	1400	1400	1400	1455	1455	1520	1520	1660	1660	1660	
H	mm	1750	1750	1750	1750	1800	1800	1850	1850	1900	1900	1900	1900	
Unit weight	kg	5050	5700	5950	6290	6400	6650	6950	7200	7400	7500	7700	9050	
Operating weight	kg	5500	6250	6500	6850	6950	7250	7450	7700	7900	8000	8200	9550	

Note:

- Nominal working condition of refrigeration: Inlet/outlet water temperature of chilled water is 5/0 °C and that of cooling water is 30/35 °C; the chilled water is ethylene glycol solution with the mass concentration of 16%;
- The outlet water temperature of unit is -9-10 °C and the mass concentration of ethylene glycol water solution shall be prepared according to the physical property of ethylene glycol solution; the fouling coefficient of evaporator water side is 0.018m²·°C/kW and that of condenser water side is 0.44m²·°C/kW;
- It is recommended that when the wiring temperature is 30 °C, PVC insulated power cable (copper wire) and splice cable shall be the iso-diameter wire produced by the same company.

Centrifugal Chiller



Unit Feature

- Two-stage compression centrifuge, with second vapor injection economizer and high cycle efficiency
- Falling film evaporator, with recycling injection pump, being efficient and economic
- High-efficient condenser, with built-in guide plate and subcooler, being efficient and economic
- High-speed ball/ball bearing, with high-precision helical gear, enjoying low mechanical loss
- Large-screen touch control system, being scientific in control, intuitive and easy to use

Unit Model Denotation Method

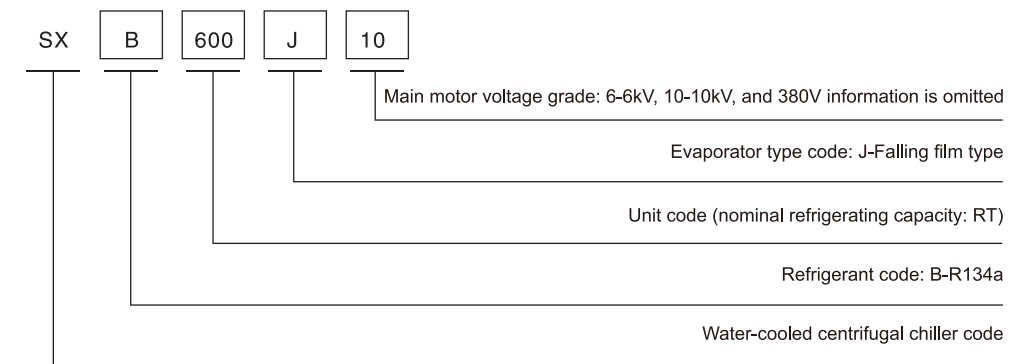

Example: SxB600HJ10 indicates that the nominal refrigerating capacity is 600RT, refrigerant is R134a, falling film evaporator is used, main motor voltage is 10kV, equipped with water-cooled centrifugal chiller having total heat recovery function.

Centrifugal Chiller

Unit Technical Parameter

Unit model		SXB500J	SXB550J	SXB600J	SXB650J	SXB700J	SXB750J	SXB800J	SXB850J	SXB900J
Refrigerating capacity	RT	500	550	600	650	700	750	800	850	900
	kW	1758	1934	2110	2285	2461	2637	2813	2989	3165
	10 ³ kcal/h	151	166	181	197	212	227	242	257	272
Motor	Power	kW								
	Power supply	/								
	Cooling mode	/								
Performance coefficient		kW/kW								
Refrigerant R134a charge Qty										
Evaporator	Cold water flow	m ³ /h								
	Cold water pressure drop	kPa								
	Number of pass	/								
	Inlet/outlet temperature of chilled water	°C								
	Condenser pipe size	/								
Condenser	Cooling water flow	m ³ /h								
	Cooling water pressure drop	kPa								
	Number of pass	/								
	Inlet/outlet temperature of cold water	°C								
	Condenser pipe size	/								
Unit dimension	L	mm								
	W	mm								
	H	mm								
Weight	Unit shipping weight	kg								
	Unit operating weight	kg								

Unit model		SXB950J	SXB1000J	SXB1100J	SXB1200J	SXB1300J	SXB1400J	SXB1500J	SXB1600J	
Refrigerating capacity	RT	950	1000	1100	1200	1300	1400	1500	1600	
	kW	3341	3516	3867	4220	4572	4923	5276	5627	
	10 ³ kcal/h	287	302	333	363	393	423	454	484	
Motor	Power	kW								
	Power supply	/								
	Cooling mode	/								
Performance coefficient		kW/kW								
Refrigerant R134a charge Qty										
Evaporator	Cold water flow	m ³ /h								
	Cold water pressure drop	kPa								
	Number of pass	/								
	Inlet/outlet temperature of chilled water	°C								
	Condenser pipe size	/								
Condenser	Cooling water flow	m ³ /h								
	Cooling water pressure drop	kPa								
	Number of pass	/								
	Inlet/outlet temperature of cold water	°C								
	Condenser pipe size	/								
Unit dimension	L	mm								
	W	mm								
	H	mm								
Weight	Unit shipping weight	kg								
	Unit operating weight	kg								

Note:

- Above parameters shall be determined according to the following working conditions: Inlet/outlet water temperature of cold water is 12/7 °C and that of cooling water is 32/37 °C; the fouling coefficient of cooling water side is 0.086m²·°C/kW and that of chilled water is 0.044m²·°C/kW.
- The design pressure of chilled water and cooling water side is 1MPa. If working pressure higher than 1 MPa is required, please specify at the time of ordering.

Magnetic Levitation Variable Frequency Centrifugal Chiller

Unit Feature

- Complete energy saving
- Highly integrated
- Environmental protection and lower operation noise
- Oil-free system, easy to maintain

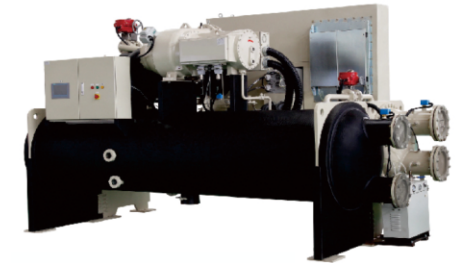

Unit Model Denotation Method

SM B 400 J V

- Variable-frequency operation
- Evaporator type code: J-falling film type
- Unit code (nominal refrigerating capacity: RT)
- Refrigerant code: R134a
- Water-cooled magnetic levitation variable frequency centrifugal chiller code

Parameter		SMB400JV	SMB450JV	SMB500JV	SMB800JV	SMB900JV	SMB1000JV
Nominal refrigerating capacity	kW	1406	1582	1758	2813	3164	3516
	10 ³ kcal/h	121	136	151	242	272	302
	RT	400	450	500	800	900	1000
Nominal power input	kW	210	240	272	420	480	544
Refrigerant type	-	R134a	R134a	R134a	R134a	R134a	R134a
Refrigerant charge	kg	360	400	450	700	800	900
COP	-	6.70	6.59	6.46	6.70	6.59	6.46
AHRI IPLV	-	11.32	11.84	11.17	11.87	11.60	11.17
Starting current	A	230	230	230	230	230	230
Max. current	A	570	570	570	2×570	2×570	2×570
Max. power input	kW	300	300	300	2×300	2×300	2×300
Evaporator	Flow	m ³ /h					
	Pressure loss	kPa					
	Nominal interface	DN					
Condenser	Flow	mm					
	Pressure loss	m ³ /h					
	Nominal interface	kPa					
Outline dimensions	L	DN					
	W	mm					
	H	mm					
Install dimensions	Position D	mm					
	Position E	mm					
Weight	Unit shipping weight	kg					
	Unit operating weight	kg					
Noise	dB	75	75	75	75	75	75

- Note: (1) Outlet water temperature of chilled water is 7 °C and calculate the water flow according to "nominal refrigerating capacity" × 0.172 m³/h × kW; inlet water temperature of cooling water is 30 °C, and calculate the water flow according to "nominal refrigerating capacity" × 0.215 m³/h × kW;
 (2) Fouling coefficient of cooling water side is 0.044 m² · °C/kW and that of chilled water side is 0.0176 m² · °C/kW;
 (3) COP and GB IPLV are tested according to GB/T 18430.1, and AHRI IPLV is tested according to AHRI Standard 550/590;
 (4) The design pressure of water side is 1MPa. If working pressure higher than 1 MPa is required, please specify at the time of ordering.

Unitary Air-conditioning Unit



Unit Feature

1. Diversified unit forms and functions, can meet all kinds of customization requirements;
2. Great variety of goods and flexible selection, can meet the application requirements of different occasions and environments;
3. First-class accessories, guarantee superior performance, stable quality, safe and reliable operation;
4. Complete control, make the unit always at the optimal operation state;
5. Elegant appearance, easy to install, maintain and repair, reduces the construction period and investment cost.

Unit Model Denotation Method

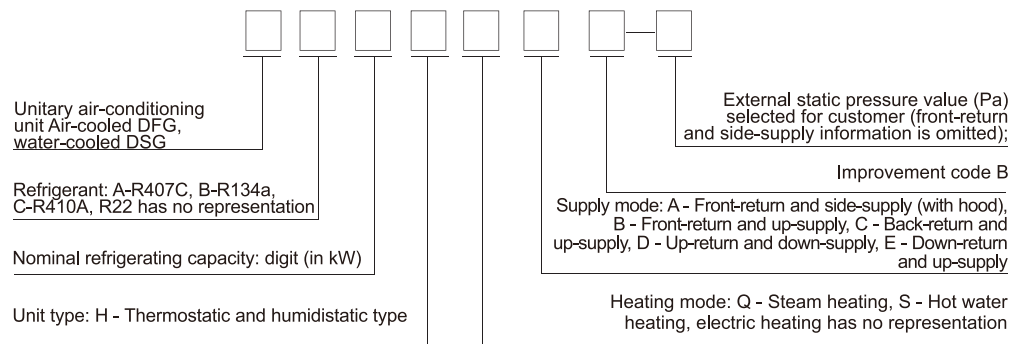

Note: During unit selection, pay attention to the improvement code B; for unit less than 25kW, the unit type shall refer to the technical parameters and shall not comply with above product model interpretation.

Unitary Air-conditioning Unit

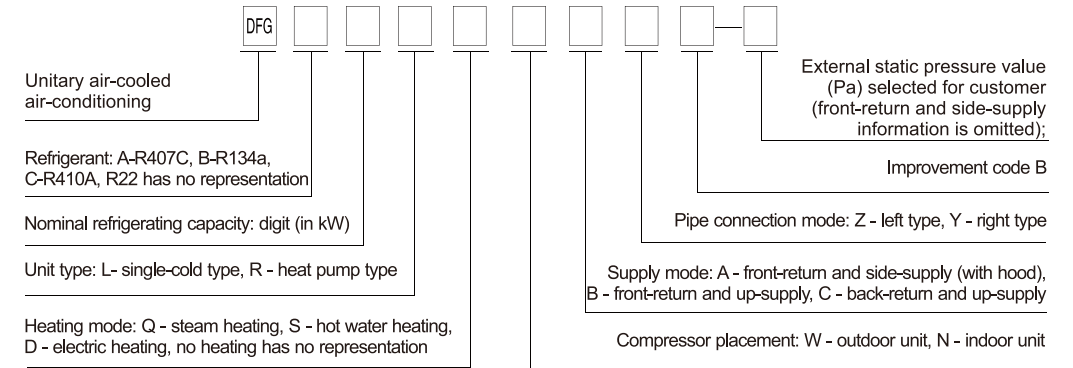

Note: During unit selection, pay attention to the improvement code B; for unit less than 25kW, the unit type shall refer to the technical parameters and shall not comply with above product model interpretation.

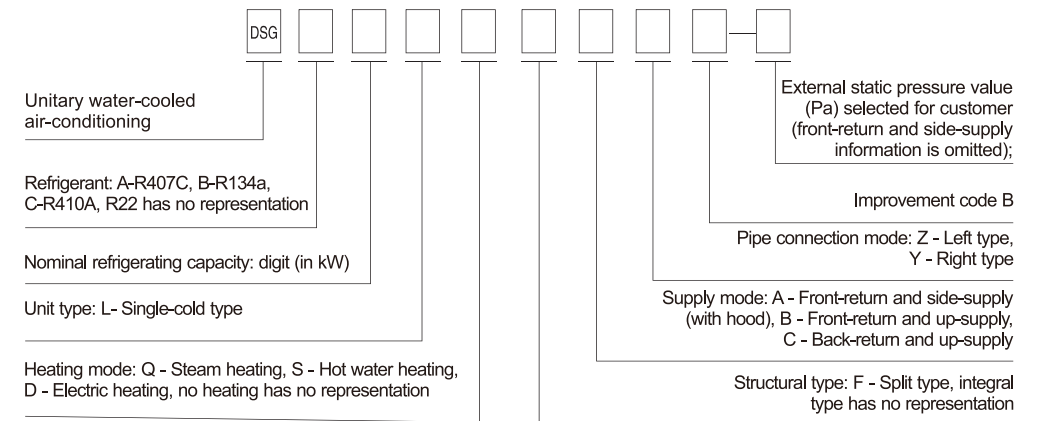

Note: Pay attention to the improvement code B during unit selection

Unitary Air-conditioning Unit

Unit Technical Parameter

Air-cooled Thermostatic and Humidistatic Air-conditioning Unit

Item	Parameter	Type																					
		DF12C(H)-1	DF17C(H)-1	DF22C(H)-1	DFG26H*B	DFG32H*B	DFG38H*B	DFG45H*B	DFG55H*B	DFG68H*B	DFG80H*B	DFG125H*B											
Unit feature	Refrigerating capacity	kW		12.5	18.5	22	26	32	38	45	55	68	80	125									
	Heating capacity (electric heating)	kW		6	9	12	15	18	22	27	33	39	46	68									
	Direct blowing type	m³/h		2700	4100	4900	5600	6600	7700	9700	12000	13600	16000	23000									
	standard	Direct blowing type	Pa		0	0	0	0	0	-	-	-	-	-									
		Duct type	Pa		50	50	75	75	75	100	100	100	100	150	150								
		Max. external static pressure ⁽¹⁾	Pa		150	200	200	200	250	300	300	300	300	300	300								
		Indoor unit noise ⁽³⁾	dB(A)		≤61	≤62	≤63	≤64	≤65	≤66	≤68	≤68	≤70	≤73	≤76								
		Liquid connecting pipe	in		φ 1/2	φ 1/2	φ 1/2×2	φ 1/2×2	φ 1/2×2	φ 5/8	φ 5/8×2	φ 5/8×2	φ 5/8×2	φ 5/8×3	φ 5/8×4								
		Gas connecting pipe	in		φ 5/8	φ 5/8	φ 5/8×2	φ 5/8×2	φ 5/8×2	φ 3/4	φ 3/4×2	φ 3/4×2	φ 3/4×2	φ 1-1/8×3	φ 1-3/8×4								
		Gas connecting pipe (direct blowing type)	in		φ 3/4	φ 3/4	φ 3/4×2	φ 3/4×2	/	/	/	/	/	/	/								
		Filtration efficiency	G3 grade medium & primary efficiency																				
		Temperature control range and precision	18°C ~ 28°C ± 1°C																				
		Temperature control range and precision	50 ~ 70%RH±5%RH - 10%RH																				
		Power supply	3P - 50Hz - 380V																				
		Nominal refrigeration power	kW		4.8	7.2	8.6	10.2	12.1	14.2	17.8	21.5	25.6	30.9	47.7								
Compressor	Type	Hermetic flexible scroll type																					
	Qty	1			2			2			3		4										
	Installation position	Air duct	Indoor unit	Indoor unit	Indoor unit	Indoor unit	Indoor unit	Indoor unit	Indoor unit	Indoor unit	Indoor unit	Indoor unit	Indoor unit	Indoor unit									
		Direct blowing	Outdoor unit	Outdoor unit	Outdoor unit	Outdoor unit	Outdoor unit	/	/	/	/	/	/	/									
Refrigeration	Name of working medium	R22																					
	Charge Qty	4.6		6.5		3.9x2		4.6x2		5.2x2		13		8x2		9.6x2		11.4x2		8.9x3		9.6x4	
	Throttle type	External equalizer thermostatic expansion valve																					
Indoor unit	Fan	Type	Low-noise centrifugal fan																				
		Qty	1		1		1		1		2		2		2		2		2		2		
	Humidification	Type	Electrode type																				
		Humidification Qty	kg/h		4	4	4	4	8	8	8	13	13	13	13								
		Inlet pipe size	φ 1/2"																				
	Heating	Type	Electric heating type																				
		Power	kW		6	9	12	15	18	22	27	33	39	46	68								
	Overall dimension	Duct type	W	mm		1240	1540		1740		2040		2340		2100								
			D	mm		670	670		780		780		780		1250								
			H	mm		1800	1800		1950		1950		1950		1950								
Direct blowing type		W	mm		880	1200		1400		1400		/		/									
		D	mm		470	470		470		600		/		/									
	H	mm		2050	2050		2150		2250		/		/										
	Weight	kg		165	225		280		285		335		/										
Outdoor unit	Type	DW12B		DW17B		DW22B		DWH26C		DWH32C		DWH38C		DWH26C		DWH32C		DWH38C		DWH26C		DWH32C	
	Qty	1		1		1		1		1		2		2		3		4					
	Overall dimension	W	mm		953	720		815		815		845		845		815		845		815		845	
		D	mm		353	720		815		815		845		845		815		845		815		845	
		H	mm		1235	960		1160		1160		1160		1160		1160		1160		1160		1160	
		Weight (duct type)	kg		94	110		125		125		135		135		135		180		200			
		Weight (direct blowing type)	kg		130	150		180		180		200		/		/		/		/		/	

Note: 1. Nominal working condition: Outdoor temperature: DB=35 °C, WB=24 °C; indoor temperature: DB=32 °C, WB=17 °C; external static pressure: 20Pa; connection pipe length of indoor and outdoor unit: 6m; power supply: 80/3/50[V/Ph/Hz];

2. Under rated air volume and G3 filtration efficiency;

3. Noise is tested 2m before and 1m above the unit, with the external static pressure of 20Pa.

Unitary Air-conditioning Unit

Water-cooled Thermostatic and Humidistatic Air-conditioning Unit

Item	Parameter	Type																
		DSG26H*B	DSG30H*B	DSG36H*B	DSG48*B	DSG60*B	DSG70*B	DSG90*B	DSG125*B									
Unit feature	Refrigerating capacity	kW		26	30	36	48	60	70	90	125							
	Heating capacity (electric heating)	kW		15	18	22	27	33	39	50	68							
	Direct blowing type	m³/h		5600	6600	7700	9700	12000	13600	17000	23000							
	standard	Direct blowing type	Pa		0	0	0	-	-	-	-	-						
		Duct type	Pa		75	75	100	100	100	100	150	150						
		Max. external static pressure ⁽¹⁾	Pa		250	250	300	300	300	300	300	300						
		Indoor unit noise ⁽³⁾	dB(A)		≤64	≤65	≤66	≤68	≤68	≤70	≤73	≤76						
		Inlet/outlet water pipe	in		G1-1/2 "	G1-1/2 "	G1-1/2 "	G2 "	G2 "	G2 "	G2-1/2 "	G2-1/2 "						
		Filtration efficiency	G3 grade medium & primary efficiency															
		Temperature control range and precision	18°C ~ 28°C ± 1°C															
		Temperature control range and precision	50 ~ 70%RH±5%RH - 10%RH															
		Power supply	3P - 50Hz - 380V															
		Nominal refrigeration power	kW		8.2	10.2	11.7	14.6	17.9	20.6	26.8	35.8						
	Compressor	Type	Hermetic flexible scroll type															
		Qty	1			2			3		4							
Refrigeration coefficient	Evaporation	Type	Copper tube aluminum fin type															
		Fin type	Hydrophilic shutter type aluminum fin															
	Condenser	Type	Double-tube type or shell and tube type															
		Water flow	m³/h		6.0	7.0	8.3	10.5	13.0	15.2	19.7	28.6						
	Water resistance	kPa		34	35	36	26	33	36	38	39							
Refrigeration	Inlet/outlet water pipe	G1-1/2 "		G1-1/2 "		G1-1/2 "		G2 "		G2 "		G2-1/2 "		G2-1/2 "				
	Name of working medium	R22																
	Charge Qty	6.2		7.5		9		5.6x2		7.5x2		9x2		7.5x3		7.5x4		
	Throttle type	External equalizer thermostatic expansion valve																
Fan	Type	Low-noise centrifugal fan																
	Drive mode	Pulley drive																
Humidifier	Type	Electrode type																
	Humidification Qty	kg/h		4	8	8	8	13	13	15	23							
	Inlet pipe size	φ 1/2"																
Overall dimension	W	mm		1740	1840		2040		2040		2340		2340		2200		2200	
	D	mm		780	780		780		780		780		780		1450		1450	
	H	mm		1950/2250	1950/2250		1950		1950		1950		1950		2100		2100	
	Weight	kg		500	560		620		650		710		760		970		1050	

Note: 1. Nominal working condition: Water inlet temperature:30 °C; water outlet temperature:35 °C; air inlet temperature of indoor side: DB=23 °C, WB= 17 °C; external static pressure: 20Pa; connection pipe length of indoor and outdoor unit: 6m; power supply: 80/3/50[V/Ph/Hz];

2. Under rated air volume and G3 filtration efficiency;

3. Noise is tested 2m before and 1m above the unit, with the external static pressure of 20Pa.

Unitary Air-conditioning Unit

Unit Technical Parameter

Unitary Air-cooled Air-conditioning

Item	Parameter	Type	DF12C	DF17C	DF22C	DF28L(D)	DF35L(D)	DF45L(D)	DF55L(D)	DF65L(D)	DF75L(D)	DF90L(D)	DF110L(D)	DF120L(D)	DF145L(D)	
			(D) / (RD)-1	(D) / (RD)-1	(D) / (RD)-1	(RD) *B	(RD) *B	(RD) *B	(RD) *B	(RD) *B	(RD) *B	(RD) *B	(RD) *B	(RD) *B	(RD) *B	(RD) *B
Air-conditioning unit performance	Refrigerating capacity	kW	12	17.5	22	28	35	45	60	75	90	110	120	145		
	Heating capacity	kW	12.6	18.5	22.5	29.5	36.5	48	65	78	96	115	125	150		
	Heating capacity of hot and cold type/auxiliary electric heating or heat pump	kW	6.5/4.5	9/6	11/6	12/8	15/11	18/14	24/18	30/18	36/28	42/28	48/35	60/35		
	Air volume	m³/h	2200	3000	3500	5200	6300	8000	10500	12500	16500	18500	21000	24000		
	External static pressure	Direct blowing type	Pa	0	0	0	0	0	0	0	0	0	0	0	0	0
		Duct type	Pa	100	100	100	100	120	120	150	150	200	200	250	250	
	Indoor unit noise	dB(A)	≤60	≤62	≤62	≤64	≤64	≤66	≤66	≤68	≤68	≤70	≤70	≤70		
	Temperature control range and sensitivity	18-30°C ± 2°C														
	Pipe connecting direction	Connect pipe on the right or left front														
	Power supply	AC380V/50Hz-3P-N-PE														
	Nominal refrigeration input power	kW	4.7	6.9	8.5	10.8	13.9	17.2	22.8	29.2	33.8	40.9	44.8	54.5		
	Nominal heating input power	kW	4.9	7.2	9.2	11.2	14.5	18.7	23.7	30.3	34.9	41.9	45.8	56.1		
	Compressor	Type	Hermetic scroll type													
		Qty	1	1	1	2	2	2	2	2	3	3	4	4		
	Refrigerant type	R22/R407C/R410A														
Refrigerant charge Qty (kg)		4.4	5.6	6.5	5.2 × 2	6.0 × 2	8.0 × 2	10.5 × 2	11.7 × 2	10.5 × 3	11.7 × 3	10.5 × 4	11.7 × 4			
Indoor unit	Evaporator type		Inner-grooved copper tube cover fin type													
	Compressor	Type	Low-noise centrifugal fan													
		Direct blowing	Drive	Motor direct drive						Pulley drive						
			Power (kW)	0.25	0.37	0.55	0.75	0.75	0.55 × 2	1.1 × 2	1.5 × 2	4.0	4.0	5.5	7.5	
		Duct type	Drive													
		Power (kW)	0.55	1.1	1.5	1.5	2.2	2.2	3.0	3.0	4.0	4.0	5.5	7.5		
	Heater type		Stainless steel tube cover fin type													
	Filter		Primary efficient nylon filter													
	Liquid pipe φ	inch	φ 1/2	φ 1/2	φ 1/2	φ 1/2x2	φ 1/2x2	φ 5/8x2	φ 5/8x2	φ 5/8x2	φ 5/8x3	φ 5/8x3	φ 5/8x4	φ 5/8x4		
	Gas returning pipe φ (with compressor outside)	inch	φ 3/4	φ 3/4	φ 3/4	φ 3/4x2	φ 3/4x2	φ 7/8x2	φ 1-1/8x2	φ 1-3/8x2	φ 1-1/8x3	φ 1-3/8x3	φ 1-1/8x4	φ 1-3/8x4		
	Exhaust pipe φ (with compressor inside)	inch	φ 1/2	φ 1/2	φ 1/2	φ 1/2x2	φ 1/2x2	φ 3/4x2	φ 3/4x2	φ 3/4x2	φ 3/4x3	φ 3/4x3	φ 3/4x4	φ 3/4x4		
	Direct blowing type	L	mm	690	900	900	1250	1470	1620	1700	1700	1980	1980	2200	2200	
		W	mm	520	520	520	550	600	650	800	800	1000	1000	1100	1100	
		H	mm	1895	1895	1895	1895	1945	2075	2175	2175	2385	2380	2605	2605	
	Duct type	H	mm	1895	1895	1895	1895	1945	2075	2175	2175	2000	1995	2210	2210	
Internal compressor weight	kg	185	195	210	275	315	420	485	540	645	735	780	880			
External compressor weight	kg	85	100	110	160	180	240	275	285	325	330	355	365			
Outdoor unit	Type		DW12B	DW17B	DW22B	DW(R)28C	DW(R)35C	DW(R)45C	DW(R)60C	DW(R)75C	DW(R)90C	DW(R)110C	DW(R)60C	DW(R)75C		
	Qty		1	1	1	1	1	1	1	1	1	1	2	2		
	Condenser type		Copper tube cover fin type													
	Condensate fan	Type	Low-noise axial flow fan													
		Power	0.06 × 2	0.55	0.55	0.55	0.55	2 × 0.55	2 × 0.55	2 × 0.55	3 × 0.55	3 × 0.55	2 × 0.55	2 × 0.55		
	Appearance	L	mm	953	720	720	815	845	1880	1880	1940	2900	2990	1880	1940	
		W	mm	353	720	720	815	845	815	815	845	815	845	815	845	
		H	mm	1235	1050	1050	1150	1250	1230	1230	1330	1230	1350	1230	1330	
	Internal compressor weight	kg	90	110	115	125	135	275	280	295	460	465	2*280	2*295		
	External compressor weight	kg	120	150	180	220	250	435	460	545	830	875	2*460	2*545		

Working condition of refrigeration: Outdoor temperature: DB = 35°C, WB = 24°C; indoor temperature: DB = 27°C; WB = 19°C;
Working condition of heating capacity: Outdoor temperature: DB = 7°C WB = 6°C; indoor temperature: DB = 20°C;

Unitary Air-conditioning Unit

Unitary Air-cooled Air-conditioning

Item	Parameter	Type	DSG25L	DSG32L	DSG40L	DSG52L	DSG68L	DSG82L	DSG100L	DSG125L	DSG135L	DSG165L		
			/LD*B	/LD*B	/LD*B	/LD*B	/LD*B	/LD*B	/LD*B	/LD*B	/LD*B	/LD*B	/LD*B	
Unit feature	Refrigerating capacity	kW	25	35	40	52	68	82	100	125	135	165		
	Cold wind electric heating power (optional)	kW	10	12	15	18	24	30	36	42	48	60		
	Refrigerating power	kW	7	9.8	11.3	15.5	21.2	24.2	31.8	36.4	40.9	46.9		
	Circulating air volume	m³/h	3500	5200	6300	8200	10500	12500	16500	18500	21000	24500		
	External static pressure	Direct blowing type	Pa	0	0	0	0	0	0	0	0	0	0	
		Duct type	Pa	100	100	120	120	150	150	200	200	250	250	
	Refrigerant	R22/R410A												
	Pipe connecting direction	Connect pipe on the right or left front												
	Cooling water pipe size	inch	G1"	G1-1/2"				G2"			G2-1/2"			
	Power supply	AC380V/50Hz-3P-N-PE												
	Unit noise	dB(A)	≤62	≤64	≤66	≤66	≤68	≤68	≤70	≤70	≤71	≤71		
	Direct blowing type	L	mm	900	1250	1470	1620	1700	1700	1980	1980	2200	2200	
		W	mm	520	550	600	650	800	800	1000	1000	1100	1100	
		H	mm	1895	1895	1945	2075	2175	2175	2385	2380	2605	2605	
	Parameter	H	mm	1895	1895	1945	2075	2175	2175	2000	1995	2210	2210	
Unit weight	kg	245	290	320	425	515	535	920	1000	1150	1250			
Refrigerating system feature	Compressor		Hermetic scroll type											
	Type													
	Qty	1	2	2	2	2	2	3	3	4	4			
	Power supply	3P-50Hz-380V												
	Refrigerant	Charge Qty kg	4.4	3.3 × 2	3.8 × 2	5.0 × 2	6.6 × 2	7.7 × 2	7.0 × 3	7.7 × 3	7.0 × 4	7.7 × 4		
	Condenser	Type	Flooded efficient tank					Shell and tube type						
		Water flow	m³/h	5.8	8	9.2	12.6	16	18.4	24.1	27.5	31	35.6	
		Water resistance	kPa	28	24	30	34	36	38	42	42	44	44	
	Evaporator	Type	Copper tube cover fin type											
		Fin form	Shutter type hydrophilic film aluminum fin											
	Throttle type	External equalizer thermostatic expansion valve												
	Blower	Type	Low-noise centrifugal fan											
		Direct blowing type	Drive mode	Motor direct drive						Pulley drive				
			Power (kW)	0.55	0.75	0.75	0.55 × 2	1.1 × 2	1.5 × 2	4.0	4.0	5.5	7.5	
		Parameter	Drive mode	Pulley drive										
	Power (kW)	1.5	1.5	2.2	2.2	3.0	3.0	4.0	4.0	5.5	7.5			
Electric heater type	Stainless steel tube cover fin type													
Air filter	Primary efficient nylon filter													
Outlet pipe size	inch	G3/4"					G1"							

Note: 1. Test condition of refrigeration: Return air temperature: DB = 27 °C, WB = 19 °C, water inlet temperature: 30 °C, water outlet temperature: 35 °C.

2. The refrigeration input power in the table doesn't include the input power of cooling tower and water pump.

3. The specifications in the table may be changed without further notice.

4. The refrigeration charge quantity in the table is only for R22, and the charge quantity of other refrigerants shall refer to the specific data in the manual provided with the unit.

Unitary Air-conditioning Unit



Unit Feature

1. Great variety of goods and flexible selection, can meet the application requirements of different occasions and environments;
2. First-class accessories, guarantee superior performance, stable quality, safe and reliable operation;
3. Complete control, make the unit always at the optimal operation state;
4. Direct efficient centrifugal fan, reduce belt maintenance and repair as well as fault;
5. Elegant appearance, easy to install, maintain and repair, reduces the construction period and investment cost.

Unit Model Denotation Method

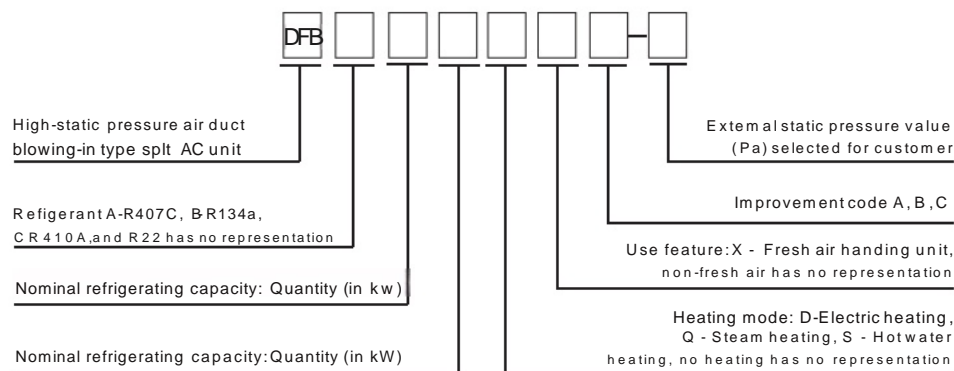

Example: 1. DFB28F1Dx-150 indicates a heat pump all fresh air unit with auxiliary electric heating, with the refrigerating capacity of 28kW, external static pressure of 150Pa and refrigerant of R22.

2. If a unit of cold and hot type with the nominal refrigerating capacity of 45kW, refrigerant of R407C, and external static pressure of 250Pa, the type shall be DFBA45LD-250.

Unitary Air-conditioning Unit

Unit Technical Parameter Table

High-static pressure air duct blowing-in type split AC unit- Return air type/R22 refrigerant [single cold type/cold and hot type/DFB**L/D]

Parameter	Type	DF12C(D)	DF17C(D)	DF22C(D)	DFB28LD	DFB32LD	DFB45LD	DFB60LD	DFB70LD	DFB90LD	DFB100LD
Refrigerating capacity	kW	12	17	22	28	32.5	44.5	59	69.5	89	100.5
	10kcal/h	103	1.46	1.89	2.37	2.75	3.83	5.07	5.98	7.65	8.64
	%	100.0	100.0	100.50.0	100.50.0	100.50.0	100.50.0	100.50.0	100.50.0	100.66.33.0	100.66.33.0
H	kW	4.5	6	8	9	9	12	12	18	18	24
	10kcal/h	0.39	0.52	0.69	0.77	0.77	1.03	1.03	1.55	1.55	2.06
Air volume	m³/h	2400	3200	4600	5000	6000	8000	11000	13500	16000	18000
External static pressure	Pa	60/100/150	60/100/150	60/150/200	80/150/250	80/150/250	120/200/250	150/250/350	150/250/350	150/250/400	150/250/400
	Unit noise	dB(A)	60/62/63	66/67/69	66/68/69	64/65/68	65/66/69	65/66/70	66/68/73	72/75/78	72/76/80
Temperature control range		Temperature control range of 18~30°C, and sensitivity of ±0.2°C									
Power supply		3/N/PE AC380V/220V 50Hz									
Compressor	Type	Hermetic scroll compressor									
	Working medium	R22									
Refrigerant	Control form	External equalizer thermostatic expansion valve									
	Charge Qty(kg)	4.6	5.8	2x4.2	2x3.5	2x4	2x6	2x7	2x8	3x7	3x8
Evaporator type		Efficient red copper tube cover aluminum fin									
Fan	Type	Efficient centrifuge									
	Quantity	1	1 or 2	2	2	2	2	2	2	2	2
Heater	Type	Electric type (level 2)									
	Power	4.5	6	8	9	9	12	12	18	18	24
Condensate drain		DN20									
Filter		Black double-layer nylon filter screen									
Comes in pipe		Threaded connection					Welding				
	Liquid pipe (mm)	12	12	2x12	2x12	2x16	2x16	2x16	3x16		
Ar pipe (mm)	19	19	2x19	2x19	2x22	2x28	3x28				
Weight	L(mm)	1180	1180	1480	1700	1700	2150	2350			
	W(mm)	720	720	820	760	820	1100	1200			
	H(mm)	450	450	550	520	690	830	1010			
Type		DW12B	DW17B	DW22B	DW28SB	DW32SB	DW20B	DW28B	DW32B	DW28B	DW32B
	Quantity	1	1	1	1	1	2	2	2	3	3
Condenser type		Efficient red copper tube cover aluminum fin									
Fan	Type	High-efficient axial low fan									
	Quantity	2	1	1	2	2	2	2	2	3	3
Weight	L(mm)	953	720	815	1592		1050				
	W(mm)	358	720	815	974		940				
	H(mm)	1235	1060	1160	1155		1160				
Weight	kg	135	150	210	210	220	2x140	2x160	2x170	3x160	3x170

Note: Declared working condition of refrigerating capacity. Air inlet dry bulb temperature of indoor unit is 27°C, and wet bulb temperature is 19°C; and air inlet dry bulb temperature of outdoor unit is 35°C.

- o The cold and hot type is equipped with electric heating, refer to above table for the electric heating power, while the single cold type doesn't have;
- o The weight of indoor unit equals to that of cold and hot type unit with high-end static pressure;
- o The power supply voltage fluctuation is within ±10% and the three-phase power supply imbalance is within 2%;
- o The user shall not change the refrigerant type without permission;
- o The product design may be changed without further notice, please subject to the unit nameplate.

High-static Pressure Air Duct Blowing-in Type Split AC Unit

High-static pressure air duct blowing-in type split AC unit - All fresh air type/R22 refrigerant [single cold type/cold and hot type/DFB** L/DX]

Parameter		Type	DF12C(R/D)	DF17C(R/D)	DF22C(R/D)	DFB28R/D	DFB32R/D	DFB45R/D	DFB60R/D	DFB70R/D	DFB90R/D	DFB100R/D
Air-conditioning unit performance	Refrigerating capacity	kW	12	17	22	28	32.5	44.5	59	69.5	89	100.5
		10 ⁴ kcal/h	1.03	1.46	1.89	2.37	2.75	3.83	5.07	5.98	7.65	8.64
	Heating capacity	kW	12.5	17.5	23	28.5	34.1	47.5	62.5	73.5	93.5	105
		10 ⁴ kcal/h	1.07	1.50	1.98	2.45	2.93	4.09	5.38	6.32	8.04	9.03
	Energy regulation	%	100.0	100.0	100.50.0	100.50.0	100.50.0	100.50.0	100.50.0	100.50.0	100.66.33.0	100.66.33.0
	Heating capacity	kW	4.5	6	8	9	9	12	12	18	18	24
		10 ⁴ kcal/h	0.39	0.52	0.69	0.77	0.77	1.03	1.03	1.55	1.55	2.06
	Air volume	m ³ /h	2400	3200	4600	5000	6000	8000	11000	13500	16000	18000
	External static pressure	Pa	60/100/150	60/100/150	100/150/200	80/150/250	80/150/250	120/200/250	150/250/350	150/250/350	150/250/400	150/250/400
	Unit noise	dB(A)	60/62/63	66/67/69	66/68/69	65/66/68	65/66/69	65/66/70	66/68/73	72/75/78	72/76/80	73/77/80
Temperature control range and sensitivity		Temperature control range of 18-30°C, and sensitivity of ±2°C										
Power supply		3/N/PE AC 380V/220V 50Hz										
Refrigeration input power under normal working condition	kW	4.7	6.8	8.8	10.5	12.2	16.5	22.3	26.5	33.5	37.5	
	10 ⁴ kcal/h	4.9	6.9	9	10.5	12.5	17	23.2	27.4	35.2	39.6	
Compressor	Type	Hermetic scroll compressor										
	Working medium used	R22										
Refrigerant	Control form	External equalizer thermostatic expansion valve										
	Charge Qty (kg)	4.6	5.8	2 × 4.2	2 × 3.5	2 × 4	2 × 6	2 × 7	2 × 8	3 × 7	3 × 8	
Evaporator type		Efficient red copper tube cover aluminum fin										
Fan	Type	Efficient centrifuge										
	Qty	1	1 or 2	2	2	2	2	2	2	2	2	
Heater	Type	Electric type (level 2)										
	Power	4.5	6	8	9	9	12	12	18	18	24	
Condensate drain		DN20										
Filter		Black double-layer nylon filter screen										
Connecting pipe	Connection type	Threaded connection					Welding					
	Liquid pipe φ (mm)	φ12	φ12	2 × φ12	2 × φ12	2 × φ16	2 × φ16	3 × φ16				
	Air pipe φ (mm)	φ19	φ19	2 × φ19	2 × φ19	2 × φ22	2 × φ28	3 × φ28				
Appearance	L (mm)	1180	1180	1480	1700	1700	2150	2350				
	W (mm)	720	720	820	760	820	1100	1200				
	H (mm)	450	450	550	520	690	830	1010				
	Weight	kg	80	100	150	140	150	180	320	350	420	450
Type		DW12B	DW17B	DW22B	DWR28SB	DWR32SB	DWR20B	DWR28B	DWR32B	DWR28B	DWR32B	
Qty		1	1	1	1	1	2	2	2	3	3	
Condenser type		Efficient red copper tube cover aluminum fin										
Condensate fan	Type	High-efficient axial flow fan										
	Qty	2	1	1	2	2	2	2	2	3	3	
Appearance	L (mm)	953	720	815	1592			1050				
	W (mm)	353	720	815	974			940				
	H (mm)	1235	1060	1160	1155			1160				
	Weight	kg	135	150	210	210	220	2 × 140	2 × 160	2 × 170	3 × 160	3 × 170

- Note:**
- Declared working condition of refrigerating capacity: Air inlet dry bulb temperature of indoor unit is 27 °C, and wet bulb temperature is 19 °C; and air inlet dry bulb temperature of outdoor unit is 35 °C;
 - Declared working condition of heating capacity: Air inlet dry bulb temperature of indoor unit is 20 °C; air inlet dry bulb temperature of outdoor unit is 7 °C, and wet bulb temperature is 6 °C;
 - The standard configuration of heat pump unit is equipped with auxiliary electric heating; if you don't need such function, please specify at the time of ordering;
 - The weight of indoor unit equals to that of high-end static pressure unit;
 - The power supply voltage fluctuation is within ±10% and the three-phase power supply imbalance is within 2%;
 - The user shall not change the refrigerant type without permission;
 - The product design may be changed without further notice, please subject to the unit nameplate.

High-static Pressure Air Duct Blowing-in Type Split AC Unit

High-static pressure air duct blowing-in type split AC unit - All fresh air type/R22 refrigerant [single cold type/cold and hot type/DFB** L/DX]

Parameter		Type	DF12C(DX)	DF17C(DX)	DF22C(DX)	DFB28L/DX	DFB32L/DX	DFB45L/DX	DFB60L/DX	DFB70L/DX	DFB90L/DX	DFB100L/DX	
Air-conditioning unit performance	Refrigerating capacity	kW	12	17	22	28	32.5	44.5	59	69.5	89	100.5	
		10 ⁴ kcal/h	1.03	1.46	1.89	2.37	2.75	3.83	5.07	5.98	7.65	8.64	
	Energy regulation	%	100.0	100.0	100.50.0	100.50.0	100.50.0	100.50.0	100.50.0	100.50.0	100.50.0	100.66.33.0	100.66.33.0
		Heating capacity	kW	4.5	6	8	9	9	12	12	18	18	24
	Air volume	m ³ /h	1000	1400	1800	2500	3000	4000	5000	6000	8000	9000	
		External static pressure	Pa	60/100/150	60/100/150	100/150/200	80/150/250	80/150/250	80/150/250	80/150/250	80/150/250	120/200/300	150/250/400
	Unit noise	dB(A)	60/62/63	66/67/69	66/68/69	64/65/67	64/65/67	65/66/69	65/66/70	65/68/70	66/68/72	70/73/75	
	Power supply		3/N/PE AC 380V/220V 50Hz										
	Refrigeration input power under normal working condition	kW	4.7	6.8	8.8	10.5	12.2	16.5	22.3	26.5	33.5	37.5	
	Compressor	Type	Hermetic scroll compressor										
Working medium used		R22											
Refrigerant	Control form	External equalizer thermostatic expansion valve											
	Charge Qty (kg)	4.6	5.8	2 × 4.2	2 × 3.5	2 × 4	2 × 6	2 × 7	2 × 8	3 × 7	3 × 8		
Evaporator type		Efficient red copper tube cover aluminum fin											
Fan	Type	Efficient centrifuge											
	Qty	1	1	1	1	1	2	2	2	2	2		
Heater	Type	Electric type (level 2)											
	Power	4.5	6	8	9	9	12	12	18	18	24		
Condensate drain		DN20											
Filter		Black double-layer nylon filter screen											
Connecting pipe	Connection type	Threaded connection					Welding						
	Liquid pipe φ (mm)	φ12	φ12	2 × φ12	2 × φ12	2 × φ16	2 × φ16	2 × φ16		3 × φ16			
	Air pipe φ (mm)	φ19	φ19	2 × φ19	2 × φ19	2 × φ22	2 × φ28	2 × φ28		3 × φ28			
Appearance	L (mm)	1180	1180	1480	1700	1700	2150	1700				1700	
	W (mm)	720	720	820	760	820	1100	760				820	
	H (mm)	450	450	550	520	690	830	520				690	
	Weight	kg	80	100	150	140	150	180	320	350	420	450	
Type		DW12B	DW17B	DW22B	DW28SB	DW32SB	DW20B	DW28B	DW32B	DW28B	DW32B		
Qty		1	1	1	1	1	2	2	2	3	3		
Condenser type		Efficient red copper tube cover aluminum fin											
Condensate fan	Type	High-efficient axial flow fan											
	Qty	2	1	1	2	2	2	2	2	3	3		
Appearance	L (mm)	953	720	815	1592			1050					
	W (mm)	353	720	815	974			940					
	H (mm)	1235	1060	1160	1155			1160					
	Weight	kg	135	150	210	210	220	2 × 140	2 × 160	2 × 170	3 × 160	3 × 170	

- Note:**
- Declared working condition of refrigerating capacity: Air inlet dry bulb temperature of indoor unit is 35 °C, and wet bulb temperature is 28 °C;
 - The cold and hot type is equipped with electric heating, refer to above table for the electric heating power; while the single cold type doesn't have;
 - The weight of indoor unit equals to that of cold and hot type unit with high-end static pressure;
 - The power supply voltage fluctuation is within ±10% and the three-phase power supply imbalance is within 2%;
 - The user shall not change the refrigerant type without permission;
 - The product design may be changed without further notice.

High-static Pressure Air Duct Blowing-in Type Split AC Unit

High-static pressure air duct blowing-in type split AC unit - All fresh air type/R22 refrigerant [heat pump type/DFB** R/DX]

Parameter	Type	Type									
		DF12C(R/DX)	DF17C(R/DX)	DF22C(R/DX)	DFB28R/DX	DFB32R/DX	DFB45R/DX	DFB60R/DX	DFB70R/DX	DFB90R/DX	DFB100R/DX
Refrigerating capacity	kW	12	17	22	28	32.5	44.5	59	69.5	89	100.5
	10 ⁴ kcal/h	1.03	1.46	1.89	2.37	2.75	3.83	5.07	5.98	7.65	8.64
Heating capacity	kW	12.5	17.5	23	28.5	34.1	47.5	62.5	73.5	93.5	105
	10 ⁴ kcal/h	1.07	1.50	1.98	2.45	2.93	4.09	5.38	6.32	8.04	9.03
Energy regulation	%	100.0	100.0	100.50.0	100.50.0	100.50.0	100.50.0	100.50.0	100.50.0	100.66.33.0	100.66.33.0
Heating capacity	kW	4.5	6	8	9	9	12	12	18	18	24
	10 ⁴ kcal/h	0.39	0.52	0.69	0.77	0.77	1.03	1.03	1.55	1.55	2.06
Air volume	m ³ /h	1000	1400	1800	2500	3000	4000	5000	6000	8000	9000
External static pressure	Pa	60/100/150	60/100/150	100/150/200	80/150/250	80/150/250	80/150/250	80/150/250	80/150/250	120/200/300	150/250/400
Unit noise	dB(A)	60/62/63	66/67/69	66/68/69	64/65/67	64/65/67	65/66/69	65/66/70	65/68/70	66/68/72	70/73/75
Power supply		3/N/PE AC 380V/220V 50Hz									
Refrigerant input power under normal working condition	kW	4.7	6.8	8.8	10.5	12.2	16.5	22.3	26.5	33.5	37.5
	10 ⁴ kcal/h	4.9	6.9	9	6.25	7.15	9.58	12.78	14.35	18.75	20.84
Heating input power under normal working condition	kW	4.9	6.9	9	6.25	7.15	9.58	12.78	14.35	18.75	20.84
	10 ⁴ kcal/h	4.9	6.9	9	6.25	7.15	9.58	12.78	14.35	18.75	20.84
Compressor	Type	Hermetic scroll compressor									
Refrigerant	Working medium used	R22									
	Control form	External equalizer thermostatic expansion valve									
Compressor	Charge Qty (kg)	4.6	5.8	2×4.2	2×3.5	2×4	2×6	2×7	2×8	3×7	3×8
	Control form	External equalizer thermostatic expansion valve									
Evaporator type	Efficient red copper tube cover aluminum fin										
Fan	Type	Efficient centrifuge									
	Qty	1	1	1	1	1	2	2	2	2	2
Heater	Type	Electric type (level 2)									
	Power	4.5	6	8	9	9	12	12	18	18	24
Condensate drain	DN20										
Filter	Black double-layer nylon filter screen										
Connecting pipe	Connection type	Threaded connection					Welding				
	Liquid pipe φ (mm)	φ12	φ12	2×φ12	2×φ12	2×φ16	2×φ16	3×φ16			
Appearance	Air pipe φ (mm)	φ19	φ19	2×φ19	2×φ19	2×φ22	2×φ28	3×φ28			
	L (mm)	1180	1180	1480	1200	1700	1700				
Weight	W (mm)	720	720	820	760	760	820				
	H (mm)	450	450	550	520	520	690				
Type	DW12B DW17B DW22B DWR28SB DWR32SB DWR20B DWR28B DWR32B DWR28B DWR32B										
Qty	1 1 1 1 1 2 2 2 3 3										
Condenser type	Efficient red copper tube cover aluminum fin										
Condensate fan	Type	High-efficient axial flow fan									
	Qty	2	1	1	2	2	2	2	2	3	3
Appearance	L (mm)	953	720	815	1592	1050					
	W (mm)	353	720	815	974	940					
Weight	H (mm)	1235	1060	1160	1155	1160					
	kg	135	150	210	210	220	2×140	2×160	2×170	3×160	3×170

- Note:**
- Declared working condition of refrigerating capacity: Air inlet dry bulb temperature of indoor unit is 35 °C, and wet bulb is 28 °C;
 - Air inlet dry bulb temperature of outdoor unit is 7 °C, and wet bulb temperature is 6 °C;
 - The standard configuration of heat pump unit is equipped with auxiliary electric heating; if you don't need such function, please specify at the time of ordering; if the outdoor temperature is low, it is recommended to use electric heating to preheat the fresh air when starting heating; the weight of indoor unit equals to that of high-end static pressure unit;
 - The power supply voltage fluctuation is within ±10% and the three-phase power supply imbalance is within 2%;
 - The user shall not change the refrigerant type without permission;
 - The product design may be changed without further notice, please subject to the unit nameplate.

High-static Pressure Air Duct Blowing-in Type Split AC Unit

High-static pressure air duct blowing-in type split AC unit - Return air type/R407C refrigerant [single cold type/cold and hot type/DFBA**LD]

Parameter	Type	Type									
		DF12C(AD)	DF17C(AD)	DF22C(AD)	DFBA28L/D	DFBA32L/D	DFBA45L/D	DFBA60L/D	DFBA70L/D	DFBA90L/D	DFBA100L/D
Refrigerating capacity	kW	11.4	16.2	20.9	26	30	42	56	66	84.5	95
	10 ⁴ kcal/h	0.98	1.39	1.80	2.24	2.58	3.61	4.82	5.68	7.27	8.17
Energy regulation	%	100.0	100.0	100.50.0	100.50.0	100.50.0	100.50.0	100.50.0	100.50.0	100.66.33.0	100.66.33.0
Heating capacity	kW	4.5	6	8	9	9	12	12	18	18	24
	10 ⁴ kcal/h	0.39	0.52	0.69	0.77	0.77	1.03	1.03	1.55	1.55	2.06
Air volume	m ³ /h	2400	3200	4600	5000	6000	8000	11000	13500	16000	18000
External static pressure	Pa	60/100/150	60/100/150	100/150/200	80/150/250	80/150/250	120/200/250	150/250/350	150/250/350	150/250/400	150/250/400
Unit noise	dB(A)	60/62/63	66/67/69	66/68/69	64/65/68	65/66/69	65/66/70	66/68/73	72/75/78	72/76/80	73/77/80
Temperature control range and sensitivity		Temperature control range of 18-30°C, and sensitivity of ±2°C									
Power supply		3/N/PE AC 380V/220V 50Hz									
Refrigerant input power under normal working condition	kW	4.7	6.8	8.8	10.3	11.8	16.2	21.5	25.8	32.5	36.4
	10 ⁴ kcal/h	4.9	6.9	9	6.25	7.15	9.58	12.78	14.35	18.75	20.84
Compressor	Type	Hermetic scroll compressor									
Refrigerant	Working medium used	R407C									
	Control form	External equalizer thermostatic expansion valve									
Compressor	Charge Qty (kg)	4.6	5.8	2×4.2	2×3.5	2×4	2×6	2×7	2×8	3×7	3×8
	Control form	External equalizer thermostatic expansion valve									
Evaporator type	Efficient red copper tube cover aluminum fin										
Fan	Type	Efficient centrifugal fan									
	Qty	1	1	1	2	2	2	2	2	2	2
Heater	Type	Electric type (level 2)									
	Power	4.5	6	8	9	9	12	12	18	18	24
Condensate drain	DN20										
Filter	Black double-layer nylon filter screen										
Connecting pipe	Connection type	Threaded connection					Welding				
	Liquid pipe φ (mm)	φ12	φ12	2×φ12	2×φ12	2×φ16	2×φ16	3×φ16			
Appearance	Air pipe φ (mm)	φ19	φ19	2×φ19	2×φ19	2×φ22	2×φ28	3×φ28			
	L (mm)	1180	1180	1480	1700	1700	2150	2350			
Weight	W (mm)	720	720	820	760	760	820	1100	1200		
	H (mm)	450	450	550	520	520	690	830	1010		
Type	DW12B DW17B DW22B DWA28SB DWA32SB DWA20B DWA28B DWA32B DWA28B DWA32B										
Qty	1 1 1 1 1 2 2 2 3 3										
Condenser type	Efficient red copper tube cover aluminum fin										
Condensate fan	Type	High-efficient axial flow fan									
	Qty	2	1	1	2	2	2	2	2	3	3
Appearance	L (mm)	953	720	815	1592	1050					
	W (mm)	353	720	815	974	940					
Weight	H (mm)	1235	1060	1160	1155	1160					
	kg	135	150	210	210	220	2×140	2×160	2×170	3×160	3×170

- Note:**
- Declared working condition of refrigerating capacity: Air inlet dry bulb temperature of indoor unit is 27 °C, and wet bulb temperature is 19 °C; and air inlet dry bulb temperature of outdoor unit is 35 °C;
 - The cold and hot type is equipped with electric heating, refer to above table for the electric heating power; while the single cold type doesn't have;
 - The weight of indoor unit equals to that of cold and hot type unit with high-end static pressure;
 - The power supply voltage fluctuation is within ±10% and the three-phase power supply imbalance is within 2%;
 - The user shall not change the refrigerant type without permission;
 - The product design may be changed without further notice, please subject to the unit nameplate.

High-static Pressure Air Duct Blowing-in Type Split AC Unit

High-static pressure air duct blowing-in type split AC unit - Return air type/R407C refrigerant [heat pump type/DFB** R/D]

Parameter		Type	DF12C(AR/D)	DF17C(AR/D)	DF22C(AR/D)	DFBA28R/D	DFBA32R/D	DFBA45R/D	DFBA60R/D	DFBA70R/D	DFBA90R/D	DFBA100R/D	
Air-conditioning unit performance	Refrigerating capacity	kW	11.4	16.2	20.9	26	30	42	56	66	84.5	95	
		10 ⁴ kcal/h	0.98	1.39	1.80	2.24	2.58	3.61	4.82	5.68	7.27	8.17	
	Heating capacity	kW	11.88	16.6	21.9	27	32.4	45	60	70	88.5	99.5	
		10 ⁴ kcal/h	1.02	1.43	1.88	2.32	2.79	3.87	5.16	6.02	7.61	8.56	
	Energy regulation	%	100.0	100.0	100.50.0	100.50.0	100.50.0	100.50.0	100.50.0	100.50.0	100.66.33.0	100.66.33.0	
	Heating capacity	kW	4.5	6	8	9	9	12	12	18	18	24	
		10 ⁴ kcal/h	0.39	0.52	0.69	0.77	0.77	1.03	1.03	1.55	1.55	2.06	
	Air volume	m ³ /h	2400	3200	4600	5000	6000	8000	11000	13500	16000	18000	
	External static pressure	Pa	60/100/150	60/100/150	100/150/200	80/150/250	80/150/250	120/200/250	150/250/350	150/250/350	150/250/400	150/250/400	
	Unit noise	dB(A)	60/62/63	66/67/69	66/68/69	65/66/68	65/66/69	65/66/70	66/68/73	72/76/80	73/77/80		
	Temperature control range and sensitivity	Temperature control range of 18-30°C, and sensitivity of ±2°C											
	Power supply	3/N/PE AC 380V/220V 50Hz											
Refrigerant input power under nominal working condition	kW	4.7	6.8	8.8	10.3	11.8	16.2	21.5	25.8	32.5	36.4		
	10 ⁴ kcal/h	4.0	5.8	7.5	8.8	10.2	14.2	18.5	23.2	28.2	31.2		
Heating input power under nominal working condition	kW	4.9	6.9	9	10.4	12.3	16.6	22.7	26.8	34.5	38.8		
	10 ⁴ kcal/h	4.2	6.0	7.7	8.8	10.5	14.2	18.8	23.8	29.8	33.2		
Compressor	Type	Hermetic scroll compressor											
Refrigerant	Working medium used	R407C											
	Control form	External equalizer thermostatic expansion valve											
Refrigerant	Charge Qty (kg)	4.6	5.8	2 × 4.2	2 × 3.5	2 × 4	2 × 6	2 × 7	2 × 8	3 × 7	3 × 8		
	Evaporator type	Efficient red copper tube cover aluminum fin											
Fan	Type	Efficient centrifugal fan											
	Qty	1	1	1	2	2	2	2	2	2	2		
Heater	Type	Electric type (level 2)											
	Power	4.5	6	8	9	9	12	12	18	18	24		
Condensate drain	DN20												
Filter	Black double-layer nylon filter screen												
Connecting pipe	Connection type	Threaded connection						Welding					
	Liquid pipe φ (mm)	φ12	φ12	2 × φ12	2 × φ12	2 × φ16	2 × φ16	3 × φ16					
	Air pipe φ (mm)	φ19	φ19	2 × φ19	2 × φ19	2 × φ22	2 × φ28	3 × φ28					
Appearance	L (mm)	1180	1180	1480	1700	1700	2150	2350					
	W (mm)	720	720	820	760	820	1100	1200					
	H (mm)	450	450	550	520	690	830	1010					
	Weight	kg	80	100	150	140	150	180	320	350	420	450	
Outdoor unit	Type	DW12B	DW17B	DW22B	DWRA28SB	DWRA32SB	DWRA20B	DWRA28B	DWRA32B	DWRA28B	DWRA32B		
	Qty	1	1	1	1	1	2	2	2	3	3		
Condenser type	Efficient red copper tube cover aluminum fin												
	Type	High-efficient axial flow fan											
Condensate fan	Qty	2	1	1	2	2	2	2	2	3	3		
	L (mm)	953	720	815	1592			1050					
Appearance	W (mm)	353	720	815	974			940					
	H (mm)	1235	1060	1160	1155			1160					
	Weight	kg	135	150	210	210	220	2 × 140	2 × 160	2 × 170	3 × 160	3 × 170	

- Note:
- Declared working condition of refrigerating capacity: Air inlet dry bulb temperature of indoor unit is 27 °C, and wet bulb temperature is 19 °C; and air inlet dry bulb temperature of outdoor unit is 35 °C;
 - Declared working condition of heating capacity: Air inlet dry bulb temperature of indoor unit is 20 °C; air inlet dry bulb temperature of outdoor unit is 7 °C, and wet bulb temperature is 6 °C;
 - The standard configuration of heat pump unit is equipped with auxiliary electric heating; if you don't need such function, please specify at the time of ordering;
 - The weight of indoor unit equals to that of high-end static pressure unit;
 - The power supply voltage fluctuation is within ±10% and the three-phase power supply imbalance is within 2%;
 - The user shall not change the refrigerant type without permission;
 - The product design may be changed without further notice, please subject to the unit nameplate.

High-static Pressure Air Duct Blowing-in Type Split AC Unit

High-static pressure air duct blowing-in type split AC unit - All fresh air type/R407C refrigerant [single cold type/cold and hot type/DFBA**L/Dx]

Parameter		Type	DF12C(ADX)	DF17C(ADX)	DF22C(ADX)	DFBA28L/DX	DFBA32L/DX	DFBA45L/DX	DFBA60L/DX	DFBA70L/DX	DFBA90L/DX	DFBA100L/DX	
Refrigerating capacity	kW	11.4	16.2	20.9	26	30	42	56	66	84.5	95		
	10 ⁴ kcal/h	0.98	1.39	1.80	2.24	2.58	3.61	4.82	5.68	7.27	8.17		
Energy regulation	%	100.0	100.0	100.50.0	100.50.0	100.50.0	100.50.0	100.50.0	100.50.0	100.66.33.0	100.66.33.0		
Heating capacity	kW	4.5	6	8	9	9	12	12	18	18	24		
	10 ⁴ kcal/h	0.39	0.52	0.69	0.77	0.77	1.03	1.03	1.55	1.55	2.06		
Air volume	m ³ /h	1000	1400	1800	2500	3000	4000	5000	6000	8000	9000		
External static pressure	Pa	60/100/150	60/100/150	100/150/200	80/150/250	80/150/250	80/150/250	80/150/250	80/150/250	120/200/300	150/250/400		
Unit noise	dB(A)	60/62/63	66/67/69	66/68/69	64/65/67	64/65/67	65/66/69	65/66/70	65/68/70	66/68/72	70/73/75		
Power supply	3/N/PE AC 380V/220V 50Hz												
Refrigerant input power under nominal working condition	kW	4.7	6.8	8.8	10.3	11.8	16.2	21.5	25.8	32.5	36.4		
Compressor	Type	Hermetic scroll compressor											
Refrigerant	Working medium used	R407C											
	Control form	External equalizer thermostatic expansion valve											
Refrigerant	Charge Qty (kg)	4.6	5.8	2 × 4.2	2 × 3.5	2 × 4	2 × 6	2 × 7	2 × 8	3 × 7	3 × 8		
	Evaporator type	Efficient red copper tube cover aluminum fin											
Fan	Type	Efficient centrifugal fan											
	Qty	1	1	1	1	1	2	2	2	2	2		
Heater	Type	Electric type (level 2)											
	Power	4.5	6	8	9	9	12	12	18	18	24		
Condensate drain	DN20												
Filter	Black double-layer nylon filter screen												
Connecting pipe	Connection type	Threaded connection						Welding					
	Liquid pipe φ (mm)	φ12	φ12	2 × φ12	2 × φ12	2 × φ16	2 × φ16	3 × φ16					
	Air pipe φ (mm)	φ19	φ19	2 × φ19	2 × φ19	2 × φ22	2 × φ28	3 × φ28					
Appearance	L (mm)	1180	1180	1480	1700	1700	2150	2350					
	W (mm)	720	720	820	760	820	1100	1200					
	H (mm)	450	450	550	520	690	830	1010					
	Weight	kg	80	100	150	140	150	180	320	350	420	450	
Outdoor unit	Type	DW12B	DW17B	DW22B	DWA28SB	DWA32SB	DWA20B	DWA28B	DWA32B	DWA28B	DWA32B		
	Qty	1	1	1	1	1	2	2	2	3	3		
Condenser type	Efficient red copper tube cover aluminum fin												
	Type	High-efficient axial flow fan											
Condensate fan	Qty	2	1	1	2	2	2	2	2	3	3		
	L (mm)	953	720	815	1592			1050					
Appearance	W (mm)	353	720	815	974			940					
	H (mm)	1235	1060	1160	1155			1160					
	Weight	kg	135	150	210	210	220	2 × 140	2 × 160	2 × 170	3 × 160	3 × 170	

- Note:
- Declared working condition of refrigerating capacity: Outdoor dry bulb temperature is 35 °C, and wet bulb temperature is 28 °C;
 - The cold and hot type is equipped with electric heating, refer to above table for the electric heating power; while the single cold type doesn't have;
 - The weight of indoor unit equals to that of cold and hot type unit with high-end static pressure;
 - The power supply voltage fluctuation is within ±10% and the three-phase power supply imbalance is within 2%;
 - The user shall not change the refrigerant type without permission;
 - The product design may be changed without further notice.

High-static Pressure Air Duct Blowing-in Type Split AC Unit

High-static pressure air duct blowing-in type split AC unit - All fresh air type/R407C refrigerant [heat pump type/ DFBA** R/Dx]

Parameter		Type	DF12C(AR/DX)	DF17C(AR/DX)	DF22C(AR/DX)	DFBA28R/DX	DFBA32R/DX	DFBA45R/DX	DFBA60R/DX	DFBA70R/DX	DFBA90R/DX	DFBA100R/DX	
Air-conditioning unit performance	Refrigerating capacity	kW	11.4	16.2	20.9	26	30	42	56	66	84.5	95	
		10 ³ kcal/h	0.98	1.39	1.80	2.24	2.58	3.61	4.82	5.68	7.27	8.17	
	Heating capacity	kW	11.88	16.6	21.9	27	32.4	45	60	70	88.5	99.5	
		10 ³ kcal/h	1.02	1.43	1.88	2.32	2.79	3.87	5.16	6.02	7.61	8.56	
	Energy regulation	%	100.0	100.0	100.50.0	100.50.0	100.50.0	100.50.0	100.50.0	100.50.0	100.66.33.0	100.66.33.0	
	Heating capacity	kW	4.5	6	8	9	9	12	12	18	18	24	
		10 ³ kcal/h	0.39	0.52	0.69	0.77	0.77	1.03	1.03	1.55	1.55	2.06	
	Air volume	m ³ /h	1000	1400	1800	2500	3000	4000	5000	6000	8000	9000	
	External static pressure	Pa	60/100/150	60/100/150	100/150/200	80/150/250	80/150/250	80/150/250	80/150/250	80/150/250	120/200/300	150/250/400	
	Unit noise	dB(A)	60/62/63	66/67/69	66/68/69	64/65/67	64/65/67	65/66/69	65/68/70	65/68/70	66/68/72	70/73/75	
	Power supply	3/N/PE AC 380V/220V 50Hz											
	Refrigeration input power under nominal working condition	kW	4.7	6.8	8.8	10.3	11.8	16.2	21.5	25.8	32.5	36.4	
Heating input power under nominal working condition	kW	4.97	6.9	9	6.2	7	9.4	12.5	14	18.37	20.5		
Compressor	Type	Hermetic scroll compressor											
	Working medium used	R407C											
	Control form	External equalizer thermostatic expansion valve											
Refrigerant	Charge Qty (kg)	4.6	5.8	2×4.2	2×3.5	2×4	2×6	2×7	2×8	3×7	3×8		
	Evaporator type	Efficient red copper tube cover aluminum fin											
Fan	Type	Efficient centrifugal fan											
	Qty	1	1	1	1	1	2	2	2	2	2		
Heater	Type	Electric type (level 2)											
	Power	4.5	6	8	9	9	12	12	18	18	24		
Condensate drain	DN20												
Filter	Black double-layer nylon filter screen												
Connecting pipe	Connection type	Threaded connection					Welding						
	Liquid pipe φ (mm)	Φ12	Φ12	2×Φ12	2×Φ12	2×Φ16	2×Φ16	3×Φ16					
Air pipe φ (mm)	Φ19	Φ19	2×Φ19	2×Φ19	2×Φ22	2×Φ28	3×Φ28						
Appearance	L (mm)	1180	1180	1480	1200	1700	1700						
	W (mm)	720	720	820	760	760	820						
	H (mm)	450	450	550	520	520	690						
Weight	kg	80	100	150	100	110	150	160	170	200	220		
Outdoor unit	Type	DW12B	DW17B	DW22B	DWRA28SB	DWRA32SB	DWRA20B	DWRA28B	DWRA32B	DWRA28B	DWRA32B		
	Qty	1	1	1	1	1	2	2	2	3	3		
	Condenser type	Efficient red copper tube cover aluminum fin											
	Condensate fan	Type	High-efficient axial flow fan										
		Qty	2	1	1	1	2	2	2	2	3	3	
	Appearance	L (mm)	953	720	815	1592	1050						
		W (mm)	353	720	815	974	940						
		H (mm)	1235	1060	1160	1155	1160						
	Weight	kg	135	150	210	210	220	2×140	2×160	2×170	3×160	3×170	

- Note:**
- Declared working condition of refrigerating capacity: Outdoor dry bulb temperature is 35 °C and wet bulb temperature is 28 °C;
 - Declared working condition of heating capacity: Air inlet dry bulb temperature of outdoor unit is 7 °C and wet bulb temperature is 6 °C;
 - The standard configuration of heat pump unit is equipped with auxiliary electric heating; if you don't need such function, please specify at the time of ordering; if the outdoor temperature is low, it is recommended to use electric heating to preheat the fresh air when starting heating; the weight of indoor unit equals to that of high-end static pressure unit;
 - The power supply voltage fluctuation is within ±10% and the three-phase power supply imbalance is within 2%;
 - The user shall not change the refrigerant type without permission;
 - The product design may be changed without further notice, please subject to the unit nameplate.

Rooftop Air-conditioning Unit (Split)



Unit Feature

1. Patent fastening type plate and frame case structure, ensure excellent quality;
2. Patent hot-gas bypass technology, super-cooling technology, and two-way expansion valve technology, save energy for unit;
3. Great variety of goods and flexible selection, can meet the application requirements of different occasions and environments;
4. First-class accessories, guarantee superior performance, stable quality, safe and reliable operation;
5. Complete control, make the unit always at the optimal operation state.

Unit Feature

Product Selection

Rooftop Air-conditioning Unit Selection Table

Optional configuration name	Optional configuration
Compressor type	Hermetic scroll type (W) (refrigerating capacity range of 26 kW to 300 kW) Or semi-hermetic screw type (L) (refrigerating capacity range of 245 kW to 300 kW) is optional
Unit feature	Clean type (J) and all fresh air type (x) are optional
Unitary	Thermostatic and humidistatic type (H), single cold type (L) and heat pump type (R) are optional
Heating mode	Electric heating (D), steam heating (Q), and hot water heating (S) are optional
Humidification mode	Dry steam humidification (Z), electrode humidification (J), and wet-film humidification (M) are optional
Refrigerant	R407C(A) and R410A(C) are optional, R22 information is omitted
Nominal refrigerating capacity (kW)	Refer to the technical parameter table (refrigerating capacity range: 26 kW to 450 kW)
Pipe connecting direction of air-handling section	Left connection (Z) and right connection (Y) are optional
Air supply method	Top air supply (A) and end air supply (B)

Note: 1. Judgment criteria for left and right type of unit: At the return air inlet of air-handling section, watch the airflow direction; if the connecting pipe is on the left, it is left type; otherwise, it is right type. By default, the access door is on the opposite side of connecting pipe.

2. Air supply mode: Top air supply mode is defaulted.

Rooftop Air-conditioning Unit (Split)

Clean Type Thermostatic and Humidistatic Unit

Performance		Type	WFWJHQZ100	WFWJHQZ135	WFWJHQZ170	WFWJHQZ200	WFWJHQZ235	WFWJHQZ270
Refrigerating capacity	kW		99	135	171	198	234	270
Air volume	m ³ /h		14500	16000	17500	22000	24000	26000
External static pressure	Pa		600	800	1000	Refer to the unit electrical parameters		
Unit power	kW							
Temperature control and sensitivity	°C							± 1
Humidity control and sensitivity	%							± 8
Unit noise	dB(A)		73	74	75	76	76	76
Operating power supply								3/N/PE AC 380/220V 50Hz
Compressor	Type							Hermetic scroll compressor
Set number			3	4	5	6	7	8
Working medium used								R22/R410A (optional)
Refrigerant	Control form							External equalizer thermostatic expansion valve
Charge Qty (kg)			3 × 10	4 × 10	5 × 10	6 × 10	7 × 10	8 × 10
Condenser type								Efficient red copper tube cover aluminum fin
Condensate fan	Type							High-efficient axial flow fan
Qty			2	2	4	4	4	4
Refrigerant pipe connecting specification	Air pipe		3-φ28	4-φ28	5-φ28	6-φ28	7-φ28	8-φ28
Liquid pipe			3-φ16	4-φ16	5-φ16	6-φ16	7-φ16	8-φ16
Weight	kg		700	800	1230	1400	1500	1600
Blower	Type							Centrifugal type
Heating capacity	(kW)		60	80	100	140	160	180
Electric heater	(kW)		45	60	75	85	100	115
Dry steam humidifier	Qty (kg/h)		40	50	60	70	90	100
Electrode humidifier	Qty (kg/h)		35	45	65	65	65	90
Filter unit								Plate-type primary efficiency G4 + bag-type medium efficiency F7
Evaporator type								Efficient red copper tube cover aluminum fin
Weight	kg		1450	1850	2150	2250	2600	3000

1. If the air-handling section leaves the factory in sections, the dimension shall be the total length of each functional section; 2. Declared working condition of refrigerating capacity: Air inlet dry bulb temperature of use side is 23 °C, and wet bulb temperature is 17 °C, and air inlet dry bulb temperature of condenser is 35 °C; 3. Declared working condition of heating capacity: Steam heating: Steam pressure of 0.2Mpa and air inlet temperature of 20 °C; 4. The fresh air ratio is required to be less than 30%; otherwise, it may influence the temperature, humidity and sensitivity; 5. The unit dimension shall refer to "A". Unit outline dimension for clean-type thermostatic and humidistatic unit"; 6. If the performance parameters conflict with the nameplate, the nameplate parameters shall prevail.

Rooftop Air-conditioning Unit (Split)

Clean Type Thermostatic and Humidistatic Unit

Performance		Type	WFLJHQZ245	WFLJHQZ290	WFLJHQZ345	WFLJHQZ395	WFLJHQZ430
Refrigerating capacity	kW		243	292	345	396	433.7
Air volume	m ³ /h		34500	38000	41500	45000	49000
External static pressure	Pa		41000	45000	49000	54000	57000
Unit power	kW						
Temperature control and sensitivity	°C						
Humidity control and sensitivity	%						
Unit noise	dB(A)		76	76	76	76	77
Operating power supply							
Compressor	Type						
Set number			1	1	1	1	1
Working medium used							
Refrigerant	Control form						
Charge Qty (kg)			110	140	150	170	190
Condenser type							
Condensate fan	Type						
Qty			6	6	8	8	8
Refrigerant pipe connecting specification	Air pipe		2-φ54	2-φ54	2-φ67	2-φ67	2-φ67
Liquid pipe			2-φ28	2-φ28	2-φ35	2-φ35	2-φ35
Weight	kg		2280	2400	2850	3000	3100
Blower	Type						
Heating capacity	(kW)		160	180	200	200	280
Dry steam humidifier	Qty (kg/h)		90	100	110	120	120
Filter unit							
Evaporator type							
Weight	kg		2600	3000	3450	4150	4500

1. If the air-handling section leaves the factory in sections, the dimension shall be the total length of each functional section; 2. Declared working condition of refrigerating capacity: Air inlet dry bulb temperature of use side is 23 °C, and wet bulb temperature is 17 °C, and air inlet dry bulb temperature of condenser is 35 °C; 3. Declared working condition of heating capacity: Steam heating: Steam pressure of 0.2Mpa and air inlet temperature of 20 °C; 4. The fresh air ratio is required to be less than 30%; otherwise, it may influence the temperature, humidity and sensitivity; 5. The unit dimension shall refer to "A". Unit outline dimension for clean-type thermostatic and humidistatic unit"; 6. If the performance parameters conflict with the nameplate, the nameplate parameters shall prevail.

Rooftop Air-conditioning Unit (Split)

Thermostatic and Humidistatic Type

Performance	Type		WFLHQZ100	WFLHQZ135	WFLHQZ170	WFLHQZ200	WFLHQZ235	WFLHQZ270
	Type		WFWHDJ100	WFWHDJ135	WFWHDJ170	WFWHDJ200	WFWHDJ235	WFWHDJ270
Refrigerating capacity	kW		99	135	171	198	234	270
Air volume	m ³ /h		14500	16000	17500	22000	24000	26000
External static pressure	Pa		14500	16000	17500	22000	24000	26000
Unit power	kW		14500	16000	17500	22000	24000	26000
Temperature control and sensitivity	°C		± 1					
Humidity control and sensitivity	%		± 8					
Unit noise	dB(A)		72	72	72	72	73	74
Operating power supply								
3/N/PE AC 380/220V 50HZ								
Compressor								
Type								
Hermetic scroll compressor								
Set number								
3								
Working medium used								
R22/R410A (optional)								
Refrigerant								
Control form								
External equalizer thermostatic expansion valve								
Charge Qty (kg)								
3 × 10								
Condenser type								
Efficient red copper tube cover aluminum fin								
Type								
High-efficient axial flow fan								
Condensate fan								
Type								
Qty								
2								
Refrigerant pipe connecting specification								
Air pipe								
Qty								
3--φ 28								
Liquid pipe								
Qty								
3--φ 16								
Weight								
kg								
700								
Blower								
Type								
Centrifugal type								
Steam heater								
Type								
Heating capacity (kW)								
60								
Electric heater								
Type								
Heating capacity (kW)								
45								
Dry steam humidifier								
Type								
Humidification Qty (kg/h)								
40								
Electrode humidifier								
Type								
Humidification Qty (kg/h)								
35								
Filter unit								
Type								
Plate-type primary efficiency G3								
Evaporator type								
Efficient red copper tube cover aluminum fin								
Weight								
kg								
1200								
Evaporator type								
Efficient red copper tube cover aluminum fin								
Weight								
kg								
1200								

1. If the air-handling section leaves the factory in sections, the dimension shall be the total length of each functional section; 2. Declared working condition of refrigerating capacity: Air inlet dry bulb temperature of use side is 23 °C, and wet bulb temperature is 17 °C; and air inlet dry bulb temperature of condenser is 35 °C; 3. Declared working condition of heating capacity: Steam pressure of 0.2Mpa and air inlet temperature of 20 °C; 4. The fresh air ratio is required to be less than 30%; 5. The unit dimension shall refer to 'B'. Unit outline dimension for clean-type thermostatic and humidistatic unit; 6. If the performance parameters conflict with the nameplate, the nameplate parameters shall prevail.

Rooftop Air-conditioning Unit (Split)

Thermostatic and Humidistatic Type

Performance	Type		WFLHQZ245	WFLHQZ290	WFLHQZ345	WFLHQZ395	WFLHQZ430	
	Refrigerating capacity	kW		243	292	345	396	433.7
Air volume	m ³ /h		34500	38000	41500	45000	49000	
External static pressure	Pa		34500	38000	41500	45000	49000	
Unit power	kW		34500	38000	41500	45000	49000	
Temperature control and sensitivity	°C		± 1					
Humidity control and sensitivity	%		± 8					
Unit noise	dB(A)		74	74	74	75	76	
Operating power supply								
3/N/PE AC 380/220V 50HZ								
Compressor								
Type								
Semi-hermetic screw compressor								
Set number								
1								
Working medium used								
R22								
Refrigerant								
Control form								
External equalizer thermostatic expansion valve								
Charge Qty (kg)								
110								
Condenser type								
Efficient red copper tube cover aluminum fin								
Type								
High-efficient axial flow fan								
Condensate fan								
Type								
Qty								
6								
Refrigerant pipe connecting specification								
Air pipe								
Qty								
2--φ 54								
Liquid pipe								
Qty								
2--φ 28								
Weight								
kg								
2280								
Blower								
Type								
Centrifugal type								
Steam heater								
Type								
Heating capacity (kW)								
160								
Dry steam humidifier								
Type								
Humidification Qty (kg/h)								
90								
Filter unit								
Type								
Plate-type primary efficiency G3								
Evaporator type								
Efficient red copper tube cover aluminum fin								
Weight								
kg								
2200								

1. If the air-handling section leaves the factory in sections, the dimension shall be the total length of each functional section; 2. Declared working condition of refrigerating capacity: Air inlet dry bulb temperature of use side is 23 °C, and wet bulb temperature is 17 °C; and air inlet dry bulb temperature of condenser is 35 °C; 3. Declared working condition of heating capacity: Steam pressure of 0.2Mpa and air inlet temperature of 20 °C; 4. The fresh air ratio is required to be less than 30%; 5. The unit dimension shall refer to 'B'. Unit outline dimension for clean-type thermostatic and humidistatic unit; 6. If the performance parameters conflict with the nameplate, the nameplate parameters shall prevail.

Rooftop Air-conditioning Unit (Split)

Clean-type Heat Pump and Single Cold Unit

Performance	Type		WFWJR(D)28	WFWJR(D)35	WFWJR(D)45	WFWJR(D)60	WFWJR(D)75	WFWJR(D)90	
	Refrigerating capacity	Heating capacity	27.8	34.5	45	60	74.5	91	
Air-conditioning unit performance	Heating capacity	kW	29.5	36.5	48	65	78	96	
	Air volume	m ³ /h	3500	4500	5500	7000	8500	10000	12000
Air-conditioning unit performance	External static pressure	Pa	400,600,800						14800
	Unit power	kW	Refer to the unit electrical parameters						
Air-conditioning unit performance	Temperature control and sensitivity	°C	± 1						
	Humidity control and sensitivity	%	± 8						
Air-conditioning unit performance	Unit noise	dB(A)	70	70	71	71	72	73	
	Operating power supply		3/N/PE AC 380/220V 50Hz						
Compression-condensation section	Compressor	Type	Hermetic scroll compressor						
	Set number		2	2	2	2	2	3	
Compression-condensation section	Refrigerant	Working medium used	R22/R410A (optional)						
	Control form		External equalizer thermostatic expansion valve						
Compression-condensation section	Charges	Qty (kg)	2 × 3.5	2 × 4	2 × 6	2 × 7	2 × 8	3 × 7	
	Condenser type		Efficient red copper tube cover aluminum fin						
Compression-condensation section	Condensate fan	Type	High-efficient axial flow fan						
	Qty		2	2	2	2	2	2	
Compression-condensation section	Refrigerant pipe connecting specification	Air pipe	2-φ19 (threaded interface)						
	Liquid pipe		2-φ16						
Compression-condensation section	Weight	kg	210	220	2*140	2*160	2*170	700	
	Blower	Type	Centrifugal type						
Air-handling section	•Electric heater	Heating capacity (kW)	12	15	18	24	30	36	
	Filter unit		Plate-type primary efficiency G4 + bag-type medium efficiency F7						
Air-handling section	Evaporator type		Efficient red copper tube cover aluminum fin						
	Weight	kg	550	650	850	950	1000	1100	

- If the air-handling section leaves the factory in sections, the dimension shall be the total length of each functional section;
- Declared working condition of refrigerating capacity: Air inlet dry bulb temperature of use side is 27 °C, and wet bulb temperature is 19 °C; and air inlet dry bulb temperature of condenser is 35 °C;
- Declared working condition of unit heating: Air inlet dry bulb temperature of use side is 20 °C, outdoor dry bulb temperature is 7 °C, and wet bulb temperature is 6 °C;
- The unit dimension shall refer to °C. Unit outline dimension for clean-type heat pump and single cold unit*;
- If the performance parameters conflict with the nameplate, the nameplate parameters shall prevail.

Rooftop Air-conditioning Unit (Split)

Clean Type Heat Pump and Single Cold Unit

Performance	Type		WFWJR(D)110	WFWJR(D)150	WFWJR(D)190	WFWJR(D)220	WFWJR(D)260	WFWJR(D)300
	Refrigerating capacity	Heating capacity	109	149.4	189.5	219	258	298
Air-conditioning unit performance	Heating capacity	kW	110.4	151	191.4	222	261	302
	Air volume	m ³ /h	14500	17500	22000	24000	26000	30000
Air-conditioning unit performance	External static pressure	Pa	400,600,800					
	Unit power	kW	Refer to the unit electrical parameters					
Air-conditioning unit performance	Temperature control and sensitivity	°C	± 1					
	Unit noise	dB(A)	73	73	74	74	75	75
Air-conditioning unit performance	Operating power supply		3/N/PE AC 380/220V 50Hz					
	Compressor	Type	Hermetic scroll compressor					
Air-conditioning unit performance	Set number		3	4	5	6	7	8
	Refrigerant	Working medium used	R22/R410A (optional)					
Air-conditioning unit performance	Control form		External equalizer thermostatic expansion valve					
	Charges	Qty (kg)	3 × 10	4 × 10	5 × 10	6 × 10	7 × 10	8 × 10
Compression-condensation section	Condenser type		Efficient red copper tube cover aluminum fin					
	Condensate fan	Type	High-efficient axial flow fan					
Compression-condensation section	Qty		2	2	4	4	4	4
	Refrigerant pipe connecting specification	Air pipe	3-φ28					
Compression-condensation section	Liquid pipe		4-φ16					
	Weight	kg	700	800	1230	1400	1500	1600
Air-handling section	Blower	Type	Centrifugal type					
	•Electric heater	Heating capacity (kW)	24	27	48	60	72	80
Air-handling section	•Steam heater	Heating capacity (kW)	60	80	100	140	160	180
	•Hot water heater	Heating capacity (kW)	60	80	100	140	160	180
Air-handling section	Filter unit		Plate-type primary efficiency G4 + bag-type medium efficiency F7					
	Evaporator type		Efficient red copper tube cover aluminum fin					
Air-handling section	Weight	kg	1200	1600	1850	1950	2300	2600

- If the air-handling section leaves the factory in sections, the dimension shall be the total length of each functional section;
- Declared working condition of refrigerating capacity: Air inlet dry bulb temperature of use side is 27 °C, and wet bulb temperature is 19 °C; and air inlet dry bulb temperature of condenser is 35 °C;
- Declared working condition of unit heating: Air inlet dry bulb temperature of use side is 20 °C, outdoor dry bulb temperature is 7 °C, and wet bulb temperature is 6 °C;
- Steam heating: Steam pressure of 0.2 Mpa; hot water heating: water inlet temperature of 50 °C, and water outlet temperature of 70 °C;
- The unit dimension shall refer to °C. Unit outline dimension for clean-type heat pump and single cold unit*;
- If the performance parameters conflict with the nameplate, the nameplate parameters shall prevail.

Rooftop Air-conditioning Unit (Split)

Clean Type Heat Pump and Single Cold Unit

Performance	Type		WFLJR(D)260	WFLJR(D)310	WFLJR(D)370	WFLJR(D)420
	WFLJL(D)260		WFLJL(D)310	WFLJL(D)370	WFLJL(D)420	WFLJL(D)420
Refrigerating capacity	kW		260	309.5	369.5	421
Heating capacity	kW		265	326.5	378.5	427.5
Air volume	m ³ /h		34500	41000	45000	53000
External static pressure	Pa		41500	49000	45000	54000
Unit power	kW		400,600,800			
Temperature control and sensitivity	°C		Refer to the unit electrical parameters			
Unit noise	dB(A)		74	74	75	75
Operating power supply			3/N/PE AC 380/220V 50Hz			
Compressor	Type		Semi-hermetic screw compressor			
Refrigerant	Set number		1	1	1	1
	Working medium used		R22			
	Control form		External equalizer thermostatic expansion valve			
Condenser type	Charge Qty (kg)		110	140	150	170
	Type		Efficient red copper tube cover aluminum fin High-efficient axial flow fan			
Condensate fan	Type		High-efficient axial flow fan			
	Qty		6	6	8	8
Refrigerant pipe connecting specification	Air pipe		2-φ 54	2-φ 54	2-φ 67	2-φ 67
	Liquid pipe		2-φ 28	2-φ 28	2-φ 35	2-φ 35
Weight	kg		2280	2400	2850	3000
Blower	Type		Centrifugal type			
Air-handling section	●Electric heater	Heating capacity (kW)	72	80	90	108
	○Steam heater	Heating capacity (kW)	160	180	200	280
	●Hot water heater	Heating capacity (kW)	160	180	200	280
Filter unit			Plate-type primary efficiency G4 + bag-type medium efficiency F7			
Evaporator type			Efficient red copper tube cover aluminum fin			
Weight	kg		2300	2600	3100	3700

- If the air-handling section leaves the factory in sections, the dimension shall be the total length of each functional section;
- Declared working condition of refrigerating capacity: Air inlet dry bulb temperature of use side is 27 °C, and wet bulb temperature is 19 °C; and air inlet dry bulb temperature of condenser is 35 °C;
- Declared working condition of unit heating: Air inlet dry bulb temperature of use side is 20 °C, outdoor dry bulb temperature is 7 °C, and wet bulb temperature is 6 °C;
- Steam heating: Steam pressure of 0.2 Mpa; hot water heating: water inlet temperature of 90 °C and water outlet temperature of 70 °C;
- The unit dimension shall refer to 'C'. Unit outline dimension for clean-type heat pump and single cold unit;
- If the performance parameters conflict with the nameplate, the nameplate parameters shall prevail.

Rooftop Air-conditioning Unit (Split)

Heat Pump and Single Cold Type

Performance	Type		WFWR(D)110	WFWR(D)150	WFWR(D)190	WFWR(D)220	WFWR(D)260	WFWR(D)300
	WFWL(D)110		WFWL(D)150	WFWL(D)190	WFWL(D)220	WFWL(D)260	WFWL(D)300	WFWL(D)300
Refrigerating capacity	kW		109	149.4	189.5	219	258	298
Heating capacity	kW		110.4	151	191.4	222	261	302
Air volume	m ³ /h		14500	17500	20000	23000	26000	30000
External static pressure	Pa		16000	22000	24000	26000	30000	36000
Unit power	kW		400,600,800	400,600,800	400,600,800	400,600,800	400,600,800	400,600,800
Temperature control and sensitivity	°C		Refer to the unit electrical parameters					
Unit noise	dB(A)		72	72	72	73	74	74
Operating power supply			3/N/PE AC 380/220V 50Hz					
Compressor	Type		Hermetic scroll compressor					
Refrigerant	Set number		3	4	5	6	7	8
	Working medium used		R22/R410A (optional)					
	Control form		External equalizer thermostatic expansion valve					
Condenser type	Charge Qty (kg)		3 x 10	4 x 10	5 x 10	6 x 10	7 x 10	8 x 10
	Type		Efficient red copper tube cover aluminum fin High-efficient axial flow fan					
Condensate fan	Type		High-efficient axial flow fan					
	Qty		2	2	4	4	4	4
Refrigerant pipe connecting specification	Air pipe		3-φ 28	4-φ 28	5-φ 28	6-φ 28	7-φ 28	8-φ 28
	Liquid pipe		3-φ 16	4-φ 16	5-φ 16	6-φ 16	7-φ 16	8-φ 16
Weight	kg		700	800	1230	1400	1500	1600
Blower	Type		Centrifugal type					
Air-handling section	●Electric heater	Heating capacity (kW)	24	27	48	60	72	80
	○Steam heater	Heating capacity (kW)	60	80	100	140	160	180
	●Hot water heater	Heating capacity (kW)	60	80	100	140	160	180
Filter unit			Plate-type primary efficiency G3					
Evaporator type			Efficient red copper tube cover aluminum fin					
Weight	kg		1150	1400	1650	1750	2050	2400

- If the air-handling section leaves the factory in sections, the dimension shall be the total length of each functional section;
- Declared working condition of refrigerating capacity: Air inlet dry bulb temperature of use side is 27 °C, and wet bulb temperature is 19 °C; and air inlet dry bulb temperature of condenser is 35 °C;
- Declared working condition of unit heating: Air inlet dry bulb temperature of use side is 20 °C, outdoor dry bulb temperature is 7 °C, and wet bulb temperature is 6 °C;
- Steam heating: Steam pressure of 0.2 Mpa; hot water heating: water inlet temperature of 90 °C and water outlet temperature of 70 °C;
- The unit dimension shall refer to 'D'. Unit outline dimension for clean-type heat pump and single cold unit;
- If the performance parameters conflict with the nameplate, the nameplate parameters shall prevail.

Rooftop Air-conditioning Unit (Split)

Heat Pump and Single Cold Type

Performance		Type		WFLR(D)260	WFLR(D)310	WFLR(D)370	WFLR(D)420
Refrigerating capacity	kW	260	309.5	369.5	421		
Heating capacity	kW	265	326.5	378.5	427.5		
Air volume	m ³ /h	34500	41500	49000	54000	53000	64500
External static pressure	Pa	400 ,600 ,800					
Unit power	kW	Refer to the unit electrical parameters					
Temperature control and sensitivity	°C	± 1					
Unit noise	dB(A)	73	74	75	75	75	75
Operating power supply		3/N/PE AC 380/220V 50Hz					
Compressor		Semi-hermetic screw compressor					
Type							
Set number		1	1	1	1	1	1
Working medium used		R22					
Control form		External equalizer thermostatic expansion valve					
Charge Qty (kg)		110	140	150	170		
Condenser type		Efficient red copper tube cover aluminum fin					
Type		High-efficient axial flow fan					
Condensate fan							
Type		6	6	8	8		
Qty							
Refrigerant pipe connecting specification							
Air pipe		2-φ 54	2-φ 54	2-φ 67	2-φ 67	2-φ 67	2-φ 67
Liquid pipe		2-φ 28	2-φ 28	2-φ 35	2-φ 35	2-φ 35	2-φ 35
Weight	kg	2280	2400	2850	3000		
Blower		Centrifugal type					
Type							
Heating capacity (kW)		72	80	90	108		
Heating capacity (kW)		160	180	200	280		
Heating capacity (kW)		160	180	200	280		
Filter unit		Plate-type primary efficiency G3					
Evaporator type		Efficient red copper tube cover aluminum fin					
Weight	kg	2050	2400	2750	3300		

- If the air-handling section leaves the factory in sections, the dimension shall be the total length of each functional section;
- Declared working condition of refrigerating capacity: Air inlet dry bulb temperature of use side is 27 °C, and wet bulb temperature of condenser is 35 °C;
- Declared working condition of unit heating: Air inlet dry bulb temperature of use side is 20 °C, outdoor dry bulb temperature is 7 °C, and wet bulb temperature is 6 °C;
- Steam heating: Steam pressure of 0.2 Mpa; hot water heating: water inlet temperature of 90 °C and water outlet temperature of 70 °C;
- The unit dimension shall refer to "D". Unit outline dimension for clean-type heat pump and single cold unit;
- If the performance parameters conflict with the nameplate, the nameplate parameters shall prevail.

Rooftop Air-conditioning Unit (Split)

Heat Pump and Single Cold Type (All Fresh Air Type)

Performance		Type		WFWXR(D)110	WFWXR(D)150	WFWXR(D)190	WFWXR(D)220	WFWXR(D)260	WFWXR(D)300
Refrigerating capacity	kW	109	149.4	189.5	219	258	298		
Heating capacity	kW	110.4	151	191.4	222	261	302		
Air volume	m ³ /h	8800	9800	10500	11000	12000	13000	14500	16000
External static pressure	Pa	400 ,600 ,800							
Unit power	kW	Refer to the unit electrical parameters							
Temperature control and sensitivity	°C	± 1							
Unit noise	dB(A)	72	72	72	72	73	74	74	74
Operating power supply		3/N/PE AC 380/220V 50Hz							
Compressor		Hermetic scroll compressor							
Type									
Set number		3	4	5	6	7	8		
Working medium used		R22/R410A (optional)							
Control form		External equalizer thermostatic expansion valve							
Charge Qty (kg)		3 × 9	4 × 9	5 × 9	6 × 9	7 × 9	8 × 9		
Condenser type		Efficient red copper tube cover aluminum fin							
Type		High-efficient axial flow fan							
Condensate fan									
Type		2	2	4	4	4	4	4	4
Qty									
Refrigerant pipe connecting specification									
Air pipe		3-φ 28	4-φ 28	5-φ 28	6-φ 28	7-φ 28	8-φ 28	8-φ 28	8-φ 28
Liquid pipe		3-φ 16	4-φ 16	5-φ 16	6-φ 16	7-φ 16	8-φ 16	8-φ 16	8-φ 16
Weight	kg	700	800	1230	1400	1500	1600		
Blower		Centrifugal type							
Type									
Heating capacity (kW)		24	27	48	60	72	80		
Heating capacity (kW)		60	80	100	140	160	180		
Heating capacity (kW)		60	80	100	140	160	180		
Filter unit		Plate-type primary efficiency G3							
Evaporator type		Efficient red copper tube cover aluminum fin							
Weight	kg	750	850	1050	1250	1450	1600		

- If the air-handling section leaves the factory in sections, the dimension shall be the total length of each functional section;
- Declared working condition of refrigerating capacity: Air inlet dry bulb temperature of use side is 35 °C, and wet bulb temperature of condenser is 35 °C;
- Declared working condition of unit heating: Air inlet dry bulb temperature of use side is 7 °C, and wet bulb temperature of 6 °C; outdoor dry bulb temperature is 7 °C, and wet bulb temperature is 6 °C;
- Steam heating: Steam pressure of 0.2 Mpa; hot water heating: water inlet temperature of 90 °C and water outlet temperature of 70 °C;
- The unit dimension shall refer to "D". Unit outline dimension for all fresh air type heat pump and single cold unit;
- If the performance parameters conflict with the nameplate, the nameplate parameters shall prevail.

Rooftop Air-conditioning Unit (Split)

Heat Pump and Single Cold Type (All Fresh Air Type)

Performance	Type		WFLXR(D)260		WFLXR(D)310		WFLXR(D)370		WFLXR(D)420		
	Refrigerating capacity	Heating capacity	260	309.5	326.5	369.5	421	427.5	31000	37000	
Air-conditioning unit performance	Air volume	m ³ /h	200.00	220.00	240.00	230.00	250.00	275.00	260.00	310.00	
	External static pressure	Pa	265	240.00	230.00	250.00	275.00	260.00	310.00	370.00	
Air-conditioning unit performance	Unit power	kW	200.00	220.00	240.00	230.00	250.00	275.00	260.00	310.00	
	Temperature control and sensitivity	°C	± 1	Refer to the unit electrical parameters							
Unit noise	dB(A)	74	74	74	74	74	75	75	75	75	
Operating power supply	3/N/PE AC 380/220V 50Hz										
Compressor	Type	Semi-hermetic screw compressor									
Set number	1	1	1	1	1	1	1	1	1	1	
Working medium used	R22										
Refrigerant control form	External equalizer thermostatic expansion valve										
Charge Qty (kg)	110	140	140	140	140	140	150	150	170	170	
Condenser type	High-efficient axial flow fan										
Condensate fan	Type	Centrifugal type									
Qty	6	6	6	6	6	6	8	8	8	8	
Refrigerant pipe connecting specification	Air pipe	2-φ 54		2-φ 54		2-φ 67		2-φ 67		2-φ 67	
Liquid pipe	2-φ 28		2-φ 28		2-φ 28		2-φ 35		2-φ 35		
Weight	kg	2280	2400	2400	2400	2400	2850	2850	3000	3000	
Blower	Type	Centrifugal type									
Heating capacity	Electric heater (kW)	72	80	80	80	80	90	90	108	108	
Steam heater (kW)	160	160	160	160	160	160	200	200	280	280	
Hot water heater (kW)	160	160	160	160	160	160	200	200	280	280	
Filter unit	Plate-type primary efficiency G3										
Evaporator type	Efficient red copper tube cover aluminum fin										
Weight	kg	1450	1450	1450	1450	1450	1600	1600	1700	2000	

1. If the air-handling section leaves the factory in sections, the dimension shall be the total length of each functional section;
 2. Declared working condition of refrigerating capacity: Air inlet dry bulb temperature of use side is 35 °C, and wet bulb temperature is 28 °C; and air inlet dry bulb temperature of condenser is 35 °C; and wet bulb temperature of condenser is 28 °C;
 3. Declared working condition of unit heating: Air inlet dry bulb temperature of use side is 7 °C, and wet bulb temperature of 6 °C; outdoor dry bulb temperature is 7 °C, and wet bulb temperature is 6 °C; steam heating: Steam pressure of 0.2 MPa; hot water heating: water inlet temperature of 90 °C and water outlet temperature of 70 °C;
 4. The unit dimension shall refer to "E". Unit outline dimension for all fresh air type heat pump and single cold unit;
 5. If the performance parameters conflict with the nameplate, the nameplate parameters shall prevail.

Rooftop Air-conditioning Unit (Integral)



Unit Feature

1. Adopt steel and aluminum composite profile and step-type continuous seamless elastomeric sealing technology, so the frame strength and air leakage rate is better than the European standard;
2. Adopt environmental protection R410A compressor in parallel connection + hot-gas bypass to realize multiple level adjustment technology and improve comprehensive energy efficiency of partial load;
3. Adopt electronic expansion valve control technology, to realize proportional flow control, stability and energy saving;
4. Great variety of goods and flexible selection, can meet the application requirements of different occasions and environments;
5. First-class accessories, guarantee superior performance, stable quality, safe and reliable operation;
6. Complete control, make the unit always at the optimal operation state.

A-Side-supply and side-return

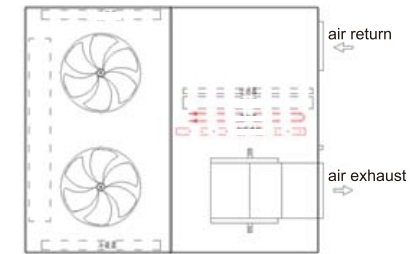

(25kW ~ 91.5kW)

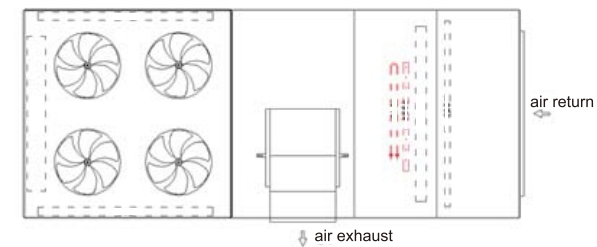

(108.4kW ~ 200kW)

Rooftop Air-conditioning Unit (Integral)

B-Bottom-supply and down-return

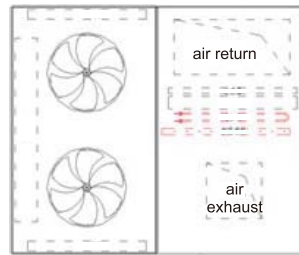

(25kW ~ 91.5kW)

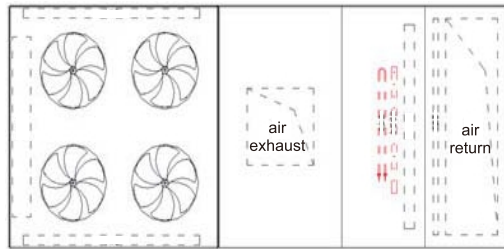

(108.4kW ~ 200kW)

Please write down the unit model you required according to the following unit model representation method:

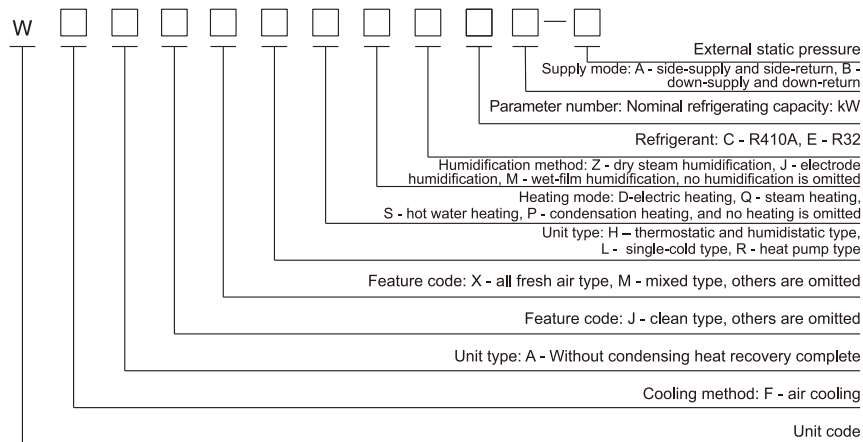

Example:

(1) If an integral rooftop unit has the nominal refrigerating capacity of 55kW, equipped with return air type heat pump and auxiliary electric heating, with the refrigerant of R410A, filtration grade of G3+F5, air supply mode of side-supply and side-return, and external static pressure of 300Pa, the unit model shall be WFAJRDC 55A-300;

(2) If an integral rooftop unit has the nominal refrigerating capacity of 90 kW, equipped with all fresh air type cold and hot (heating) unit and wet-film humidification, with the refrigerant of R410A, filtration grade of G3, air supply mode of down-supply, and external static pressure 350 Pa, the unit model shall be WFAxRMC90B-350.

Rooftop Air-conditioning Unit (Integral)

Heat Pump and Single Cold Type (Performance Parameter Table 1)

Unit model		WFARC28-250	WFARC35-250	WFARC45-320	WFARC55-320	
		WFALC28-250	WFALC35-250	WFALC45-320	WFALC55-320	
Performance	Operating power supply	3/N/PE AC 380/220V 50Hz				
	Refrigerating capacity 1*	kW	28.5	35.2	45.8	55.1
	Heating capacity 2*	kW	308	37.2	48.5	57.8
	Unit power	kW	10.6	13.1	17.3	19.2
	Temperature control and sensitivity 3*	°C	±2			
Capacity control	%	0/50/100	0/50/100	0/50/100	0/50/100	
Compressor	Type	Hermetic scroll parallel compressor				
	Qty	/	2	2	2	2
Refrigerant	Working medium used	R410A				
	Control mode	Electronic expansion valve				
	Charge Qty	kg	7	7	12.5	14
Blower	Type	Centrifugal type				
	Drive mode	Belt drive				
	Air volume	m ³ /h	5800	6500	9000	10000
	External static pressure	Pa	250	250	320	320
	Motor power	kW	2.2	2.2	3	3
Condensate fan	Type	High-efficient axial flow fan				
	Qty	/	2	2	2	2
	Air volume	m ³ /h	7000×2	7000×2	11000×2	11600×2
	Input power	kW	0.4 ×2	0.4 ×2	0.7 ×2	0.9 ×2
Electric heating	Auxiliary heating capacity 4*	kW	9	12	15	18
Evaporator and condenser	Type	Efficient inner-grooved copper tube cover aluminum fin				
Filter	Type and level	Plate-type G3				
Electrical parameters - Without electric heating	Max. running current	A	26.68	30.08	38.84	43.98
	Recommended power cord diameter	mm ²	6	10	16	16
Electrical parameters - With electric heating	Max. running current	A	40.32	48.26	61.57	71.25
	Recommended power cord diameter	mm ²	16	16	25	35
Unit dimension	L x W x H	mm	1870×1700×1770	1870×1700×1770	2370×2000×1970	2370×2000×2000
Unit weight	kg	700	710	986	1042	
Noise	dB(A)	64	64	66	68	

Remarks

1. Declared working condition of refrigerating capacity: OA: DB(A)=35 °C; RA: DB(A)=27°C, WB=19°C;
2. Declared working condition of heating capacity: OA: DB(A)=7°C, WB=6°C; RA: DB(A)= 20°C ;
3. For heat pump and single cold type, the control target is return air temperature of unit;
4. The auxiliary heating capacity is optional; when the required auxiliary heating capacity differs from that of sample, please contact out technical staff;
5. If the performance parameters of non-standard product samples conflict with the nameplate, the nameplate parameters shall prevail.

Rooftop Air-conditioning Unit (Integral)

Heat Pump and Single Cold Type (Performance Parameter Table 2)

Unit model		WFARC70-400	WFARC90-400	WFARC110-500	
		WFALC70-400	WFALC90-400	WFALC110-500	
Performance	Operating power supply		3/N/PE AC 380/220V 50Hz		
	Refrigerating capacity 1*	kW	70.2	91.5	108.4
	Heating capacity 2*	kW	72.6	94.5	111.1
	Unit power	kW	26.5	34.2	41
	Temperature control and sensitivity 3*	°C	±2		
	Capacity control	%	0/50/100	0/50/100	0/25/50/75/100
Compressor	Type		Hermetic scroll parallel compressor		
	Qty	/	2	2	4
Refrigerant	Working medium used		R410A		
	Control mode		Electronic expansion valve		
	Charge Qty	kg	17	18	14×2
Blower	Type		Centrifugal type		
	Drive mode		Belt drive		
	Air volume	m³/h	14000	18000	20000
	External static pressure	Pa	400	400	500
	Motor power	kW	5.5	7.5	7.5
Condensate fan	Type		High-efficient axial flow fan		
	Qty	/	2	2	4
	Air volume	m³/h	15000×2	18000×2	12400×4
	Input power	kW	1.1×2	1.25×2	0.9×4
Electric heating	Auxiliary heating capacity 4*	kW	24	30	33
Evaporator and condenser	Type		Efficient inner-grooved copper tube cover aluminum fin		
Filter	Type and level		Plate-type G3		
Electrical parameters - Without electric heating	Max. running current	A	57.05	73.16	89.96
	Recommended power cord diameter	mm²	25	35	50
Electrical parameters - With electric heating	Max. running current	A	93.41	118.61	139.96
	Recommended power cord diameter	mm²	50	70	95
Unit dimension	L x W x H	mm	2900×2300×2200	2900×2300×2200	4800×2000×2200
Unit weight		kg	1333	1372	1873
Noise		dB(A)	71	75	76

Remarks

1. Declared working condition of refrigerating capacity: OA: DB(A)=35 °C; RA: DB(A)=27°C, WB=19°C;
2. Declared working condition of heating capacity: OA: DB(A)=7°C, WB=6°C; RA: DB(A)= 20°C ;
3. For heat pump and single cold type, the control target is return air temperature of unit;
4. The auxiliary heating capacity is optional; when the required auxiliary heating capacity differs from that of sample, please contact out technical staff;
5. If the performance parameters of non-standard product samples conflict with the nameplate, the nameplate parameters shall prevail.

Rooftop Air-conditioning Unit (Integral)

Heat Pump and Single Cold Type (Performance Parameter Table 3)

Unit model		WFARC125-500	WFARC140-550	WFARC180-550	
		WFALC125-500	WFALC140-550	WFALC180-550	
Performance	Operating power supply		3/N/PE AC 380/220V 50Hz		
	Refrigerating capacity 1*	kW	126	140.5	180.8
	Heating capacity 2*	kW	130.4	144.6	186
	Unit power	kW	47.6	52.1	68.6
	Temperature control and sensitivity 3*	°C	±2		
	Capacity control	%	0/25/50/75/100	0/25/50/75/100	0/25/50/75/100
Compressor	Type		Hermetic scroll parallel compressor		
	Qty	/	4	4	4
Refrigerant	Working medium used		R410A		
	Control mode		Electronic expansion valve		
	Charge Qty	kg	14×2	17×2	18×2
Blower	Type		Centrifugal type		
	Drive mode		Belt drive		
	Air volume	m³/h	22500	27000	32000
	External static pressure	Pa	500	550	550
	Motor power	kW	11	11	15
Condensate fan	Type		High-efficient axial flow fan		
	Qty	/	4	4	4
	Air volume	m³/h	11600×4	15000×4	18000×4
	Input power	kW	0.9×4	1.1×4	1.25×4
Electric heating	Auxiliary heating capacity 4*	kW	39	45	54
Evaporator and condenser	Type		Efficient inner-grooved copper tube cover aluminum fin		
Filter	Type and level		Plate-type G3		
Electrical parameters - Without electric heating	Max. running current	A	105.46	113.00	145.22
	Recommended power cord diameter	mm²	70	70	95
Electrical parameters - With electric heating	Max. running current	A	164.55	181.18	227.04
	Recommended power cord diameter	mm²	120	120	150
Unit dimension	L x W x H	mm	4800×2000×2200	5300×2300×2400	5300×2300×2400
Unit weight		kg	1945	2375	2443
Noise		dB(A)	76	78	78

Remarks

1. Declared working condition of refrigerating capacity: OA: DB(A)=35 °C; RA: DB(A)=27°C, WB=19°C;
2. Declared working condition of heating capacity: OA: DB(A)=7°C, WB=6°C; RA: DB(A)= 20°C ;
3. For heat pump and single cold type, the control target is return air temperature of unit;
4. The auxiliary heating capacity is optional; when the required auxiliary heating capacity differs from that of sample, please contact out technical staff;
5. If the performance parameters of non-standard product samples conflict with the nameplate, the nameplate parameters shall prevail.

Rooftop Air-conditioning Unit (Integral)

Clean-type Heat Pump and Single Cold Type (Performance Parameter Table 4)

Unit model			WFAJRC28-250	WFAJRC35-250	WFAJRC45-320	WFAJRC55-320	
			WFAJLC28-250	WFAJLC35-250	WFAJLC45-320	WFAJLC55-320	
Performance	Operating power supply		3/N/PE AC 380/220V 50Hz				
	Refrigerating capacity 1*	kW	28.5	35.2	45.8	55.1	
	Heating capacity 2*	kW	30.8	37.2	48.5	57.8	
	Unit power	kW	10.89	13.4	17.7	20.5	
	Temperature control and sensitivity 3*	°C	±2				
	Capacity control	%	0/50/100	0/50/100	0/50/100	0/50/100	
Compressor	Type		Hermetic scroll parallel compressor				
	Qty	/	2	2	2	2	
Refrigerant	Working medium used		R410A				
	Control mode		Electronic expansion valve				
	Charge Qty	kg	7	7	12.5	14	
Blower	Type		Centrifugal type				
	Drive mode		Belt drive				
	Air volume	m³/h	5800	6500	9000	10000	
	External static pressure	Pa	250	250	320	320	
	Motor power	kW	2.2	3	3	4	
Condensate fan	Type		High-efficient axial flow fan				
	Qty	/	2	2	2	2	
	Air volume	m³/h	7000×2	7000×2	11000×2	11600×2	
Electric heating	Auxiliary heating capacity 4*		kW	9	12	15	18
	Type		Efficient inner-grooved copper tube cover aluminum fin				
Filter	Type and level		Plate-type G3 + Plate-type F5				
Electrical parameters - Without electric heating	Max. running current	A	26.68	31.68	38.84	45.98	
	Recommended power cord diameter	mm²	6	10	16	16	
Electrical parameters - With electric heating	Max. running current	A	40.32	49.86	61.57	73.25	
	Recommended power cord diameter	mm²	16	16	25	35	
Unit dimension	L x W x H	mm	1870×1700×1770	1870×1700×1770	2370×2000×1970	2370×2000×2000	
Unit weight	kg	704	714	990	1046		
Noise	dB(A)	64	64	66	68		

Remarks

1. Declared working condition of refrigerating capacity: OA: DB(A)=35 °C; RA: DB(A)=27°C, WB=19°C;
2. Declared working condition of heating capacity: OA: DB(A)=7°C, WB=6°C; RA: DB(A)= 20°C ;
3. For heat pump and single cold type, the control target is return air temperature of unit;
4. The auxiliary heating capacity is optional; when the required auxiliary heating capacity differs from that of sample, please contact out technical staff;
5. If the performance parameters of non-standard product samples conflict with the nameplate, the nameplate parameters shall prevail.

Rooftop Air-conditioning Unit (Integral)

Clean-type Heat Pump and Single Cold Type (Performance Parameter Table 5)

Unit model			WFAJRC70-400	WFAJRC90-400	WFAJRC110-500	
			WFAJLC70-400	WFAJLC90-400	WFAJLC110-500	
Performance	Operating power supply		3/N/PE AC 380/220V 50Hz			
	Refrigerating capacity 1*	kW	70.2	91.5	108.4	
	Heating capacity 2*	kW	72.6	94.5	111.1	
	Unit power	kW	27.1	34.7	41.7	
	Temperature control and sensitivity 3*	°C	±2			
	Capacity control	%	0/50/100	0/50/100	0/25/50/75/100	
Compressor	Type		Hermetic scroll parallel compressor			
	Qty	/	2	2	4	
Refrigerant	Working medium used		R410A			
	Control mode		Electronic expansion valve			
	Charge Qty	kg	17	18	14×2	
Blower	Type		Centrifugal type			
	Drive mode		Belt drive			
	Air volume	m³/h	14000	18000	20000	
	External static pressure	Pa	400	400	500	
	Motor power	kW	5.5	7.5	11	
Condensate fan	Type		High-efficient axial flow fan			
	Qty		2	2	4	
	Air volume	m³/h	15000×2	18000×2	12400×4	
	Input power	kW	1.1 ×2	1.25 ×2	0.9 ×4	
Electric heating	Auxiliary heating capacity 4*		kW	24	30	33
Evaporator and condenser	Type		Efficient inner-grooved copper tube cover aluminum fin			
Filter	Type and level		Plate-type G3 + Plate-type F5			
Electrical parameters - Without electric heating	Max. running current	A	57.05	73.16	96.66	
	Recommended power cord diameter	mm²	25	35	50	
Electrical parameters - With electric heating	Max. running current	A	93.41	118.61	146.66	
	Recommended power cord diameter	mm²	50	70	95	
Unit dimension	L x W x H	mm	2900×2300×2200	2900×2300×2200	4800×2000×2200	
Unit weight	kg	1340	1379	1880		
Noise	dB(A)	71	75	76		

Remarks

1. Declared working condition of refrigerating capacity: OA: DB(A)=35 °C; RA: DB(A)=27°C, WB=19°C;
2. Declared working condition of heating capacity: OA: DB(A)=7°C, WB=6°C; RA: DB(A)= 20°C ;
3. For heat pump and single cold type, the control target is return air temperature of unit;
4. The auxiliary heating capacity is optional; when the required auxiliary heating capacity differs from that of sample, please contact out technical staff;
5. If the performance parameters of non-standard product samples conflict with the nameplate, the nameplate parameters shall prevail.

Rooftop Air-conditioning Unit (Integral)

Clean-type Heat Pump and Single Cold Type (Performance Parameter Table 6)

Unit model		WFAJRC125-500		WFAJRC140-550		WFAJRC180-550	
		WFAJLC125-500		WFAJLC140-550		WFAJLC180-550	
Performance	Operating power supply		3/N/PE AC 380/220V 50Hz				
	Refrigerating capacity 1*	kW	126	140.5	180.8		
	Heating capacity 2*	kW	130.4	144.6	186		
	Unit power	kW	49.1	53.6	70.4		
	Temperature control and sensitivity 3*	°C	±2				
	Capacity control	%	0/25/50/75/100	0/25/50/75/100	0/25/50/75/100		
Compressor	Type		Hermetic scroll parallel compressor				
	Qty	/	4	4	4		
Refrigerant	Working medium used		R410A				
	Control mode		Electronic expansion valve				
	Charge Qty	kg	14×2	17×2	18×2		
Blower	Type		Centrifugal type				
	Drive mode		Belt drive				
	Air volume	m³/h	22500	27000	32000		
	External static pressure	Pa	500	550	550		
	Motor power	kW	11	15	15		
Condensate fan	Type		High-efficient axial flow fan				
	Qty	/	4	4	4		
	Air volume	m³/h	11600×4	15000×4	18000×4		
	Input power	kW	0.9×4	1.1×4	1.25×4		
Electric heating	Auxiliary heating capacity 4*	kW	39	45	54		
Evaporator and condenser	Type		Efficient inner-grooved copper tube cover aluminum fin				
Filter	Type and level		Plate-type G3 + Plate-type F5				
Electrical parameters - Without electric heating	Max. running current	A	105.46	120.80	145.22		
	Recommended power cord diameter	mm²	70	70	95		
Electrical parameters - With electric heating	Max. running current	A	164.55	188.98	227.04		
	Recommended power cord diameter	mm²	120	120	150		
Unit dimension	L x W x H	mm	4800×2000×2200	5300×2300×2400	5300×2300×2400		
Unit weight	kg	1952	2382	2450			
Noise	dB(A)	76	78	78			

Remarks

1. Declared working condition of refrigerating capacity: OA: DB(A)=35°C; RA: DB(A)=27°C, WB=19°C;
2. Declared working condition of heating capacity: OA: DB(A)=7°C, WB=6°C; RA: DB(A)=20°C;
3. For clean-type heat pump and single cold type, the control target is return air temperature of unit;
4. The auxiliary heating capacity is optional; when the required auxiliary heating capacity differs from that of sample, please contact out technical staff;
5. If the performance parameters of non-standard product samples conflict with the nameplate, the nameplate parameters shall prevail.

Rooftop Air-conditioning Unit (Integral)

All Fresh Air Type Heat Pump and Single Cold Unit (Performance Parameter Table 7)

Unit model		WFAXRC28-250		WFAXRC35-250		WFAXRC45-320		WFAXRC55-320	
		WFAXLC28-250		WFAXLC35-250		WFAXLC45-320		WFAXLC55-320	
Performance	Operating power supply		3/N/PE AC 380/220V 50Hz						
	Refrigerating capacity 1*	kW	28.5	35.2	45.8	55.1			
	Heating capacity 2*	kW	30.8	37.2	48.5	57.8			
	Unit power	kW	9.6	11.8	15.9	18.5			
	Temperature control and sensitivity 3*	°C	Refrigeration of 15-19 °C, and heating of 20-30 °C						
	Capacity control	%	0/25/50/75/100	0/25/50/75/100	0/25/50/75/100	0/25/50/75/100			
Compressor	Type		Hermetic scroll parallel compressor						
	Qty	/	2	2	2	2			
Refrigerant	Working medium used		R410A						
	Control mode		Electronic expansion valve						
	Charge Qty	kg	7	7	12.5	14			
Blower	Type		Centrifugal type						
	Drive mode		Belt drive						
	Air volume	m³/h	2400	2850	3680	4500			
	External static pressure	Pa	250	250	320	320			
	Motor power	kW	0.55	0.75	1.1	1.5			
Condensate fan	Type		High-efficient axial flow fan						
	Qty	/	2	2	2	2			
	Air volume	m³/h	7000×2	7000×2	11000×2	11600×2			
	Input power	kW	0.4×2	0.4×2	0.7×2	0.9×2			
Electric heating	Auxiliary heating capacity 4*	kW	9	12	15	18			
Evaporator and condenser	Type		Efficient inner-grooved copper tube cover aluminum fin						
Filter	Type and level		Plate-type G3						
Electrical parameters - Without electric heating	Max. running current	A	23.08	26.88	34.94	40.88			
	Recommended power cord diameter	mm²	6	6	10	16			
Electrical parameters - With electric heating	Max. running current	A	36.72	45.06	57.67	68.15			
	Recommended power cord diameter	mm²	10	16	25	35			
Unit dimension	L x W x H	mm	1870×1700×1770	1870×1700×1770	2370×2000×1970	2370×2000×2000			
Unit weight	kg	700	710	986	1042				
Noise	dB(A)	64	64	66	68				

Remarks

1. Declared working condition of refrigerating capacity: OA: DB(A)=35°C, WB=28°C;
2. Declared working condition of heating capacity: OA: DB(A)=7°C; WB=6°C;
3. For all fresh air type heat pump and single cold unit, the control target is supply air temperature of unit;
4. The auxiliary heating capacity is optional; when the required auxiliary heating capacity differs from that of sample, please contact out technical staff;
5. If the performance parameters of non-standard product samples conflict with the nameplate, the nameplate parameters shall prevail.

Rooftop Air-conditioning Unit (Integral)

All Fresh Air Type Heat Pump and Single Cold Unit (Performance Parameter Table 8)

Unit model			WFAXRC70-320	WFAXRC90-400	WFAXRC110-500
			WFAXLC70-320	WFAXLC90-400	WFAXLC110-500
Performance	Operating power supply		3/N/PE AC 380/220V 50Hz		
	Refrigerating capacity 1*	kW	70.2	91.5	108.4
	Heating capacity 2*	kW	72.6	94.5	111.1
	Unit power	kW	23.8	30.7	37
	Temperature control and sensitivity 3*	°C	Refrigeration of 15-19 °C, and heating of 20-30 °C		
	Capacity control	%	0/25/50/75/100	0/25/50/75/100	0/25/50/75/100
Compressor	Type		Hermetic scroll parallel compressor		
	Qty	/	2	2	4
Refrigerant	Working medium used		R410A		
	Control mode		Electronic expansion valve		
	Charge Qty	kg	17	18	14×2
Blower	Type		Centrifugal type		
	Drive mode		Belt drive		
	Air volume	m³/h	5600	7320	8580
	External static pressure	Pa	320	400	500
	Motor power	kW	2.2	2.2	3
Condensate fan	Type		High-efficient axial flow fan		
	Qty	/	2	2	4
	Air volume	m³/h	15000×2	18000×2	12400×4
	Input power	kW	1.1 × 2	1.25 × 2	0.9 × 4
Electric heating	Auxiliary heating capacity 4*	kW	24	30	33
Evaporator and condenser	Type		Efficient inner-grooved copper tube cover aluminum fin		
Filter	Type and level		Plate-type G3		
Electrical parameters - Without electric heating	Max. running current	A	50.55	62.76	81.16
	Recommended power cord diameter	mm²	16	25	50
Electrical parameters - With electric heating	Max. running current	A	86.91	108.21	131.16
	Recommended power cord diameter	mm²	50	70	95
Unit dimension	L x W x H	mm	2900×2300×2200	2900×2300×2200	4800×2000×2200
Unit weight	kg	1333	1372	1873	
Noise	dB(A)	71	75	76	

Remarks

1. Declared working condition of refrigerating capacity: OA: DB(A)=35°C, WB=28°C;
2. Declared working condition of heating capacity: OA: DB(A)=7°C; WB=6°C;
3. For all fresh air type heat pump and single cold unit, the control target is supply air temperature of unit;
4. The auxiliary heating capacity is optional; when the required auxiliary heating capacity differs from that of sample, please contact out technical staff;
5. If the performance parameters of non-standard product samples conflict with the nameplate, the nameplate parameters shall prevail.

Rooftop Air-conditioning Unit (Integral)

All Fresh Air Type Heat Pump and Single Cold Unit (Performance Parameter Table 9)

Unit model			WFAXRC125-500	WFAXRC140-550	WFAXRC180-550
			WFAXLC125-500	WFAXLC140-550	WFAXLC180-550
Performance	Operating power supply		3/N/PE AC 380/220V 50Hz		
	Refrigerating capacity 1*	kW	126	140.5	180.8
	Heating capacity 2*	kW	130.4	144.6	186
	Unit power	kW	42.8	47.5	62.5
	Temperature control and sensitivity 3*	°C	Refrigeration of 15-19 °C, and heating of 20-30 °C		
	Capacity control	%	0/25/50/75/100	0/25/50/75/100	0/25/50/75/100
Compressor	Type		Hermetic scroll parallel compressor		
	Qty	/	4	4	4
Refrigerant	Working medium used		R410A		
	Control mode		Electronic expansion valve		
	Charge Qty	kg	14×2	18×2	18×2
Blower	Type		Centrifugal type		
	Drive mode		Belt drive		
	Air volume	m³/h	10000	12500	15000
	External static pressure	Pa	500	550	550
	Motor power	kW	4	5.5	5.5
Condensate fan	Type		High-efficient axial flow fan		
	Qty	/	4	4	4
	Air volume	m³/h	11600×4	15000×4	18000×4
	Input power	kW	0.9 × 4	1.1 × 4	1.25 × 4
Electric heating	Auxiliary heating capacity 4*	kW	39	45	54
Evaporator and condenser	Type		Efficient inner-grooved copper tube cover aluminum fin		
Filter	Type and level		Plate-type G3		
Electrical parameters - Without electric heating	Max. running current	A	91.96	102.40	126.82
	Recommended power cord diameter	mm²	50	50	70
Electrical parameters - With electric heating	Max. running current	A	151.05	170.58	208.64
	Recommended power cord diameter	mm²	95	120	150
Unit dimension	L x W x H	mm	4800×2000×2200	5300×2300×2400	5300×2300×2400
Unit weight	kg	1945	2375	2443	
Noise	dB(A)	76	78	78	

Remarks

1. Declared working condition of refrigerating capacity: OA: DB(A)=35°C, WB=28°C;
2. Declared working condition of heating capacity: OA: DB(A)=7°C; WB=6°C;
3. For all fresh air type heat pump and single cold unit, the control target is supply air temperature of unit;
4. The auxiliary heating capacity is optional; when the required auxiliary heating capacity differs from that of sample, please contact out technical staff;
5. If the performance parameters of non-standard product samples conflict with the nameplate, the nameplate parameters shall prevail.

Rooftop Air-conditioning Unit (Integral)

Clean-type All Fresh Air Heat Pump and Single Cold Unit (Performance Parameter Table 10)

Unit model			WFAJXRC28-250	WFAJXRC35-250	WFAJXRC45-320	WFAJXRC55-320
			WFAJXLC28-250	WFAJXLC35-250	WFAJXLC45-320	WFAJXLC55-320
Performance	Operating power supply		3/N/PE AC 380/220V 50Hz			
	Refrigerating capacity 1*	kW	28.5	35.2	45.8	55.1
	Heating capacity 2*	kW	30.8	37.2	48.5	57.8
	Unit power	kW	9.89	12.2	16.3	19.2
	Temperature control and sensitivity 3*	°C	Refrigeration of 15-19 °C, and heating of 20-30 °C			
	Capacity control	%	0/25/50/75/100	0/25/50/75/100	0/25/50/75/100	0/25/50/75/100
Compressor	Type		Hermetic scroll parallel compressor			
	Qty	/	2	2	2	2
Refrigerant	Working medium used		R410A			
	Control mode		Electronic expansion valve			
	Charge Qty	kg	7	7	12.5	14
Blower	Type		Centrifugal type			
	Drive mode		Belt drive			
	Air volume	m ³ /h	2400	2850	3680	4500
	External static pressure	Pa	250	250	320	320
	Motor power	kW	0.75	1.1	1.1	1.5
Condensate fan	Type		High-efficient axial flow fan			
	Qty	/	2	2	2	2
	Air volume	m ³ /h	7000×2	7000×2	11000×2	11600×2
	Input power	kW	0.4×2	0.4×2	0.7×2	0.9×2
Electric heating	Auxiliary heating capacity 4*	kW	9	12	15	18
Evaporator and condenser	Type		Efficient inner-grooved copper tube cover aluminum fin			
Filter	Type and level		Plate-type G3 + Plate-type F5			
Electrical parameters - Without electric heating	Max. running current	A	23.48	27.78	34.94	40.88
	Recommended power cord diameter	mm ²	6	6	10	16
Electrical parameters - With electric heating	Max. running current	A	37.12	45.96	57.67	68.15
	Recommended power cord diameter	mm ²	10	16	25	35
Unit dimension	L x W x H	mm	1870×1700×1770	1870×1700×1770	2370×2000×1970	2370×2000×2000
	Unit weight	kg	700	710	986	1042
	Noise	dB(A)	64	64	66	68

Remarks

1. Declared working condition of refrigerating capacity: OA: DB(A)=35°C, WB=28°C;
2. Declared working condition of heating capacity: OA: DB(A)=7°C; WB=6°C;
3. For all fresh air type heat pump and single cold unit, the control target is supply air temperature of unit;
4. The auxiliary heating capacity is optional; when the required auxiliary heating capacity differs from that of sample, please contact out technical staff;
5. If the performance parameters of non-standard product samples conflict with the nameplate, the nameplate parameters shall prevail.

Rooftop Air-conditioning Unit (Integral)

Clean-type All Fresh Air Heat Pump and Single Cold Unit (Performance Parameter Table 11)

Unit model			WFAJXRC70-320	WFAJXRC90-400	WFAJXRC110-500	
			WFAJXLC70-320	WFAJXLC90-400	WFAJXLC110-500	
Performance	Operating power supply		3/N/PE AC 380/220V 50Hz			
	Refrigerating capacity 1*	kW	70.2	91.5	108.4	
	Heating capacity 2*	kW	72.6	94.5	111.1	
	Unit power	kW	24.8	31.2	37.7	
	Temperature control and sensitivity 3*	°C	Refrigeration of 15-19 °C, and heating of 20-30 °C			
	Capacity control	%	0/25/50/75/100	0/25/50/75/100	0/25/50/75/100	
Compressor	Type		Hermetic scroll parallel compressor			
	Qty	/	2	2	4	
Refrigerant	Working medium used		R410A			
	Control mode		Electronic expansion valve			
	Charge Qty	kg	17	18	14×2	
Blower	Type		Centrifugal type			
	Drive mode		Belt drive			
	Air volume	m ³ /h	5600	7320	8580	
	External static pressure	Pa	320	400	500	
	Motor power	kW	2.2	3	4	
Condensate fan	Type		High-efficient axial flow fan			
	Qty	/	2	2	4	
	Air volume	m ³ /h	15000×2	18000×2	12400×4	
	Input power	kW	1.1×2	1.25×2	0.9×4	
Electric heating	Auxiliary heating capacity 4*	kW	24	30	33	
Evaporator and condenser	Type		Efficient inner-grooved copper tube cover aluminum fin			
Filter	Type and level		Plate-type G3 + Plate-type F5			
Electrical parameters - Without electric heating	Max. running current	A	50.55	64.36	83.16	
	Recommended power cord diameter	mm ²	16	25	50	
Electrical parameters - With electric heating	Max. running current	A	86.91	109.81	133.16	
	Recommended power cord diameter	mm ²	50	70	95	
Unit dimension	L x W x H	mm	2900×2300×2200	2900×2300×2200	4800×2000×2200	
	Unit weight	kg	1333	1372	1873	
	Noise	dB(A)	71	75	76	

Remarks

1. Declared working condition of refrigerating capacity: OA: DB(A)=35°C, WB=28°C;
2. Declared working condition of heating capacity: OA: DB(A)=7°C; WB=6°C;
3. For all fresh air type heat pump and single cold unit, the control target is supply air temperature of unit;
4. The auxiliary heating capacity is optional; when the required auxiliary heating capacity differs from that of sample, please contact out technical staff;
5. If the performance parameters of non-standard product samples conflict with the nameplate, the nameplate parameters shall prevail.

Rooftop Air-conditioning Unit (Integral)

Clean-type All Fresh Air Heat Pump and Single Cold Unit (Performance Parameter Table 12)

Unit model		WFAJXRC125-500	WFAJXRC140-550	WFAJXRC180-550	
		WFAJXLC125-500	WFAJXLC140-550	WFAJXLC180-550	
Performance	Operating power supply	3/N/PE AC 380/220V 50Hz			
	Refrigerating capacity 1*	kW	126	140.5	180.8
	Heating capacity 2*	kW	130.4	144.6	186
	Unit power	kW	44	48.9	64
	Temperature control and sensitivity 3*	°C	Refrigeration of 15-19 °C, and heating of 20-30 °C		
	Capacity control	%	0/25/50/75/100	0/25/50/75/100	0/25/50/75/100
Compressor	Type	Hermetic scroll parallel compressor			
	Qty	/	4	4	4
Refrigerant	Working medium used	R410A			
	Control mode	Electronic expansion valve			
	Charge Qty	kg	14×2	18×2	18×2
Blower	Type	Centrifugal type			
	Drive mode	Belt drive			
	Air volume	m³/h	10000	12500	15000
	External static pressure	Pa	500	550	550
	Motor power	kW	4	5.5	7.5
Condensate fan	Type	High-efficient axial flow fan			
	Qty	/	4	4	4
	Air volume	m³/h	11600×4	15000×4	18000×4
	Input power	kW	0.9×4	1.1×4	1.25×4
Electric heating	Auxiliary heating capacity 4*	kW	39	45	54
Evaporator and condenser	Type	Efficient inner-grooved copper tube cover aluminum fin			
Filter	Type and level	Plate-type G3 + Plate-type F5			
Electrical parameters - Without electric heating	Max. running current	A	91.96	102.40	130.72
	Recommended power cord diameter	mm²	50	50	70
Electrical parameters - With electric heating	Max. running current	A	151.05	170.58	212.54
	Recommended power cord diameter	mm²	95	120	150
Unit dimension	L x W xH	mm	4800×2000×2200	5300×2300×2400	5300×2300×2400
Unit weight	kg	1945	2375	2443	
Noise	dB(A)	76	78	78	

Remarks

1. Declared working condition of refrigerating capacity: OA: DB(A)=35°C, WB=28°C;
2. Declared working condition of heating capacity: OA: DB(A)=7°C; WB=6°C;
3. For all fresh air type heat pump and single cold unit, the control target is supply air temperature of unit;
4. The auxiliary heating capacity is optional; when the required auxiliary heating capacity differs from that of sample, please contact out technical staff;
5. If the performance parameters of non-standard product samples conflict with the nameplate, the nameplate parameters shall prevail.

Factory Dedicated Air-conditioning



1. Domestic first unit designed for factory, workshop and other large space buildings. It is designed for working conditions of open buildings, applicable to factory, workshop, station and other large space buildings; the large space air supply adopts anti-condensation spherical vent, guaranteeing far air supply distance; The spherical vent can connect with flexible air duct, so as to realize station air supply;
2. Patent structure, exterior design, and a number of technologies, fully meeting the air supply requirements in large areas. The patent self-guided air curtain anti-condensation technology realizes condensation-free operation of spherical vent and solves an industrial problem; Patent oval tube heat exchanger technology improves the comprehensive efficiency by 20%; Flow guiding and equalizing technology reduces the wind resistance and noise; Heat recovery compensation technology realizes refrigerant self-compensation of refrigeration system and increase the heating efficiency by 15%;
3. Unique installation method provides the most economical artificial environment plan for large space buildings. Patent structural design realizes the industrial-first hanging installation; Flexible installation, can realize ceiling installation; Provide the most economical artificial environment plan for large space buildings.

Product Selection

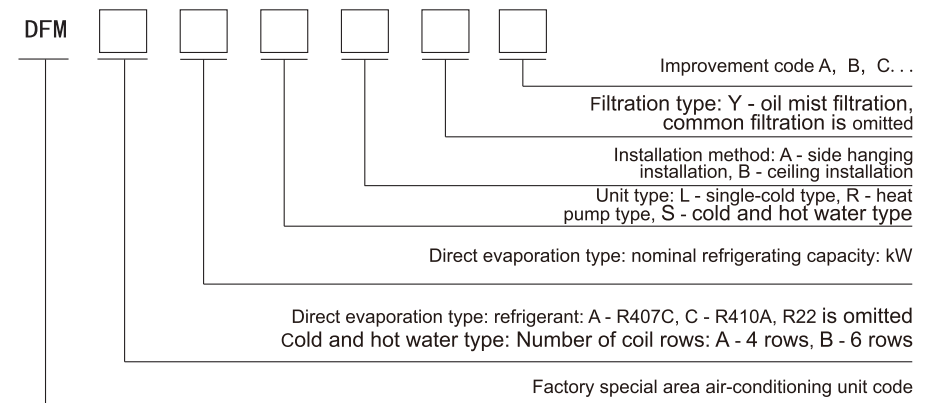

Example: For a heat pump unit with the nominal refrigerating capacity of 60kW, refrigerant of R410A, adopting side-hanging installation, direct evaporation and improved A type, the model shall be DFMC60RAA.

Ordering instructions

1. The "Technical parameter table" for direct evaporation unit specifies the refrigerating capacity and heating capacity under declared working conditions. If the working conditions are different with the declared working conditions, refer to the "performance correction coefficient for variable working conditions" for modification;
2. The direct evaporation unit is equipped with refrigerant (outdoor unit) when leaving the factory, but without copper connecting pipe, insulation pipe and cable. If needed, please specify the length in the contract;
3. For direct evaporation outdoor unit, if unit foundation shall be constructed, please refer to the instructions in unit foundation figure for construction;
4. To ensure the unit can serve you better, please specify the use place and season of unit at the time of ordering, so we can provide you with more stable and reliable control system;
5. During installation and debugging of product, technical support requirements may be proposed to company or local offices;
6. Please acknowledge that we may improve the product constantly, including its specification, performance, materials, and certification, etc., without further notice. Please contact our company to get the latest information.

Factory Dedicated Air-conditioning

Unit Technical Parameter

I. Direct Evaporation Type with Refrigerant of R410A

Performance		Unit model	DFMC28L/R*A	DFMC32L/R*A	DFMC45L/R*A	DFMC60L/R*A	DFMC70L/R*A
Air-conditioning unit performance	Refrigerating capacity	kW	28	32	45	60	70
		10 ⁴ kcal/h	2.42	2.75	3.87	5.16	6.02
	Heating capacity	kW	2.92	33.6	47	63.7	74.4
		10 ⁴ kcal/h	2.51	2.89	4.04	5.48	6.37
	Energy regulation	%	100.50.0	100.50.0	100.50.0	100.50.0	100.50.0
	Air volume	m ³ /h	3400	4000	5400	7200	8400
	Unit noise	dB(A)	62	63	64	65	65
	Power supply		3/N/PE AC 380V/220V 50Hz				
	Refrigeration input power under nominal working condition	kW	9.2	10.3	14.6	19.2	22.9
	Heating input power under nominal working condition	kW	8.8	9.6	13.8	19	22
Compressor	Type	Hermetic scroll compressor					
Refrigerant	Working medium used	R410A					
	Control form	External equalizer thermostatic expansion valve					
	Charge Qty (kg)	2X3.5	2X4	2X6	2X7	2X8	
Indoor unit	Evaporator type		Efficient red copper tube cover hydrophilic film aluminum fin				
	Fan	Type	Efficient centrifugal fan				
		Qty	1	1	2	2	2
	Filter		G3 plate-type filter screen				
	Connecting pipe	Connection type	Threaded connection		Welding		
		Liquid pipe φ (mm)	2XΦ12		2XΦ16		
		Air pipe φ (mm)	2XΦ19		2XΦ22		
	Appearance	L (mm)	2739		4586		
		W (mm)	1020		1020		
		H (mm)	652		567		
Condensate pipe		DN25		2XDN25			
Weight	kg	230	270	380	430	450	
Outdoor unit	Type		DW(R)C28SB	DW(R)C32SB	DW(R)C20SB	DW(R)C28SB	DW(R)C32SB
	Qty		1	1	2	2	2
	Condenser type		Efficient red copper tube cover aluminum fin				
	Condensate fan	Type	High-efficient axial flow fan				
		Qty	2	2	2	2	2
	Appearance	L (mm)	1592		1050		
		W (mm)	974		940		
		H (mm)	1155		1160		
	Weight	kg	210	220	2X180	2X200	2X210

Note: Declared working condition of refrigerating capacity: Air inlet dry bulb temperature of indoor unit is 30 °C, and wet bulb temperature is 24 °C; and air inlet dry bulb temperature of outdoor unit is 35 °C;
 Declared working condition of heating capacity: Air inlet dry bulb temperature of indoor unit is 18 °C; air inlet dry bulb temperature of outdoor unit is 7 °C, and wet bulb temperature is 6 °C;
 The heat pump type has heating quantity while the single cold type doesn't.
 The power supply voltage fluctuation is within ± 10% and the three-phase power supply imbalance is within 2%;
 The user shall not change the refrigerant type without permission;
 If the performance parameters conflict with the nameplate, the nameplate parameters shall prevail.
 The product design may be changed without further notice.

Factory Dedicated Air-conditioning

II. Direct Evaporation Type with Refrigerant of R22

Performance		Unit model	DFMC28L/R*A	DFMC32L/R*A	DFMC45L/R*A	DFMC60L/R*A	DFMC70L/R*A
Air-conditioning unit performance	Refrigerating capacity	kW	27.2	31.5	44.6	59.6	69.5
		10 ⁴ kcal/h	2.34	2.71	3.84	5.11	5.98
	Heating capacity	kW	28.5	32.6	46	61.8	72.4
		10 ⁴ kcal/h	2.45	2.80	3.96	5.31	6.23
	Energy regulation	%	100.50.0	100.50.0	100.50.0	100.50.0	100.50.0
	Air volume	m ³ /h	3400	4000	5400	7200	8400
	Unit noise	dB(A)	62	63	64	65	65
	Power supply		3/N/PE AC 380V/220V 50Hz				
	Refrigeration input power under nominal working condition	kW	9.6	10.8	15.5	20.2	23.8
	Heating input power under nominal working condition	kW	9.5	10.5	14.8	19.4	22.6
Compressor	Type	Hermetic scroll compressor					
Refrigerant	Working medium used	R22					
	Control form	External equalizer thermostatic expansion valve					
	Charge Qty (kg)	2X3.5	2X4	2X6	2X7	2X8	
Indoor unit	Evaporator type		Efficient red copper tube cover hydrophilic film aluminum fin				
	Fan	Type	Efficient centrifugal fan				
		Qty	1	1	2	2	2
	Filter		G3 plate-type filter screen				
	Connecting pipe	Connection type	Threaded connection		Welding		
		Liquid pipe φ (mm)	2XΦ12		2XΦ16		
		Air pipe φ (mm)	2XΦ19		2XΦ22		
	Appearance	L (mm)	2739		4586		
		W (mm)	1020		1020		
		H (mm)	652		567		
Condensate pipe		DN25		2XDN25			
Weight	kg	230	270	380	430	450	
Outdoor unit	Type		DW(R)C28SB	DW(R)C32SB	DW(R)C20B	DW(R)C28B	DW(R)C32B
	Qty		1	1	2	2	2
	Condenser type		Efficient red copper tube cover aluminum fin				
	Condensate fan	Type	High-efficient axial flow fan				
		Qty	2	2	2	2	2
	Appearance	L (mm)	1592		1050		
		W (mm)	974		940		
		H (mm)	1155		1160		
	Weight	kg	210	220	2X180	2X200	2X210

Note: Declared working condition of refrigerating capacity: Air inlet dry bulb temperature of indoor unit is 30 °C, and wet bulb temperature is 24 °C; and air inlet dry bulb temperature of outdoor unit is 35 °C;
 Declared working condition of heating capacity: Air inlet dry bulb temperature of indoor unit is 18 °C; air inlet dry bulb temperature of outdoor unit is 7 °C, and wet bulb temperature is 6 °C;
 The heat pump type has heating quantity while the single cold type doesn't.
 The power supply voltage fluctuation is within ± 10% and the three-phase power supply imbalance is within 2%;
 The user shall not change the refrigerant type without permission;
 If the performance parameters conflict with the nameplate, the nameplate parameters shall prevail.
 The product design may be changed without further notice.

Factory Dedicated Air-conditioning

III. Four Rows of Coils for Cold Water Type

Performance		Type	DFMA34S*A	DFMA40S*A	DFMA54S*A	DFMA72S*A	DFMA84S*A
Air-conditioning unit performance	Air volume	m ³ /h	3400	4000	5400	7200	8400
	Cooling capacity	kW	35	40	52	75	82
		10 ⁴ kcal/h	3.01	3.44	4.47	6.45	7.05
	Heating capacity	kW	52	60	76.5	112.5	124.6
		10 ⁴ kcal/h	4.47	5.16	6.58	9.68	10.72
	Water flow	m ³ /h	6.4	7.5	9.5	13.5	14.8
	Water resistance	kPa	19.5	23	16.5	19.5	22.5
	Power supply	3/N/PE AC 380V/220V 50Hz					
	Motor power	kW-P	1.1-4P	1.5-4P	2*0.75-4P	2*1.1-4P	2*1.5-4P
	Rated current	A	2.67	3.48	3.76	5.34	6.96
	Filter	G3 plate-type filter screen (common filtration)/oil mist filter screen + Black nylon filter screen (oil mist filtration)					
	Condensate pipe	DN25		2XDN25			
Inlet/outlet water pipe	in	1 1/2					
Noise	dB(A)	62	63	64	65	65	
Appearance	L (mm)	2739		4586	5076		
	W (mm)	1020		1020	1020		
	H (mm)	652		567	652		
Weight	kg	235	275	385	435	455	

Note: Declared working condition of cooling capacity: Air inlet dry bulb temperature of indoor unit is 30 °C, and wet bulb temperature is 24 °C; air inlet dry bulb temperature of outdoor unit is 7 °C, and air outlet temperature is 12 °C;

Declared working condition of heating capacity: Air inlet dry bulb temperature of indoor unit is 18 °C, and water inlet temperature is 60 °C;

The power supply voltage fluctuation is within ± 10% and the three-phase power supply imbalance is within 2%;

If the performance parameters conflict with the nameplate, the nameplate parameters shall prevail.

Technical parameters for six rows of coils are not listed. Because the air outlet temperature is low, it is not energy saving and not suitable for factories, stations and other large areas. If required, it can be customized according to project.

The product design may be changed without further notice.

Pharmaceutical Refrigerator Dedicated Air-conditioning



Double-wing blowing structure (patent technology). Ultra-thin compact design breaks the structural features of traditional air-conditioning and solves the warehouse installation problem;

Air curtain anti-condensation spherical vent (patent technology). The patent spherical vent solves the industrial problem of condensation at the vent, so as to meet the air supply requirements of warehouse and large areas, reduce the engineering installation, and shorten the construction period.

Oval tube heat exchange technology (patent technology) and heat recovery compensation technology (patent technology). The low wind-resistance and high-efficient oval tube heat exchanger combined with zero-loss heat recovery compensator of refrigeration system can realize fully stable and efficient operation.

Year-round refrigeration technology and dehumidification and reheat technology. The unit is equipped with year-round refrigeration technology, realizing automatic year-round humidification control.

Product Selection

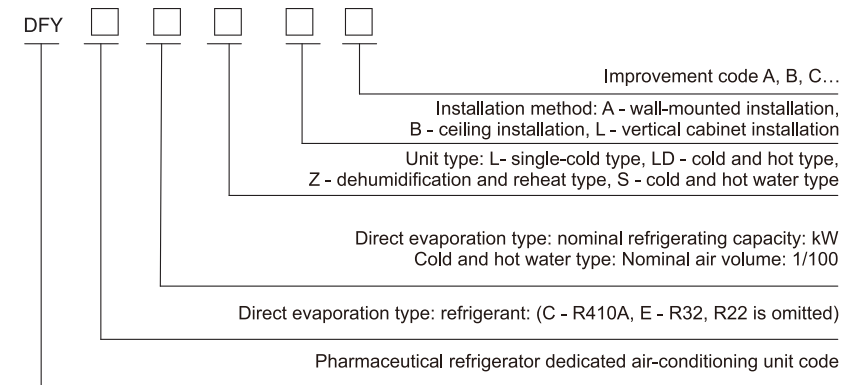

Example:

For a cold and hot type unit with the nominal refrigerating capacity of 25kW, refrigerant of R410A, adopting wall-mounted installation and direct evaporation, the model shall be DFYC25LDA; 2. For a ceiling type cold and hot water type unit with the nominal air volume of 4000m³/h, the model shall be DFY40SB.

Pharmaceutical Refrigerator Dedicated Air-conditioning

I. Direct Evaporation Type (Wall Mounted and Ceiling Unit)

Performance		Type	DFY(C)25L/LD/ZA/B	DFY(C)35L/LD/ZA/B	
Air-conditioning unit performance	Refrigerating capacity	kW	25.5	35	
		10 ⁴ kcal/h	2.19	3.01	
	Electric heating capacity/reheating capacity	kW	12	16	
		%	100.50.0	100.50.0	
	Energy regulation	%	100.50.0	100.50.0	
	Air volume	m ³ /h	6800	8400	
	Refrigerating capacity	Pa	106	112	
	Unit noise	dB(A)	65	68	
	Power supply		3/N/PE AC 380V/220V 50Hz		
	Refrigeration input power under nominal working condition	kW	10	14.2	
Compressor	Type	Hermetic scroll compressor			
Refrigerant	Working medium used	R410A /R22			
	Control form	External equalizer thermostatic expansion valve			
	Charge Qty (kg)	2X 3.5	2X4. 5		
Evaporator type		Efficient red copper tube cover hydrophilic film aluminum fin			
Fan	Type	Centrifugal fan			
	Qty	2			
Filter		G3 plate-type filter screen			
Electric heating		PTC electric heating (even distribution in two grades)			
Connecting pipe	Connection type	Threaded connection			
	Liquid pipe φ (mm)	2Xφ12			
	Air pipe φ (mm)	2Xφ19			
Appearance	L (mm)	4586	5076		
	W (mm)	1020	1020		
	H (mm)	567	652		
Condensate pipe		DN25			
Weight	kg	380	450		
Type		DW(C)28 HSB	DW(C)32 HSB		
Qty		1	1		
Condenser type		Efficient red copper tube cover aluminum fin			
Condensate fan	Type	High-efficient axial flow fan			
	Qty	2	2		
Appearance	L (mm)	1592			
	W (mm)	974			
	H (mm)	1155			
Weight	kg	210	220		

Note: Declared working condition of cooling capacity: Air inlet dry bulb temperature of indoor unit is 18 °C, and wet bulb temperature is 14 °C; and air inlet dry bulb temperature of outdoor unit is 35 °C;
 The power supply voltage fluctuation is within ± 10% and the three-phase power supply imbalance is within 2%;
 Electric heating is equipped for cold and hot type and dehumidification and reheat type unit;
 The user shall not change the refrigerant type without permission;
 If the performance parameters conflict with the nameplate, the nameplate parameters shall prevail.

Pharmaceutical Refrigerator Dedicated Air-conditioning

II. Direct Evaporation Type (Vertical Cabinet Unit)

Performance		Type	DFY(C)25L/LD/ZL	DFY(C)40L/LD/ZL	DFY(C)60L/LD/ZL	
Air-conditioning unit performance	Refrigerating capacity	kW	25.5	40	60	
		10 ⁴ kcal/h	2.19	3.44	5.16	
	Electric heating capacity/reheating capacity	kW	12	16	20	
		%	100.50.0	100.50.0	100.50.0	
	Energy regulation	%	100.50.0	100.50.0	100.50.0	
	Air volume	m ³ /h	6500	10500	17000	
	Refrigerating capacity	Pa	0/75/200/300	0/100/300/400	120/350/450	
	Unit noise	dB(A)	65	70	75	
	Power supply		3/N/PE AC 380V/220V 50Hz			
	Refrigeration input power under nominal working condition	kW	10.5	16.5	24.8	
Compressor	Type	Hermetic scroll compressor				
Refrigerant	Working medium used	R410A/R22				
	Control form	External equalizer thermostatic expansion valve				
	Charge Qty (kg)	2X 3.5	2X 6	2X 8		
Evaporator type		Efficient red copper tube cover hydrophilic film aluminum fin				
Fan	Type	Centrifugal fan				
	Qty	1				
Filter		Black nylon filter screen				
Electric heating		PTC electric heating (even distribution in two grades)				
Connecting pipe	Connection type	Threaded connection	Welding			
	Liquid pipe φ (mm)	2Xφ12	2Xφ16	2Xφ16		
	Air pipe φ (mm)	2Xφ19	2Xφ22	2Xφ28		
Appearance	L (mm)	1340	1750	2160		
	W (mm)	630	860	1020		
	H (mm)	1880(2200)	1880(2200)	1920		
Condensate pipe		DN25				
Weight	kg	300(320)	450(480)	700		
Type		DW(C)28HSB	DW(C)20HB	DW(C)32HB		
Qty		1	2	2		
Condenser type		Efficient red copper tube cover aluminum fin				
Condensate fan	Type	High-efficient axial flow fan				
	Qty	2	2	2		
Appearance	L (mm)	1592	1050			
	W (mm)	974	940			
	H (mm)	1155	1160			
Weight	kg	210	2 X140	2X170		

Note: Declared working condition of cooling capacity: Air inlet dry bulb temperature of indoor unit is 18 °C, and wet bulb temperature is 14 °C; and air inlet dry bulb temperature of outdoor unit is 35 °C;
 The power supply voltage fluctuation is within ± 10% and the three-phase power supply imbalance is within 2%;
 Electric heating is equipped for cold and hot type and dehumidification and reheat type unit;
 The noise value is that of medium static pressure for unit with air duct, so does the refrigeration consumption power;
 (** in height of dimension is height of direct air-out type unit.
 The user shall not change the refrigerant type without permission;
 If the performance parameters conflict with the nameplate, the nameplate parameters shall prevail.

Condensing Exhaust and Heat Recovery of Fresh Air All-in-one Machine

A. Horizontal type condensing exhaust and heat recovery of fresh air all-in-one machine (indoor type)

Equipment		Fixed frequency	WFBXRC25WI-500/500	WFBXRC30WI-500/500	WFBXRC40WI-500/500
		Variable frequency	WFBXRC25WIV-500/500	WFBXRC30WIV-500/500	WFBXRC40WIV-500/500
Power supply		V-Ph-Hz	380-3-50	380-3-50	380-3-50
Fresh air volume		m ³ /h	3000	4000	5000
Air exhaust volume		m ³ /h	3000 (return) + 2100 (fresh)	4000 (return) + 2800 (fresh)	5000 (return) + 3500 (fresh)
Refrigeration capacity 1*		kW	27.0	30.6	40.5
Input power under rated refrigeration working condition		kW	9.7	10.9	14.5
Heating capacity 2*		kW	27.2	31.0	41.5
Input power under rated heating working condition		kW	8.4	9.5	12.8
Protection device			High-voltage switch, low-voltage switch, compressor overheating, power, exhaust overheating, compressor over-current protection, fan motor over-current, etc.		
Capacity control		Fixed frequency %	100/75/50/25/0	100/75/50/25/0	100/75/50/25/0
		Variable frequency %	100 ~ 25/0	100 ~ 25/0	100 ~ 15/0
Refrigerant	Type		R410A		
	Control mode		Electronic expansion valve		
Compressor	Rated input power	kW	6.85	7.7	10.2
	COP 3*	Refrigeration	3.94	3.97	3.97
		Heating	4.88	4.92	4.90
Condenser	Type		Efficient circular tube heat exchanger		
	Rated power of exhaust fan motor	kW	2.2	4	4
	External static pressure	Pa	500	500	500
Evaporator	Evaporator		Efficient oval tube heat exchanger		
	Rated power of blower moto	kW	1.5	2.2	2.2
	External static pressure	Pa	500	500	500
Filter 4*			G3	G3	G3
Drain pipe			DN25	DN25	DN25
Noise 5*		dB(A)	60	62	63
Housing			Aluminum-zinc coated plate	Aluminum-zinc coated plate	Aluminum-zinc coated plate
Overall dimension	L x W x H	mm	2700 x 1000 x 2200	2700 x 1000 x 2200	2700 x 1160 x 2200
Unit weight		kg	1050	1180	1350

Note:

1. Declared working condition of refrigerating capacity: OA: DB=35°C, WB=28°C; RA: DB=27°C, WB=19°C;
2. Declared working condition of heating capacity: OA: DB=7°C, WB=6°C; RA: DB=20°C, WB=15°C;
3. COP capacity doesn't include fan power, because different external static pressures can also cause change of power;
4. Plate-type medium efficiency filter is optional;
5. The noise value is measured inside the noise room;
6. Wet-film humidifier, condensation reheat coils and other auxiliary heaters are optional;
7. If the performance parameters conflict with the nameplate, the nameplate parameters shall prevail;
8. The product design may be changed without further notice.

Condensing Exhaust and Heat Recovery of Fresh Air All-in-one Machine

Equipment		Fixed frequency	WFBXRC50WI-500/500	WFBXRC60WI-500/500	WFBXRC80WI-500/500
		Variable frequency	WFBXRC50WIV-500/500	WFBXRC60WIV-500/500	WFBXRC80WIV-500/500
Power supply		V-Ph-Hz	380-3-50	380-3-50	380-3-50
Fresh air volume		m ³ /h	6000	7000	10000
Air exhaust volume		m ³ /h	6000 (return) + 4200 (fresh)	7000 (return) + 5000 (fresh)	10000 (return) + 7000 (fresh)
Refrigeration capacity 1*		kW	54.0	61.1	80.9
Input power under rated refrigeration working condition		kW	19.3	21.9	29.9
Heating capacity 2*		kW	54.3	61.8	82.4
Input power under rated heating working condition		kW	16.7	19.1	26.3
Protection device			High-voltage switch, low-voltage switch, compressor overheating, power, exhaust overheating, compressor over-current, fan motor over-current, etc.		
Capacity control		Fixed frequency %	100/75/50/25/0	100/75/50/25/0	100/75/50/25/0
		Variable frequency %	100 ~ 15/0	100 ~ 15/0	100 ~ 15/0
Refrigerant	Type		R410A		
	Control mode		Electronic expansion valve		
Compressor	Rated input power	kW	13.7	15.4	20.4
	COP 3	Refrigeration	3.94	3.97	3.97
		Heating	4.86	4.92	4.92
Condenser	Type		Efficient circular tube heat exchanger		
	Rated power of exhaust fan motor	kW	5.5	5.5	11
	External static pressure	Pa	500	500	500
Evaporator	Evaporator		Efficient oval tube heat exchanger		
	Rated power of blower moto	kW	3	3	5.5
	External static pressure	Pa	500	500	500
Filter 4*			G3	G3	G3
Drain pipe			DN25	DN25	DN32
Noise 5*		dB(A)	65	66	68
Housing			Aluminum-zinc coated plate	Aluminum-zinc coated plate	Aluminum-zinc coated plate
Overall dimension	L x W x H	mm	2700 x 1510 x 2200	2700 x 1510 x 2200	2810 x 1760 x 2200
Unit weight		kg	1600	1700	2080

Note:

1. Declared working condition of refrigerating capacity: OA: DB=35°C, WB=28°C; RA: DB=27°C, WB=19°C;
2. Declared working condition of heating capacity: OA: DB=7°C, WB=6°C; RA: DB=20°C, WB=15°C;
3. COP capacity doesn't include fan power, because different external static pressures can also cause change of power;
4. Plate-type medium efficiency filter is optional;
5. The noise value is measured inside the noise room;
6. Wet-film humidifier, condensation reheat coils and other auxiliary heaters are optional;
7. If the performance parameters conflict with the nameplate, the nameplate parameters shall prevail;
8. The product design may be changed without further notice.

Condensing Exhaust and Heat Recovery of Fresh Air All-in-one Machine

Equipment	Fixed frequency	WFBXRC100WI-500/500	WFBXRC120WI-500/500	
	Variable frequency	WFBXRC100WIV-500/500	WFBXRC120WIV-500/500	
Power supply	V-Ph-Hz	380-3-50	380-3-50	
Fresh air volume	m ³ /h	12000	15000	
Air exhaust volume	m ³ /h	12000 (return) + 8400 (fresh)	15000 (return) + 10500 (fresh)	
Refrigeration capacity 1*	kW	97.7	121.4	
Input power under rated refrigeration working condition	kW	36.1	44.9	
Heating capacity 2*	kW	98.8	122.8	
Input power under rated heating working condition	kW	31.7	39.4	
Protection device		High-voltage switch, low-voltage switch, compressor overheating , power , exhaust overheating , compressor over-current , fan motor over-current , etc.		
Capacity control	Fixed frequency %	100/83.3/66.7/50/33.3/16.7/0	100/83.3/66.7/50/33.3/16.7/0	
	Variable frequency %	100 ~ 10/0	100 ~ 10/0	
Refrigerant	Type	R410A		
	Control mode	Electronic expansion valve		
Compressor	Rated input power	kW	24.6	30.6
	COP 3*	Refrigeration	3.97	3.97
		Heating	4.84	4.88
Condenser	Type	Efficient circular tube heat exchanger		
	Rated power of exhaust fan motor	kW	15	15
	External static pressure	Pa	500	500
Evaporator	Evaporator	Efficient oval tube heat exchanger		
	Rated power of blower moto	kW	7.5	7.5
	External static pressure	Pa	500	500
Filter 4*		G3	G3	
Drain pipe		DN32	DN32	
Noise 5*	dB(A)	69	72	
Housing		Aluminum-zinc coated plate	Aluminum-zinc coated plate	
Overall dimension	L x W x H	mm	3030×2110×2200	3030×2610×2200
Unit weight	kg	2460	2930	

Note:

1. Declared working condition of refrigerating capacity: OA: DB=35°C, WB=28°C; RA: DB=27°C, WB=19°C;
2. Declared working condition of heating capacity: OA: DB=7°C, WB=6°C; RA: DB=20°C, WB=15°C;
3. COP capacity doesn't include fan power, because different external static pressures can also cause change of power;
4. Plate-type medium efficiency filter is optional;
5. The noise value is measured inside the noise room;
6. Wet-film humidifier, condensation reheat coils and other auxiliary heaters are optional;
7. If the performance parameters conflict with the nameplate, the nameplate parameters shall prevail;
8. The product design may be changed without further notice.

Condensing Exhaust and Heat Recovery of Fresh Air All-in-one Machine

B. Horizontal type condensing exhaust and heat recovery of fresh air all-in-one machine (outdoor type)

Equipment	Fixed frequency	WFBXRC25WO-500/500	WFBXRC30WO-500/500	WFBXRC40WO-500/500	
	Variable frequency	WFBXRC25WOV-500/500	WFBXRC30WOV-500/500	WFBXRC40WOV-500/500	
Power supply	V-Ph-Hz	380-3-50	380-3-50	380-3-50	
Fresh air volume	m ³ /h	3000	4000	5000	
Air exhaust volume	m ³ /h	3000 (return) +2100 (fresh)	4000 (return) + 2800 (fresh)	5000 (return) + 3500 (fresh)	
Refrigeration capacity 1*	kW	27.0	30.6	40.5	
Input power under rated refrigeration working condition	kW	9.7	10.9	14.5	
Heating capacity 2*	kW	27.2	31.0	41.5	
Input power under rated heating working condition	kW	8.4	9.5	12.8	
Protection device		High-voltage switch, low-voltage switch, compressor overheating , power , exhaust overheating , compressor over-current , fan motor over-current , etc.			
Capacity control	Fixed frequency %	100/75/50/25/0	100/75/50/25/0	100/75/50/25/0	
	Variable frequency %	100 ~ 25/0	100 ~ 25/0	100 ~ 15/0	
Refrigerant	Type	R410A			
	Control mode	Electronic expansion valve			
Compressor	Rated input power	kW	6.85	7.7	10.2
	COP 3*	Refrigeration	3.94	3.97	3.97
		Heating	4.88	4.92	4.90
Condenser	Type	Efficient circular tube heat exchanger			
	Rated power of exhaust fan motor	kW	2.2	4	4
	External static pressure	Pa	500	500	500
Evaporator	Evaporator	Efficient oval tube heat exchanger			
	Rated power of blower moto	kW	1.5	2.2	2.2
	External static pressure	Pa	500	500	500
Filter 4*		G3	G3	G3	
Drain pipe		DN25	DN25	DN25	
Noise 5*	dB(A)	60	62	63	
Housing		Aluminum-zinc coated plate	Aluminum-zinc coated plate	Aluminum-zinc coated plate	
Overall dimension	L x W x H	mm	2700×1000×2200	2700×1000×2200	2700×1160×2200
Unit weight	kg	1230	1400	1520	

Note:

1. Declared working condition of refrigerating capacity: OA: DB=35°C, WB=28°C; RA: DB=27°C, WB=19°C;
2. Declared working condition of heating capacity: OA: DB=7°C, WB=6°C; RA: DB=20°C, WB=15°C;
3. COP capacity doesn't include fan power, because different external static pressures can also cause change of power;
4. Plate-type medium efficiency filter is optional;
5. The noise value is measured inside the noise room;
6. Wet-film humidifier, condensation reheat coils and other auxiliary heaters are optional;
7. If the performance parameters conflict with the nameplate, the nameplate parameters shall prevail;
8. The product design may be changed without further notice.

Condensing Exhaust and Heat Recovery of Fresh Air All-in-one Machine

Equipment	Fixed frequency	WFBXRC50WO-500/500	WFBXRC60WO-500/500	WFBXRC80WO-500/500	
	Variable frequency	WFBXRC50WOV-500/500	WFBXRC60WOV-500/500	WFBXRC80WOV-500/500	
Power supply	V-Ph-Hz	380-3-50	380-3-50	380-3-50	
Fresh air volume	m ³ /h	6000	7000	10000	
Air exhaust volume	m ³ /h	6000 (return) + 4200 (fresh)	7000 (return) + 5000 (fresh)	10000 (return) + 7000 (fresh)	
Refrigeration capacity 1*	kW	54.0	61.1	80.9	
Input power under rated refrigeration working condition	kW	19.3	21.9	29.9	
Heating capacity 2*	kW	54.3	61.8	82.4	
Input power under rated heating working condition	kW	16.7	19.1	26.3	
Protection device		High-voltage switch, low-voltage switch, compressor overheating , power , exhaust overheating , compressor over-current , fan motor over-current , etc.			
Capacity control	Fixed frequency %	100/75/50/25/0	100/75/50/25/0	100/75/50/25/0	
	Variable frequency %	100 ~ 15/0	100 ~ 15/0	100 ~ 15/0	
Refrigerant	Type	R410A			
	Control mode	Electronic expansion valve			
Compressor	Rated input power	kW	13.7	15.4	20.4
	COP 3*	Refrigeration	3.94	3.97	3.97
		Heating	4.86	4.92	4.92
Condenser	Type	Efficient circular tube heat exchanger			
	Rated power of exhaust fan motor	kW	5.5	5.5	11
	External static pressure	Pa	500	500	500
Evaporator	Evaporator	Efficient oval tube heat exchanger			
	Rated power of blower moto	kW	3	3	5.5
	External static pressure	Pa	500	500	500
Filter 4*		G3	G3	G3	
Drain pipe		DN25	DN25	DN32	
Noise 5*	dB(A)	65	66	68	
Housing		Aluminum-zinc coated plate	Aluminum-zinc coated plate	Aluminum-zinc coated plate	
Overall dimension	L x W x H	mm	2700×1510×2200	2700×1510×2200	2810×1760×2200
Unit weight	kg	1800	1900	2300	

Note:

1. Declared working condition of refrigerating capacity: OA: DB=35°C, WB=28°C; RA: DB=27°C, WB=19°C;
2. Declared working condition of heating capacity: OA: DB=7°C, WB=6°C; RA: DB=20°C, WB=15°C;
3. COP capacity doesn't include fan power, because different external static pressures can also cause change of power;
4. Plate-type medium efficiency filter is optional;
5. The noise value is measured inside the noise room;
6. Wet-film humidifier, condensation reheat coils and other auxiliary heaters are optional;
7. If the performance parameters conflict with the nameplate, the nameplate parameters shall prevail;
8. The product design may be changed without further notice.

Condensing Exhaust and Heat Recovery of Fresh Air All-in-one Machine

Equipment	Fixed frequency	WFBXRC100WO-500/500	WFBXRC120WO-500/500	
	Variable frequency	WFBXRC100WOV-500/500	WFBXRC120WOV-500/500	
Power supply	V-Ph-Hz	380-3-50	380-3-50	
Fresh air volume	m ³ /h	12000	15000	
Air exhaust volume	m ³ /h	12000 (return) + 8400 (fresh)	15000 (return) + 10500 (fresh)	
Refrigeration capacity 1*	kW	97.7	121.4	
Input power under rated refrigeration working condition	kW	36.1	44.9	
Heating capacity 2*	kW	98.8	122.8	
Input power under rated heating working condition	kW	31.7	39.4	
Protection device		High-voltage switch, low-voltage switch, compressor overheating protection, power protection, exhaust overheating protection, compressor over-current protection, fan motor over-current protection, etc.		
Capacity control	Fixed frequency %	100/83.3/66.7/50/33.3/16.7/0	100/83.3/66.7/50/33.3/16.7/0	
	Variable frequency %	100 ~ 10/0	100 ~ 10/0	
Refrigerant	Type	R410A		
	Control mode	Electronic expansion valve		
Compressor	Rated input power	kW	24.6	30.6
	COP 3*	Refrigeration	3.97	3.97
		Heating	4.84	4.88
Condenser	Type	Efficient circular tube heat exchanger		
	Rated power of exhaust fan motor	kW	15	15
	External static pressure	Pa	500	500
Evaporator	Evaporator	Efficient oval tube heat exchanger		
	Rated power of blower moto	kW	7.5	7.5
	External static pressure	Pa	500	500
Filter 4*		G3	G3	
Drain pipe		DN32	DN32	
Noise 5*	dB(A)	69	72	
Housing		Aluminum-zinc coated plate	Aluminum-zinc coated plate	
Overall dimension	L x W x H	mm	3030×2110×2200	3030×2610×2200
Unit weight	kg	2750	3260	

Note:

1. Declared working condition of refrigerating capacity: OA: DB=35°C, WB=28°C; RA: DB=27°C, WB=19°C;
2. Declared working condition of heating capacity: OA: DB=7°C, WB=6°C; RA: DB=20°C, WB=15°C;
3. COP capacity doesn't include fan power, because different external static pressures can also cause change of power;
4. Plate-type medium efficiency filter is optional;
5. The noise value is measured inside the noise room;
6. Wet-film humidifier, condensation reheat coils and other auxiliary heaters are optional;
7. If the performance parameters conflict with the nameplate, the nameplate parameters shall prevail;
8. The product design may be changed without further notice.

Multi-split Air-conditioning (Heat Pump) Unit



Unit Feature

1. By using large-capacity high-pressure cavity DC inverter scroll compressor, efficient Brushless DC fan motor, integrated efficient U-type heat exchanger, efficient and stable refrigerant piping design, and dual-wheel conversion and dual-backup technologies, these can realize the industrial leading IPLV, 7.55 maximally and 7.07 on average;
2. Six oil-return control technology, being precise and reliable; nine comprehensive noise control technology, guaranteeing quiet operation;
3. Quick start of heating, quick intelligent defrosting and wind and snow resistance function, etc. can realize strong winter heating effect;
4. Intelligent control, multiple operation modes for selection and advanced control board can realize humanized management.

Unit Model Denotation Method

Multi-split air-conditioning unit - outdoor

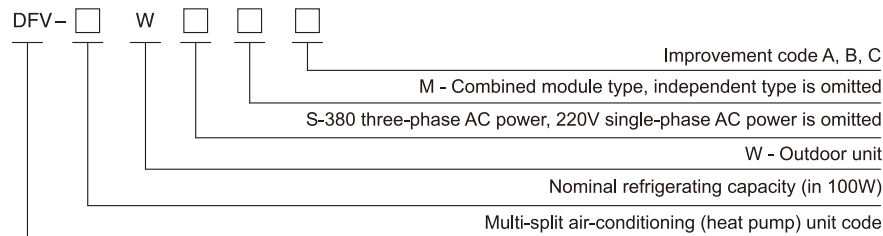

Multi-split air-conditioning unit - indoor

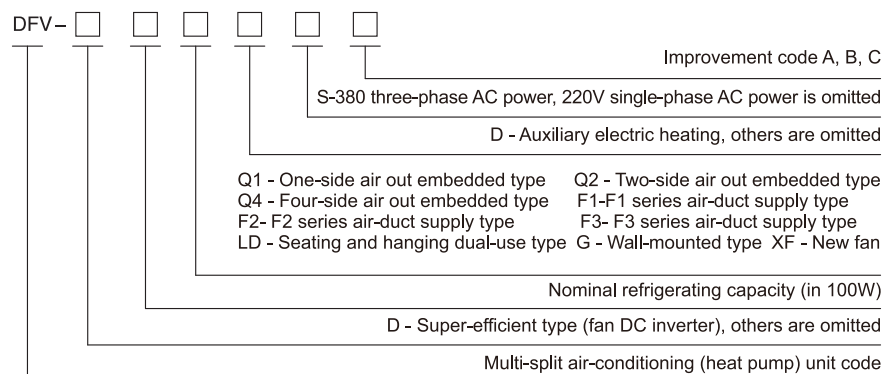

Multi-split Air-conditioning (Heat Pump) Unit

Indoor Unit Parameter Table

Four-side Air Out Embedded Type

Four-side air out embedded type (energy saving)														
Indoor unit model	DFV-28Q4(D)	DFV-36Q4(D)	DFV-45Q4(D)	DFV-50Q4(D)	DFV-56Q4(D)	DFV-63Q4(D)	DFV-71Q4(D)	DFV-80Q4(D)	DFV-90Q4(DS)	DFV-100Q4(DS)	DFV-112Q4(DS)	DFV-125Q4(DS)	DFV-140Q4(DS)	
Indoor unit power	AC220V/50Hz/φ								AC220V/50Hz/1φ (AC380V/50Hz/3φ)					
Rated refrigerating capacity	kw	2.8	3.6	4.5	5.0	5.6	6.3	7.1	8.0	9.0	10.0	11.2	12.5	14.0
Rated heating capacity	kw	3.2(4.7)	4.0(5.5)	5.0(6.5)	5.6(7.1)	6.3(7.8)	7.1(9.1)	8.0(10.0)	8.8(10.8)	10.0(13)	11.0(1)	12.5(1)	14.0(1)	15.0(1)
Auxiliary electric heating	kw	(4.7)	1.5			2.0			0	4.0	3.5	7.0	8.0	
Rated power	kw	0.043(1.543)	0.054(1.554)			0.093(2.093)			0.160(3.160)					
Noise value	dB(A)	32~36		35~39			36~39			37~41				
Standard air volume	m³/h	650		810			1200			1600				
Unit dimension	mm	900×833×232							900×833×286					
Panel dimension	mm	950×950×50												
Unit weight	kg	22	24(25)			22.5(23.5)			27(28.5)					
Panel weight	kg	(23)			5.4									
Refrigerant connecting pipe		Horn-shaped flared connection												
Air pipe	mm	φ9.52	φ12.7			φ15.88								
Liquid pipe	mm	φ6.35			φ9.52									
Drain pipe	mm	DN25												

Four-side air out embedded type (energy saving)														
Indoor unit model	DFV-D28Q4(D)	DFV-D36Q4(D)	DFV-D45Q4(D)	DFV-D50Q4(D)	DFV-D56Q4(D)	DFV-D63Q4(D)	DFV-D71Q4(D)	DFV-D80Q4(D)	DFV-D90Q4(DS)	DFV-D100Q4(DS)	DFV-D112Q4(DS)	DFV-D125Q4(DS)	DFV-D140Q4(DS)	
Indoor unit power	AC220V/50Hz/1φ								AC220V/50Hz/1φ (AC380V/50Hz/3φ)					
Rated refrigerating capacity	kw	2.8	3.6	4.5	5.0	5.6	6.3	7.1	8.0	9.0	10.0	11.2	12.5	14.0
Rated heating capacity	kw	3.2	4.0(5.5)	5.0(6.5)	5.6(7.1)	6.3(7.8)	7.1(9.1)	8.0(10.0)	8.8(10.8)	10.0(13)	11.0(1)	12.5(1)	14.0(1)	15.0(1)
Auxiliary electric heating	kw	(4.7)	1.5			2.0			0	4.0	3.5	7.0	8.0	
Rated power	kw	0.02(1.5)	0.03(1.53)			0.07(2.07)			0.1(3.1)					
Noise value	dB(A)	32~36		35~39			36~39			37~41				
Standard air volume	m³/h	650		810			1200			1600				
Unit dimension	mm	900×833×232							900×833×286					
Panel dimension	mm	950×950×50												
Unit weight	kg	20.5(21.5)	22(23)			22.5(23.5)			27(28.5)					
Panel weight	kg	5.4												
Refrigerant connecting pipe		Horn-shaped flared connection												
Air pipe	mm	φ9.52	φ12.7			φ15.88								
Liquid pipe	mm	φ6.35			φ9.52									
Drain pipe	mm	DN25												

Multi-split Air-conditioning (Heat Pump) Unit

F1 Series Air-duct Supply Type

F1 series air-duct supply type (energy saving)												
Indoor unit model	DFV-22F1(D)	DFV-25F1(D)	DFV-28F1(D)	DFV-32F1(D)	DFV-36F1(D)	DFV-40F1(D)	DFV-45F1(D)	DFV-50F1(D)	DFV-56F1(D)	DFV-63F1(D)	DFV-71F1(D)	
Indoor unit power	AC 220V/50HZ/1 φ											
Rated refrigerating capacity	kw	2.2	2.5	2.8	3.2	3.6	4.0	4.5	5.0	5.6	6.3	7.1
Rated heating capacity	kw	2.5(3.25)	2.8(3.55)	3.2(3.95)	3.5(4.25)	4.0(4.75)	4.5(5.25)	5.0(5.75)	5.6(6.8)	6.3(7.5)	7.1(8.6)	8.0(9.5)
Auxiliary electric heating	kw	0.75						1.2		1.5		
Rated power	kw	0.05(0.80)		0.07(0.82)		0.075(0.825)		0.10(1.30)		0.11(1.61)		
Noise value	dB(A)	24~29		25~32		32~37		28~38		30~39		
Standard air volume	m ³ /h	450		550		620		800		1000		
Max. static pressure	pa	30										
Overall dimension	mm	814×467×210					1010×467×210			1214×467×210		
Air outlet size	mm	503×150				705×150			905×150			
Return air inlet size	mm	611×200					811×200			1011×200		
Refrigerant connecting pipe	Horn-shaped flared connection											
Air pipe	mm	φ9.52			φ12.7				φ15.88			
Liquid pipe	mm	φ6.35						φ9.52				
Drain pipe	mm	DN25										
Net weight (gross weight)	kg	16(16.5)			16.5(17)			21(21.5)		25.5(26)		

F1 series air-duct supply type (super-efficient)												
Indoor unit model	DFV-D22F1(D)	DFV-D25F1(D)	DFV-D28F1(D)	DFV-D32F1(D)	DFV-D36F1(D)	DFV-D40F1(D)	DFV-D45F1(D)	DFV-D50F1(D)	DFV-D56F1(D)	DFV-D63F1(D)	DFV-D71F1(D)	
Indoor unit power	AC 220V/50HZ/1 φ											
Rated refrigerating capacity	kw	2.2	2.5	2.8	3.2	3.6	4.0	4.5	5.0	5.6	6.3	7.1
Rated heating capacity	kw	2.5(3.25)	2.8(3.55)	3.2(3.95)	3.5(4.25)	4.0(4.75)	4.5(5.25)	5.0(5.75)	5.6(6.8)	6.3(7.5)	7.1(8.6)	8.0(9.5)
Auxiliary electric heating	kw	0.75						1.2		1.5		
Rated power	kw	0.02(0.77)		0.03(0.78)		0.035(0.785)		0.045(1.245)		0.055(1.555)		
Noise value	dB(A)	24~29		25~32		32~37		28~38		30~39		
Standard air volume	m ³ /h	450		500		620		800		1000		
Max. static pressure	pa	30										
Overall dimension	mm	814×467×210					1010×467×210			1214×467×210		
Air outlet size	mm	503×150				705×150			905×150			
Return air inlet size	mm	611×200					811×200			1011×200		
Refrigerant connecting pipe	Horn-shaped flared connection											
Air pipe	mm	φ 9.52			φ 12.7				φ 15.88			
Liquid pipe	mm	φ 6.35						φ 9.52				
Drain pipe	mm	DN25										
Net weight (gross weight)	kg	16(16.5)			16.5(17)			20(20.5)		25(25.5)		

Multi-split Air-conditioning (Heat Pump) Unit

F2 Medium-static Pressure Air Duct

F2 series air-duct supply type (energy saving)										
Indoor unit model	DFV-71F2(D)	DFV-80F2(D)	DFV-90F2(D)	DFV-100F2(D)	DFV-112F2(D)	DFV-125F2(D)	DFV-140F2(D)	DFV-150F2(D)		
Indoor unit power	AC 220V/50HZ/1 φ									
Rated refrigerating capacity	kw	7.1	8.0	9.0	10.0	11.2	12.5	14.0	15.0	
Rated heating capacity	kw	8.0(10.1)	9.0(11.1)	10.0(12.1)	11.0(13.1)	12.5(14.6)	14.0(16.1)	16.0(18.1)	17.0(19.1)	
Auxiliary electric heating	kw	2.1								
Rated power	kw	0.13(2.23)			0.24(2.34)					
Noise value	dB(A)	29~39			36~43					
Standard air volume	m ³ /h	1050			1800					
Max. static pressure	pa	30								
Overall dimension	mm	1209×680×260			1445×680×260					
Air outlet size	mm	920×197			1156×197					
Return air inlet size	mm	920×207			1156×207					
Refrigerant connecting pipe	Horn-shaped flared connection									
Air pipe	mm	φ15.88								
Liquid pipe	mm	φ9.52								
Drain pipe	mm	DN25								
Net weight	kg	35(36)			45(46)					

F2 series air-duct supply type (super-efficient)										
Indoor unit model	DFV-D71F2(D)	DFV-D80F2(D)	DFV-D90F2(D)	DFV-D100F2(D)	DFV-D112F2(D)	DFV-D125F2(D)	DFV-D140F2(D)	DFV-D150F2(D)		
Indoor unit power	AC 220V/50HZ/1 φ									
Rated refrigerating capacity	kw	7.1	8.0	9.0	10.0	11.2	12.5	14.0	15.0	
Rated heating capacity	kw	8.0(10.1)	9.0(11.1)	10.0(12.1)	11.0(13.1)	12.5(14.6)	14.0(16.1)	16.0(18.1)	17.0(19.1)	
Auxiliary electric heating	kw	2.1								
Rated power	kw	0.09(2.19)			0.1(2.2)					
Noise value	dB(A)	29~39			36~43					
Standard air volume	m ³ /h	1050			1800					
Max. static pressure	pa	30								
Overall dimension	mm	1209×680×260			1445×680×260					
Air outlet size	mm	920×197			1156×197					
Return air inlet size	mm	920×207			1156×207					
Refrigerant connecting pipe	Horn-shaped flared connection									
Air pipe	mm	φ15.88								
Liquid pipe	mm	φ9.52								
Drain pipe	mm	DN25								
Net weight	kg	35(36)			45(46)					

Multi-split Air-conditioning (Heat Pump) Unit

F3 Series Air-duct Supply Type

F3 series air-duct supply type																
Indoor unit model	DFV-71F3 (D)	DFV-80F3 (D)	DFV-90F3 (D)	DFV-100F3 (D)	DFV-112F3 (D)	DFV-125F3 (D)	DFV-140F3 (D)	DFV-150F3 (D)	DFV-160F3 (D)	DFV-200F3	DFV-250F3	DFV-280F3	DFV-450F3S	DFV-560F3S		
Indoor unit power	AC 220V/50HZ/1 φ			AC 220V/50HZ/1 φ (AC380V/50HZ/3 φ)						AC 220V/50HZ/1 φ			AC 380V/50HZ/3 φ			
Rated refrigerating capacity	kw	7.1	8.0	9.0	10.0	11.2	12.5	14.0	15.0	16.0	20.0	25.0	28.0	45.0	56.0	
Rated heating capacity	kw	7.8 (9.9)	8.8 (10.9)	10.0 (12.1)	11.0 (14.0)	12.5 (15.5)	14.0 (17.0)	16.0 (19.0)	17.0 (20.0)	18.0 (21.0)	22.0	27.5	31.8	50.0	63.0	
Auxiliary electric heating	kw	2.1			3.0						/					
Rated power	kw	0.34(2.44)			0.45(3.45)						1.20			1.60	2.45	
Noise value	dB(A)	40~42			44~52						45~55			60	64	
Standard air volume	m ³ /h	1500			2300						4400			6000	8000	
Max static pressure	pa				120						200					
Overall dimension	mm	1445×680×260			1190×620×370						1465×811×448			2165×916×676		
Air outlet size	mm	1156×197			740×267						930×180			928×292		
Return air inlet size	mm	1156×207			920×290						1174×272			1563×563		
Refrigerant connecting pipe	Horn-shaped flared connection															
Air pipe	mm	φ15.88			φ22.2						φ28.6					
Liquid pipe	mm	φ9.52			φ12.7						φ15.88					
Drain pipe	mm	DN25			DN30						DN32					
Net weight	kg	46(47)			47(49)						102(113)			222(260)		

One-side Air Out Embedded Type

One-side air out embedded type					
Indoor unit model		DFV-22Q1	DFV-28Q1	DFV-36Q1	DFV-45Q1
Refrigerating capacity	KW	2.2	2.8	3.6	4.5
Heating capacity	KW	2.5	3.2	4	5
Power supply specification	V-HZ	200-50	200-50	200-50	200-50
Power consumption	KW	0.04	0.04	0.04	0.05
Standard air volume	m ³ /h	520	520	520	610
Noise value	dB(A)	30 ~ 36	30 ~ 36	30 ~ 36	30 ~ 41
Unit dimension	mm	994x532x250	994x532x250	994x532x250	994x532x250
Panel dimension	mm	1070x520x50	1070x520x50	1070x520x50	1070x520x50
Unit weight	kg	24	24	24	24
Panel weight	kg	3.6	3.6	3.6	3.6
Air pipe specification	mm	φ 9.52	φ 9.52	φ 9.52	φ 12.7
Fluid pipe specification	mm	φ 6.35	φ 6.35	φ 6.35	φ 6.35
Drain pipe specification	mm	DN20	DN20	DN20	DN20

Multi-split Air-conditioning (Heat Pump) Unit

Two-side Air Out Embedded Type

Two-side air out embedded type				
Indoor unit model		DFV-45Q2	DFV-56Q2	DFV-71Q2
Refrigerating capacity	KW	4.5	5.6	7.1
Heating capacity	KW	5.0	6.3	8.0
Power supply specification	V-HZ	200-50	200-50	200-50
Power consumption	KW	0.07	0.07	0.10
Standard air volume	m ³ /h	800	800	1120
Noise value	dB(A)	36 ~ 42	36 ~ 42	40 ~ 46
Unit dimension	mm	1068x517x310	1068x517x310	1308x517x310
Panel dimension	mm	1205x630x50	1205x630x50	1445x630x50
Unit weight	kg	33	33	40
Panel weight	kg	6.5	6.5	7.5
Air pipe specification	mm	φ 12.7	φ 12.7	φ 15.88
Fluid pipe specification	mm	φ 6.35	φ 6.35	φ 9.52
Drain pipe specification	mm	DN20	DN20	DN20

Seating And Hanging Dual-use Type

Seating and hanging dual-use type						
Indoor unit model		DFV-45LD	DFV-56LD	DFV-71LD	DFV-80LD	DFV-112LD
Indoor unit power		AC 220V/50HZ/1 φ				
Rated refrigerating capacity	kw	4.5	5.6	7.1	8.0	11.2
Rated heating capacity	kw	5.0	6.3	8.0	8.8	12.5
Auxiliary electric heating	kw	/				
Rated power	kw	0.06		0.15		0.26
Noise value	dB(A)	37~46		39~48		45~52
Standard air volume	m ³ /h	950		1300		2300
Unit dimension	mm	1245 × 680 × 240				1670 × 680 × 240
Weight	kg	36				51
Refrigerant connecting pipe	Horn-shaped flared connection					
Air pipe	mm	φ 12.7		φ 15.88		
Liquid pipe	mm	φ 6.35		φ 9.52		
Drain pipe	mm	DN25				

Multi-split Air-conditioning (Heat Pump) Unit

Wall-mounted Type

Wall-mounted type								
Indoor unit model	DFV-22G	DFV-28G	DFV-36G	DFV-45G	DFV-51G	DFV-70G		
Indoor unit power	AC 220V/50HZ/1 φ							
Rated refrigerating capacity	kw	2.2	2.8	3.6	4.5	5.1	7.0	
Rated heating capacity	kw	2.5	3.2	4.0	5.0	5.6	7.7	
Auxiliary electric heating	kw	/						
Rated power	kw	0.04			0.06			
Noise value	dB(A)	24~33			33~40		35~44	
Standard air volume	m ³ /h	390	430	560	800		1050	
Unit dimension	mm	800 × 281 × 190			900 × 296 × 216		1080 × 304 × 221	
Weight	kg	10			12		16	
Refrigerant connecting pipe	Horn-shaped flared connection							
Air pipe	mm	φ 9.52		φ 12.7		φ 15.88		
Liquid pipe	mm	φ 6.35					φ 9.52	
Drain pipe	mm	DN20						

Multi-split Air-conditioning (Heat Pump) Unit

Outdoor Unitary and Parameter Table

Independent outdoor unit									
Type	DFV-252WS	DFV-280WS	DFV-335WS	DFV-400WS	DFV-450WS	DFV-500WS			
Horse power	8	10	12	14	16	18			
Power supply									
Rated refrigerating capacity	kw	25.2	28.0	33.5	40.0	45.0	50.0		
Rated heating capacity	kw	27.4	31.5	37.5	45.0	50.0	56.0		
Power consumption	Refrigeration	kw	6.00	7.00	9.15	11.40	15.00		
	Heating	kw	6.10	7.20	9.14	11.60	13.10	14.90	
IPLV	/	7.55	7.45	7.21	6.92	6.75	6.55		
Noise (sound pressure level A)	dB (A)	45 ~ 58			45 ~ 60				
Fan air volume	m ³ /h	12000			15000				
Housing color	Camel gray								
Unit dimension	Width x depth x height	970x765x1620			1260x765x1620				
Net weight	kg	206		242	298		314		
Refrigerant	Type	R410A							
	Throttle type	Electronic expansion valve throttle							
	Filling volume	kg	10		12	14		16	
Compressor type	Hermetic scroll compressor								
Connecting pipe	Equivalent length of all piping < 90m	Liquid pipe	mm φ 12.7			φ 15.88			
		Air pipe	mm φ 22.2	φ 25.7		φ 28.6		φ 31.8	
	Equivalent length of all piping ≥ 90m	Liquid pipe	mm φ 12.7			φ 15.88			φ 19.05
		Air pipe	mm φ 25.4		φ 28.6		φ 31.8		
Braze connection (low pressure) + threaded connection (high pressure)									
Operating range	Refrigeration	-5°C ~ 50°C							
	Heating	-20°C ~ 30°C							

Multi-split Air-conditioning (Heat Pump) Unit

Multi-split Air-conditioning (Heat Pump) Unit

Modular Type Outdoor Unit

		Module standalone unit parameters								Multi-split unit parameters																									
Product picture		8HP-10HP		12HP-18HP				20HP	22HP-26HP		28HP-36HP				38HP-42HP																				
Horse power		8		10		12		14		16		18		20		22		24		26		28		30		32		34		36		38		40	
Type		DFV-252WSM		DFV-280WSM		DFV-335WSM		DFV-400WSM		DFV-450WSM		DFV-500WSM		DFV-560WSM		DFV-615WSM		DFV-680WSM		DFV-730WSM		DFV-785WSM		DFV-835WSM		DFV-900WSM		DFV-950WSM		DFV-1000WSM		DFV-1065WSM		DFV-1115WSM	
Combination		DFV-252WSM		DFV-280WSM		DFV-335WSM		DFV-400WSM		DFV-450WSM		DFV-500WSM		10HP+10HP		10HP+12HP		10HP+14HP		10HP+16HP		12HP+16HP		12HP+18HP		16HP+16HP		16HP+18HP		18HP+18HP		10HP+12HP+16HP		10HP+12HP+18HP	
Power supply		Three-phase, 50 Hz, 380 v																																	
Rated refrigerating capacity		25.2		28.0		33.5		40.0		45.0		50.0		56.0		61.5		68.0		73.0		78.5		83.5		90.0		95.0		100.0		106.5		111.5	
Rated heating capacity		27.4		31.5		37.5		45.0		50.0		56.0		63.0		69.0		76.5		81.5		87.5		93.5		100.0		106.0		112.0		119.0		125.0	
Power consumption	Refrigeration	6.00		7.00		9.15		11.40		13.50		15.00		14.00		16.15		18.40		20.50		22.65		24.15		27.00		28.50		30.00		29.65		31.15	
	Heating	6.10		7.20		9.14		11.60		13.10		14.90		14.40		16.34		18.80		20.20		22.24		24.04		26.20		28.00		29.80		29.44		31.24	
IPLV		/		7.55		7.45		7.21		6.92		6.75		6.55		/		/		/		/		/		/		/		/		/		/	
Noise (sound pressure level A)		43-58								43-60								43-63																	
Fan air volume		12000				15000								12000×2				12000+15000				15000×2													
Housing color		Camel gray																																	
Unit dimension	W x D x H	970 x 765 x 1620				1260 x 765 x 1620								(970 x 765 x 1620) × 2				10HP+12HP				(970 x 765 x 1620) + (1260 x 765 x 1620)				(1260 x 765 x 1620) × 2				(970 x 765 x 1620) + (1260 x 765 x 1620) × 2					
	Net weight	206		206		242		298		298		314		412		448		504		504		540		556		596		612		628		746		762	
Refrigerant	Type	R410A																																	
	Throttle type	Electronic expansion valve throttle																																	
Compressor type	Charge Qty	10		10		12		14		14		16		20		22		24		24		26		28		30		32		36		38			
	Compressor type	Hermetic scroll compressor																																	
Connecting pipe	Equivalent length of all piping < 90m	Liquid pipe	φ 12.7								φ 15.88								φ 15.88								φ 19.05								
		Air pipe	φ 22.2		φ 25.4		φ 28.6		φ 31.8		φ 31.8		φ 31.8		φ 31.8		φ 31.8		φ 31.8		φ 34.9		φ 34.9		φ 34.9		φ 34.9		φ 34.9		φ 34.9		φ 41.3		
	Equivalent length of all piping ≥ 90m	Liquid pipe	φ 12.7								φ 15.88								φ 19.05								φ 22.2								
		Air pipe	φ 25.4		φ 28.6		φ 31.8		φ 31.8		φ 31.8		φ 31.8		φ 31.8		φ 31.8		φ 31.8		φ 34.9		φ 34.9		φ 34.9		φ 34.9		φ 34.9		φ 34.9		φ 41.3		
Connection type		Braze connection (low pressure) + threaded connection (high pressure)																																	
Oil balance tube		φ 6.35																																	
Max. number of indoor unit can be connected		13		16		16		20		20		20		24		24		28		28		32		32		36		36		36		42			
Operating range	Refrigeration	-5°C~50°C																																	
	Heating	-20°C~30°C																																	

		Multi-split unit parameters								Multi-split unit																								
Product picture		44HP-54HP (add picture)								56-58HP (add picture)								60HP-72HP (add picture)																
Horse power		42		44		46		48		50		52		54		56		58		60		62		64		66		68		70		72		
Type		DFV-1180WSM		DFV-1235WSM		DFV-1285WSM		DFV-1350WSM		DFV-1400WSM		DFV-1450WSM		DFV-1500WSM		DFV-1580WSM		DFV-1630WSM		DFV-1685WSM		DFV-1735WSM		DFV-1800WSM		DFV-1850WSM		DFV-1900WSM		DFV-1950WSM		DFV-2000WSM		
Combination		10HP+16HP×2		12HP+16HP×2		12HP+16HP+18HP		16HP×3		16HP×2+18HP		16HP+18HP×2		18HP×3		16HP×3+8HP		16HP×3+10HP		16HP×3+12HP		12HP+16HP×2+18HP		16HP×4		16HP×3+18HP		16HP×2+18HP×2		16HP+18HP×3		18HP×4		
Power supply		Three-phase, 50 Hz, 380 v																																
Rated refrigerating capacity		118		123.5		128.5		135.0		140.0		145.0		150.0		158.0		163.0		168.5		173.5		180.0		185.0		190.0		195.0		200.0		
Rated heating capacity		131.5		137.5		143.5		150.0		156.0		162.0		168.0		176.5		181.5		187.5		193.5		200.0		206.0		212.0		218.0		224.0		
Power consumption	Refrigeration	34.00		36.15		37.65		40.50		42.00		43.50		45.00		45.40		47.50		49.65		51.15		54.00		55.50		57.00		58.50		60.00		
	Heating	33.40		35.34		37.14		39.30		41.10		42.90		44.70		45.00		46.50		48.44		50.24		52.40		54.20		56.00		57.80		59.60		
IPLV		/		/		/		/		/		/		/		/		/		/		/		/		/		/		/		/		
Noise (sound pressure level A)		43-63								44-63								44-63																
Fan air volume		12000+15000×2				15000×3								12000+15000×3				15000×4																
Housing color		Camel gray																																
Unit dimension	W x D x H	(970 x 765 x 1620) + (1260 x 765 x 1620) × 2				(1260 x 765 x 1620) × 3								(1260 x 765 x 1620) × 3 + (970 x 765 x 1620)				(1260 x 765 x 1620) × 4																
	Net weight	802		838		854		894		910		926		942		1100		1100		1136		1152		1192		1208		1224		1240		1256		
Refrigerant	Type	R410A																																
	Throttle type	Electronic expansion valve throttle																																
Compressor type	Charge Qty	38		40		42		42		44		46		48		52		52		54		56		58		60		62		64				
	Compressor type	Hermetic scroll compressor																																
Connecting pipe	Equivalent length of all piping < 90m	Liquid pipe	φ 19.05								φ 22.2								φ 22.2								φ 25.4							
		Air pipe	φ 41.3		φ 41.3		φ 41.3		φ 41.3		φ 41.3		φ 41.3		φ 41.3		φ 41.3		φ 41.3		φ 41.3		φ 41.3		φ 41.3		φ 41.3		φ 41.3		φ 41.3			
	Equivalent length of all piping ≥ 90m	Liquid pipe	φ 22.2								φ 25.4								φ 25.4								φ 25.4							
		Air pipe	φ 41.3		φ 41.3		φ 41.3		φ 41.3		φ 41.3		φ 41.3		φ 41.3		φ 41.3		φ 41.3		φ 41.3		φ 41.3		φ 41.3		φ 41.3		φ 41.3		φ 41.3		φ 41.3	
Connection type		Braze connection (low pressure) + threaded connection (high pressure)																																
Oil balance tube		φ 6.35																																
Max. number of indoor unit can be connected		42		42		48		48		54		54		54		58		58		58		64		64		64		64		64		64		
Operating range	Refrigeration	-5°C~50°C																																
	Heating	-20°C~30°C																																

Multi-split Air-conditioning (Heat Pump) Unit

Independent outdoor unit										
Type		DFV-530WS	DFV-560WS	DFV-600WS	DFV-670WS	DFV-730WS	DFV-800WS	DFV-850WS	DFV-900WS	
Horse power		18	20	22	24	26	28	30	32	
Power supply		Three-phase, 50 Hz, 380 v								
Rated refrigerating capacity		KW	53.0	56.0	60.0	67.0	73.0	80.0	85.0	90.0
Rated heating capacity		KW	60.0	63.0	67.0	75.0	81.5	88.0	95.0	100.0
Power consumption	Refrigeration	KW	16.70	17.60	18.30	20.80	22.30	26.60	27.30	28.20
	Heating	KW	16.00	17.00	17.80	19.80	20.60	25.40	26.00	26.80
IPLV		/	6.80	6.75	6.55	6.40	6.90	6.18	6.12	6.05
Noise (sound pressure level A)		dB (A)	45-63				45-65			
Fan air volume		m ³ /h	24000				30000			
Housing color			Camel gray							
Unit dimension		W x D x H	1970 x 765 x 1620				2541 x 765 x 1620			
Net weight		kg	390			530		541		
Refrigerant		Type	R410A							
		Throttle type	Electronic expansion valve throttle							
		Charge Qty	Kg		17		23		31	
Compressor type			Hermetic scroll compressor							
Connecting pipe	Equivalent length of all piping < 90m	Liquid pipe	mm	φ 15.88			φ 19.05			
		Air pipe	mm	φ 31.8			φ 34.9			
	Equivalent length of all piping ≥ 90m	Liquid pipe	mm	φ 19.05			φ 22.2			
		Air pipe	mm	φ 31.8			φ 38.1			
Connection type			Brazed connection (low pressure) + threaded connection (high pressure)							
Operating range		Refrigeration	-5°C-50°C							
		Heating	-20°C-30°C							

Cabinet Type Air-handling Unit (LEG)

Product Overview

DunAn patent fastening type plate and frame integrated air-handling unit is a kind of new aluminum alloy frame developed by our company. The unit is mainly consisted of filter, oval tube exchanger tube, fan, and motor, etc., meeting the requirements of various residual pressures, various cooling capacity, and various air outlet forms. Its housing is directly assembled by side panels and the panel frame adopt patent aluminum alloy and insulation composite structure, so as to install the panel in place accurately, which guarantee the tightness of case and anti-cold bridge as well as the case strength.

This series of unit operate stably, with low noise and excellent overall performance. It can be widely used in hotels, shopping malls, office buildings, stadiums, subways and other occasions requiring air-handling.



Key Technology - Oval Tube Heat Exchanger

Features of oval tube heat exchanger:

- Reduce the wind resistance by 50%, with low fan energy consumption
- Increase the heat transfer efficiency by 10%-15%, guaranteeing excellent unit performance
- Anti-corrosive hydrophilic aluminum fin, ensures longer service life

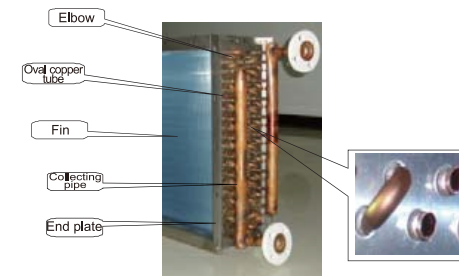

Lower Wind Resistance:

Under same tube spacing, increasing the net flow area between tubes can decrease the net face velocity and reduce the turbulence on the leeward side of oval tube, so as to reduce the wind resistance. The following figures on the left are the comparison of wind-side resistance test results between oval tube heat exchanger and circular tube heat exchanger under different wind velocities. It can be seen from the figure that the wind-side resistance of oval tube heat exchanger is about 50% lower than that of circular tube heat exchanger.

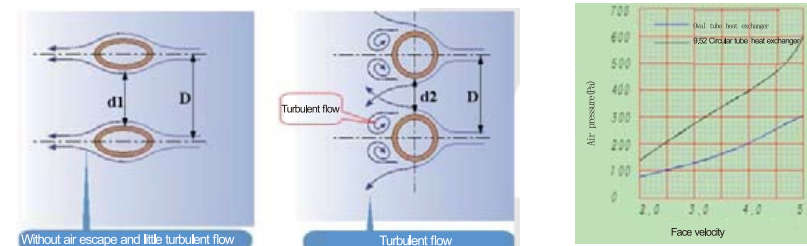

Airflow disturbance diagram

Cabinet Type Air-handling Unit (LEG)

Higher Heat Transfer Coefficient:

Oval tube avoids the escape of airflow in circular tube, increasing the effective contact surface area by 40%, so as to improve the efficiency of heat exchange. The following figure on the right is the comparison of heat transfer coefficient test results between oval tube heat exchanger and circular tube heat exchanger under different wind velocities. It can be seen from the figure that the heat transfer coefficient of oval tube heat exchanger is about 10%-15% higher than that of circular tube heat exchanger.

More energy saving:

Analysis and comparison of energy saving for oval tube heat exchanger and circular tube heat exchanger

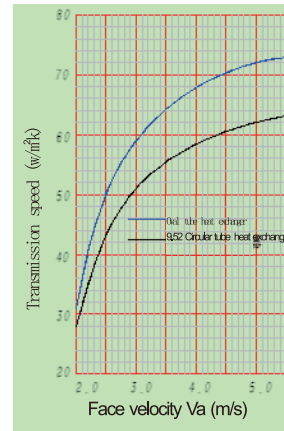

$$\text{Air transmission power(kW)} = \frac{\text{Air volume (m}^3\text{/h)} \times \text{air resistance (Pa)}}{1000 \times 3600 \times \text{Motor efficiency } (\eta_m) \times \text{Fan efficiency } (\eta_f)}$$

Take a single 100000m³/h cabinet as an example to compare the air delivery cost between oval tube heat exchanger and circular tube heat exchanger. Calculated by annual using hours of 3000, the oval tube heat exchanger can save annual cost of (34156-16187) = 17970 (RMB);

Relatively saving cost: (17970/34156)=53%.

Relatively Annual Saving Cost: 53%

Unit Model Denotation Method

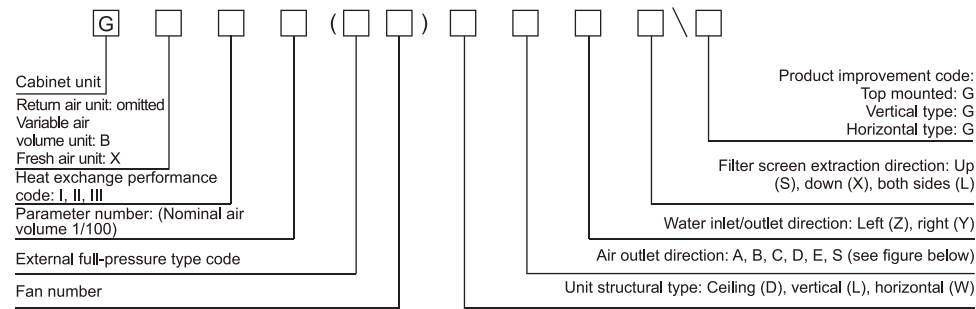

(Unit left/right direction identification is decided by facing the return air inlet)

Cabinet Type Air-handling Unit (LEG)

Type I (Return Air) Performance Parameter Table

Unit model	Air volume m ³ /h	Refrigerating capacity kW	Heating capacity kW	Water flow m ³ /h	Water resistance kPa	External residual pressure				Motor power kW				Rated current A				Noise dB (A)			
						I	II	III	IV	I	II	III	IV	I	II	III	IV	I	II	III	IV
G I 15(1)	1500	8.4	14.2	1.5	10.0	120	180	280	\	0.2	0.25	0.32	\	0.8	0.9	1.3	\	51	52	56	\
G I 20(1)	2000	11.6	18.3	2.0	12.9	120	280	350	\	0.32	0.45	0.55	\	1.3	1.9	2.0	\	56	57	58	\
G I 25(1)	2500	14.5	24.2	2.5	15.9	120	260	340	\	0.32	0.45	0.55	\	1.3	1.9	2.0	\	58	58	58	\
G I 30(1)	3000	16.5	29.8	2.9	18.5	180	240	340	\	0.45	0.55	0.55	\	1.9	2.0	2.0	\	58	58	58	\
G I 40(1)	4000	23.4	43.8	4.1	26.8	220	270	370	\	0.75	0.75	1	\	2.3	2.3	3	\	58	60	60	\
G I 50(1)	5000	28.4	55.9	4.9	6.5	200	300	420	\	0.75	1	1.3	\	2.3	3	3.4	\	60	62	62	\
G I 60(1)	6000	34.8	67.2	6.0	8.0	180	250	330	410	1.1	1.5	1.5	2.2	2.74	3.67	3.67	4.9	56	57	58	60
G I 70(1)	7000	40.8	77.5	7.1	11.0	180	250	330	410	1.1	1.1	1.5	2.2	2.93	2.93	3.67	4.9	59	60	61	62
G I 80(1)	8000	47.5	88.6	8.2	14.3	180	250	330	410	1.5	1.5	2.2	3	3.86	3.86	4.9	6.5	59	59	60	61
G I 90(1)	9000	54.7	99.7	9.5	18.7	180	280	380	480	1.5	2.2	2.2	3	3.86	4.9	4.9	6.5	62	62	62	63
G I 100(1)	10000	61.5	112.1	10.6	24.3	180	280	380	480	2.2	2.2	3	3	5.52	5.52	6.5	6.5	63	63	64	65
G I 120(2)	12000	72.0	140.8	12.5	31.1	180	280	380	480	2.2	3	4	4	4.9	6.5	8.56	8.56	59	61	63	65
G I 150(2)	15000	92.1	165.8	15.9	32.4	180	280	380	480	2.2	3	4	4	5.52	7.39	8.56	8.56	64	64	65	67
G I 180(2)	18000	110.2	215.1	19.0	38.6	200	300	400	500	4	5.5	5.5	7.5	8.56	11.6	11.6	15.3	65	65	66	67
G I 200(2)	20000	126.7	226.1	21.9	39.8	200	300	400	500	5.5	5.5	5.5	7.5	11.6	11.6	15.3	66	67	68	69	
G I 240(2)	24000	149.0	272.0	25.7	24.2	200	300	400	500	5.5	5.5	7.5	11	13.0	11.6	15.3	21.9	66	66	67	68
G I 270(2)	27000	168.0	306.0	29.0	23.9	300	400	500	600	7.5	11	11	11	15.3	21.9	21.9	21.9	69	69	70	71
G I 300(2)	30000	189.1	340.4	32.6	23.7	300	400	500	600	7.5	11	11	11	16.8	21.9	21.9	21.9	68	69	69	70
G I 350(2)	35000	221.2	395.0	38.2	26.3	300	400	500	600	7.5	11	11	15	16.8	21.9	21.9	29.3	68	69	70	71
G I 400(2)	40000	250.8	451.4	43.2	24.0	300	400	500	600	11	11	15	15	23.9	21.9	29.3	29.3	71	72	72	73
G I 450(2)	45000	282.2	507.9	48.7	24.0	300	400	500	600	15	15	15	18.5	31.4	31.4	29.3	35.8	74	74	75	75

Refrigerating working condition of standard return air: Air inlet dry bulb temperature: 27 °C, air inlet wet bulb temperature: 19.5 °C, water inlet temperature: 7 °C, and water outlet temperature: 12 °C;

Heating working condition of standard return air: Air inlet dry bulb temperature: 15 °C, water inlet temperature: 60 °C

Type II (Return Air) Performance Parameter Table

Unit model	Air volume m ³ /h	Refrigerating capacity kW	Heating capacity kW	Water flow m ³ /h	Water resistance kPa	External residual pressure				Motor power kW				Rated current A				Noise dB (A)			
						I	II	III	IV	I	II	III	IV	I	II	III	IV	I	II	III	IV
G II 15(1)	1500	11.2	18.3	2.0	26.0	90	150	250	\	0.2	0.25	0.32	\	0.8	0.9	1.3	\	51	52	56	\
G II 20(1)	2000	15.2	23.6	2.7	33.2	90	250	320	\	0.32	0.45	0.55	\	1.3	1.9	2.0	\	56	57	58	\
G II 25(1)	2500	18.5	28.5	3.2	29.5	90	230	310	\	0.32	0.45	0.55	\	1.3	1.9	2.0	\	58	58	58	\
G II 30(1)	3000	22.7	36.6	4.0	8.3	150	210	310	\	0.45	0.55	0.55	\	1.9	2.0	2.0	\	58	58	58	\
G II 40(1)	4000	31.5	51.4	5.5	11.0	190	240	340	\	0.75	0.75	1	\	2.3	2.3	3	\	58	60	60	\
G II 50(1)	5000	36.8	64.1	6.4	14.5	170	270	390	\	0.75	1	1.3	\	2.3	3	3.4	\	60	62	62	\
G II 60(1)	6000	44.9	74.7	7.8	17.1	180	250	330	410	1.1	1.5	1.5	2.2	2.74	3.67	3.67	4.9	56	57	58	60
G II 70(1)	7000	51.6	86.7	8.9	23.8	180	250	330	410	1.1	1.5	1.5	2.2	2.93	3.86	3.67	4.9	59	60	61	62
G II 80(1)	8000	62.8	100.5	10.9	32.0	180	250	330	410	1.5	1.5	2.2	3	3.86	3.86	4.9	6.5	59	59	60	61
G II 90(1)	9000	71.2	113.0	12.3	15.0	180	280	380	480	1.5	2.2	2.2	3	3.86	4.9	4.9	6.5	62	62	62	63
G II 100(1)	10000	79.2	122.0	13.7	18.2	180	280	380	480	2.2	2.2	3	3	5.52	4.9	6.5	6.5	63	63	64	65
G II 120(2)	12000	97.1	150.8	16.8	30.6	180	280	380	480	2.2	3	4	4	4.9	6.5	8.56	8.56	59	61	63	65
G II 150(2)	15000	113.8	175.3	19.7	32.5	180	280	380	480	3	3	4	5.5	7.39	6.5	8.56	11.6	64	64	65	67
G II 180(2)	18000	136.6	210.3	23.6	25.0	200	300	400	500	4	5.5	5.5	7.5	8.56	11.6	11.6	15.3	65	65	66	67
G II 200(2)	20000	159.2	233.6	27.5	27.2	200	300	400	500	5.5	5.5	7.5	7.5	11.6	11.6	15.3	15.3	66	67	68	69
G II 240(2)	24000	182.0	280.3	31.4	38.7	200	300	400	500	5.5	7.5	7.5	11	13.0	15.3	21.9	66	66	67	68	
G II 270(2)	27000	204.7	315.2	35.3	38.2	300	400	500	600	7.5	11	11	11	15.3	21.9	21.9	21.9	69	69	70	71
G II 300(2)	30000	228.6	352.1	39.4	38.1	300	400	500	600	7.5	11	11	11	16.8	21.9	21.9	21.9	68	69	69	70
G II 350(2)	35000	275.2	408.6	47.5	39.2	300	400	500	600	11	11	11	15	23.9	21.9	21.9	29.3	68	69	70	71
G II 400(2)	40000	303.2	467.0	52.3	39.5	300	400	500	600	11	15	15	15	23.9	21.9	29.3	29.3	71	72	72	73
G II 450(2)	45000	341.2	525.4	58.8	46.8	300	400	500	600	15	15	15	18.5	31.4	31.4	29.3	35.8	74	74	75	75

Refrigerating working condition of standard return air: Air inlet dry bulb temperature: 27 °C, air inlet wet bulb temperature: 19.5 °C, water inlet temperature: 7 °C, and water outlet temperature: 12 °C;

Heating working condition of standard return air: Air inlet dry bulb temperature: 15 °C, water inlet temperature: 60 °C

Cabinet Type Air-handling Unit (LEG)

Type III (Return Air) Performance Parameter Table

Unit model	Air volume m³/h	Refrigerating capacity kW	Heating capacity kW	Water flow m³/h	Water resistance kPa	External residual pressure				Motor power kW				Rated current A				Noise dB (A)			
						I	II	III	IV	I	II	III	IV	I	II	III	IV	I	II	III	IV
G III 15(1)	1500	12.6	20.9	2.2	9.6	80	140	240	\	0.2	0.25	0.32	\	0.8	0.9	1.3	\	51	52	56	\
G III 20(1)	2000	16.5	27.0	2.9	9.8	80	240	310	\	0.32	0.45	0.55	\	1.3	1.9	2.0	\	56	57	58	\
G III 25(1)	2500	21.0	32.6	3.7	12.7	80	220	300	\	0.32	0.45	0.55	\	1.3	1.9	2.0	\	58	58	58	\
G III 30(1)	3000	25.1	41.9	4.4	14.3	140	200	300	\	0.45	0.55	0.55	\	1.9	2.0	2.0	\	58	58	58	\
G III 40(1)	4000	33.8	58.8	5.9	17.5	180	230	330	\	0.75	0.75	1	\	2.3	2.3	3	\	58	60	60	\
G III 50(1)	5000	42.5	73.4	7.4	23.0	160	260	380	\	0.75	1	1.3	\	2.3	3	3.4	\	60	62	62	\
G III 60(1)	6000	51.4	85.5	8.9	27.2	220	290	370	450	1.5	1.5	2.2	2.2	3.67	3.67	4.9	4.9	56	57	58	60
G III 70(1)	7000	56.6	99.2	9.8	38.1	220	290	370	450	1.5	1.5	2.2	2.2	3.86	3.67	4.9	4.9	59	60	61	62
G III 80(1)	8000	68.5	115.1	11.8	8.8	220	290	370	450	1.5	2.2	2.2	2.2	3.67	4.9	4.9	4.9	59	59	60	61
G III 90(1)	9000	78.2	129.4	13.5	11.5	220	320	420	520	2.2	2.2	3	3	4.9	4.9	6.5	6.5	62	62	62	63
G III 100(1)	10000	87.6	139.6	15.1	13.9	220	320	420	520	2.2	3	3	4	4.9	6.5	6.5	8.56	63	63	64	65
G III 120(2)	12000	106.5	172.6	18.4	23.4	220	320	420	520	3	4	4	5.5	6.5	8.56	8.56	11.6	59	61	63	65
G III 150(2)	15000	130.3	200.6	22.5	24.8	220	320	420	520	3	4	5.5	5.5	6.5	8.56	11.6	11.6	64	64	65	67
G III 180(2)	18000	156.3	240.7	27.0	20.7	200	300	400	500	4	5.5	5.5	7.5	8.56	11.6	11.6	15.3	65	65	66	67
G III 200(2)	20000	173.6	267.4	30.0	22.5	200	300	400	500	5.5	5.5	7.5	7.5	11.6	11.6	15.3	15.3	66	67	68	69
G III 240(2)	24000	198.2	320.8	34.2	33.5	200	300	400	500	5.5	7.5	7.5	11	13.0	16.8	15.3	21.9	66	66	67	68
G III 270(2)	27000	225.3	360.9	38.9	33.0	300	400	500	600	7.5	11	11	11	16.8	21.9	21.9	21.9	69	69	70	71
G III 300(2)	30000	261.7	403.0	45.1	35.5	300	400	500	600	7.5	11	11	11	16.8	21.9	21.9	21.9	68	69	69	70
G III 350(2)	35000	303.7	467.8	52.4	39.4	300	400	500	600	11	11	11	15	23.9	23.9	21.9	29.3	68	69	70	71
G III 400(2)	40000	347.1	534.6	59.8	36.6	300	400	500	600	11	11	15	15	23.9	23.9	29.3	29.3	71	72	72	73
G III 450(2)	45000	390.6	601.5	67.3	36.6	300	400	500	600	15	15	15	18.5	31.4	31.4	29.3	35.8	74	74	75	75

Refrigerating working condition of standard return air: Air inlet dry bulb temperature: 27 °C, air inlet wet bulb temperature: 19.5 °C, water inlet temperature: 7 °C, and water outlet temperature: 12 °C;
 Heating working condition of standard return air: Air inlet dry bulb temperature: 15 °C, water inlet temperature: 60 °C

Type I (Fresh Air) Performance Parameter Table

Unit model	Air volume m³/h	Refrigerating capacity kW	Heating capacity kW	Water flow m³/h	Water resistance kPa	External residual pressure				Motor power kW				Rated current A				Noise dB (A)			
						I	II	III	IV	I	II	III	IV	I	II	III	IV	I	II	III	IV
GX I 15(1)	1500	19.6	21.1	3.4	8.0	120	180	280	\	0.2	0.25	0.32	\	0.8	0.9	1.3	\	51	52	56	\
GX I 20(1)	2000	27.1	28.4	4.7	10.6	120	280	350	\	0.32	0.45	0.55	\	1.3	1.9	2.0	\	56	57	58	\
GX I 25(1)	2500	31.7	34.9	5.5	16.1	120	260	340	\	0.32	0.45	0.55	\	1.3	1.9	2.0	\	58	58	58	\
GX I 30(1)	3000	40.1	42.1	7.0	24.2	180	240	340	\	0.45	0.55	0.55	\	1.9	2.0	2.0	\	58	58	58	\
GX I 40(1)	4000	53.4	58.7	9.2	30.0	220	270	370	\	0.75	0.75	1	\	2.3	2.3	3	\	58	60	60	\
GX I 50(1)	5000	64.8	74.1	11.2	8.0	200	300	420	\	0.75	1	1.3	\	2.3	3	3.4	\	60	62	62	\
GX I 60(1)	6000	75.0	82.5	13.0	7.7	180	250	330	410	1.1	1.5	1.5	2.2	2.74	3.67	3.67	4.9	56	57	58	60
GX I 70(1)	7000	88.1	96.9	15.2	7.8	180	250	330	410	1.1	1.1	1.5	2.2	2.93	3.67	3.67	4.9	59	60	61	62
GX I 80(1)	8000	101.3	111.4	17.5	10.3	180	250	330	410	1.5	1.5	2.2	3	3.86	3.86	4.9	6.5	59	59	60	61
GX I 90(1)	9000	113.2	124.5	19.5	13.5	180	280	380	480	1.5	2.2	2.2	3	3.86	4.9	4.9	6.5	62	62	62	63
GX I 100(1)	10000	134.0	139.0	23.1	17.0	180	280	380	480	2.2	2.2	3	3	5.52	5.52	6.5	6.5	63	63	64	65
GX I 120(2)	12000	166.2	182.8	28.7	25.7	180	280	380	480	2.2	3	4	4	4.9	6.5	8.56	8.56	59	61	63	65
GX I 150(2)	15000	189.5	208.5	32.7	26.0	180	280	380	480	2.2	3	4	4	5.52	7.39	8.56	8.56	64	64	65	67
GX I 180(2)	18000	238.0	250.2	41.0	25.6	200	300	400	500	4	5.5	5.5	7.5	8.56	11.6	11.6	15.3	65	65	66	67
GX I 200(2)	20000	279.0	278.0	48.1	29.4	200	300	400	500	5.5	5.5	5.5	7.5	11.6	11.6	11.6	15.3	66	67	68	69
GX I 240(2)	24000	325.0	333.6	56.0	35.7	200	300	400	500	5.5	5.5	7.5	11	13.0	11.6	15.3	21.9	66	66	67	68
GX I 270(2)	27000	368.0	375.3	63.4	36.1	300	400	500	600	7.5	11	11	11	15.3	21.9	21.9	21.9	69	69	70	71
GX I 300(2)	30000	402.0	417.0	69.3	33.3	300	400	500	600	7.5	11	11	11	16.8	21.9	21.9	21.9	68	69	69	70
GX I 350(2)	35000	472.0	486.5	81.4	37.3	300	400	500	600	7.5	11	11	15	16.8	21.9	21.9	29.3	68	69	70	71
GX I 400(2)	40000	505.4	556.0	87.1	38.3	300	400	500	600	11	11	15	15	23.9	21.9	29.3	29.3	71	72	72	73
GX I 450(2)	45000	568.6	625.5	98.0	37.0	300	400	500	600	15	15	15	18.5	31.4	31.4	29.3	35.8	74	74	75	75

Refrigerating working condition of standard fresh air: Air inlet dry bulb temperature: 35 °C, air inlet wet bulb temperature: 28 °C, water inlet temperature: 7 °C, and water outlet temperature: 12 °C;
 Heating working condition of standard fresh air: Air inlet dry bulb temperature: 7 °C, water inlet temperature: 60 °C

Cabinet Type Air-handling Unit (LEG)

Type II (Fresh Air) Performance Parameter Table

Unit model	Air volume m³/h	Refrigerating capacity kW	Heating capacity kW	Water flow m³/h	Water resistance kPa	External residual pressure				Motor power kW				Rated current A				Noise dB (A)			
						I	II	III	IV	I	II	III	IV	I	II	III	IV	I	II	III	IV
GX II 15(1)	1500	24.9	28.3	4.3	21.6	90	150	250	\	0.2	0.25	0.32	\	0.8	0.9	1.3	\	51	52	56	\
GX II 20(1)	2000	33.2	37.8	5.8	23.5	90	250	320	\	0.32	0.45	0.55	\	1.3	1.9	2.0	\	56	57	58	\
GX II 25(1)	2500	41.6	45.8	7.2	30.5	90	230	310	\	0.32	0.45	0.55	\	1.3	1.9	2.0	\	58	58	58	\
GX II 30(1)	3000	50.7	55.9	8.8	31.3	150	210	310	\	0.45	0.55	0.55	\	1.9	2.0	2.0	\	58	58	58	\
GX II 40(1)	4000	68.5	78.7	11.8	15.4	190	240	340	\	0.75	0.75	1	\	2.3	2.3	3	\	58	60	60	\
GX II 50(1)	5000	83.5	98.5	14.4	20.3	170	270	390	\	0.75	1	1.3	\	2.3	3	3.4	\	60	62	62	\
GX II 60(1)	6000	101.9	112.1	17.6	25.3	180	250	330	410	1.1	1.5	1.5	2.2	2.74	3.67	3.67	4.9	56	57	58	60
GX II 70(1)	7000	118.9	130.8	20.5	35.1	180	250	330	410	1.1	1.5	1.5	2.2	2.93	3.86	3.67	4.9	59	60	61	62
GX II 80(1)	8000	132.0	151.8	22.8	37.7	180	250	330	410	1.5	1.5	2.2	3	3.86	3.86	4.9	6.5	59	59	60	61
GX II 90(1)	9000	152.9	168.2	26.4	11.6	180	280	380	480	1.5	2.2	2.2	3	3.86	4.9	4.9	6.5	62	62	62	63
GX II 100(1)	10000	172.2	189.4	29.7	16.9	180	280	380	480	2.2	2.2	3	3	5.52	4.9	6.5	6.5	63	63	64	65
GX II 120(2)	12000	205.0	233.1	35.4	25.6	180	280	380	480	2.2	3	4	4	4.9	6.5	8.56	8.56	59	61	63	65
GX II 150(2)	15000	258.7	284.6	44.6	29.1	180	280	380	480	3	3	4	5.5	7.39	6.5	8.56	11.6	64	64	65	67
GX II 180(2)	18000	310.5	341.6	53.5	25.5	200	300	400	500	4	5.5	5.5	7.5	8.56	11.6	11.6	15.3	65	65	66	67
GX II 200(2)	20000	345.0	379.5	59.5	27.5	200	300	400	500	5.5	5.5	5.5	7.5	7.5	11.6	11.6	15.3	66	67	68	69
GX II 240(2)	24000	414.0	455.4	71.4	39.9	200	300	400	500	5.5	7.5	7.5	11	13.0	15.3	15.3	21.9	66	66	67	68
GX II 270(2)	27000	465.7	512.3	80.3	39.4	300	400	500	600	7.5	11	11	11	15.3	21.9	21.9	21.9	69	69</		

Cabinet Type Air-handling Unit (G Series)

Higher Heat Transfer Coefficient:

The G series air-handling unit adopts a case structure of patented profiles, which features by three layers of seals, PVC insulation cold bridge, and high strength, etc., so as to effectively guarantee low air leakage rate, no cold bridge, high strength and other technical features of DunAn air-conditioning unit. To better adhere to the original intention of DunAn in leading a healthy and comfort environment, DunAn launches five types of air-handling units: horizontal unit 1, horizontal unit 2, horizontal unit 3, horizontal unit 4, and horizontal unit 5. The air volume of these units varies from 1500 m³/h to 45000 m³/h. There are many types of residual pressure, multiple cooling capacities, and multiple air outlets for selection, and the wet-membrane humidifier can be configured according to the user's requirements.

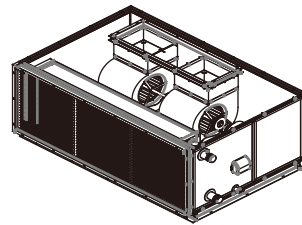

Patented Core Technology - Oval Tube Heat Exchanger

Features of oval tube heat exchanger:

- Reduce the wind resistance by 50%, with low fan energy consumption
- Increase the heat transfer efficiency by 10%-15%, guaranteeing ent unit performance
- Anti-corrosive hydrophilic aluminum fin, enjoying longer service life

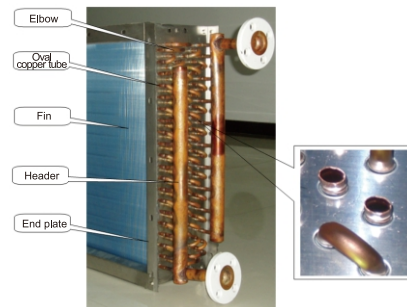

Lower wind resistance:

Under same tube spacing, increasing the net flow area between tubes can decrease the net face velocity and reduce the turbulence on the leeward side of oval tube, so as to reduce the wind resistance. The following figures on the left are the comparison of wind-side resistance test results between oval tube heat exchanger and circular tube heat exchanger under different wind velocities. It can be seen from the figure that the wind-side resistance of oval tube heat exchanger is about 50% lower than that of circular tube heat exchanger.

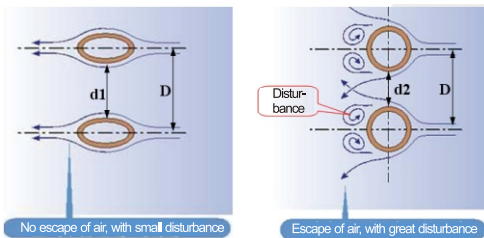

Airflow disturbance diagram

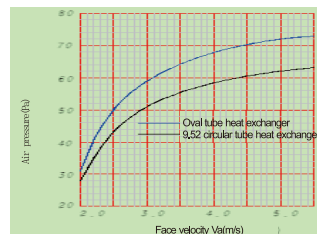
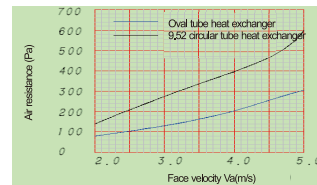

Cabinet Type Air-handling Unit (G Series)

Higher Heat Transfer Coefficient

Oval tube avoids the escape of airflow in circular tube, increasing the effective contact surface area by 40%, so as to improve the efficiency of heat exchange. The following figure on the right is the comparison of heat transfer coefficient test results between oval tube heat exchanger and circular tube heat exchanger under different wind velocities. It can be seen from the figure that the heat transfer coefficient of oval tube heat exchangers about 10%-15% higher than that of circular tube heat exchanger.

More Energy Saving

Analysis and comparison of energy saving for oval tube heat exchanger and circular tube heat exchanger

$$\text{Air delivery power (kW)} = \frac{\text{Air volume (m}^3\text{/h)} \times \text{Air resistance (Pa)}}{1000 \times 3600 \times \text{Motor efficiency } (\eta_m) \times \text{Fan efficiency } (\eta_f)}$$

Take a single 100000m³/h cabinet as an example to compare the air delivery cost between oval tube heat exchanger and circular tube heat exchanger. Calculated by annual using hours of 3000, the oval tube heat exchanger can save annual cost of (34156-16187) = 17970 (RMB); Relatively saving cost is:

(17970/34156)=53%.



Relatively annual saving cost is:

Unit Model Denotation Method

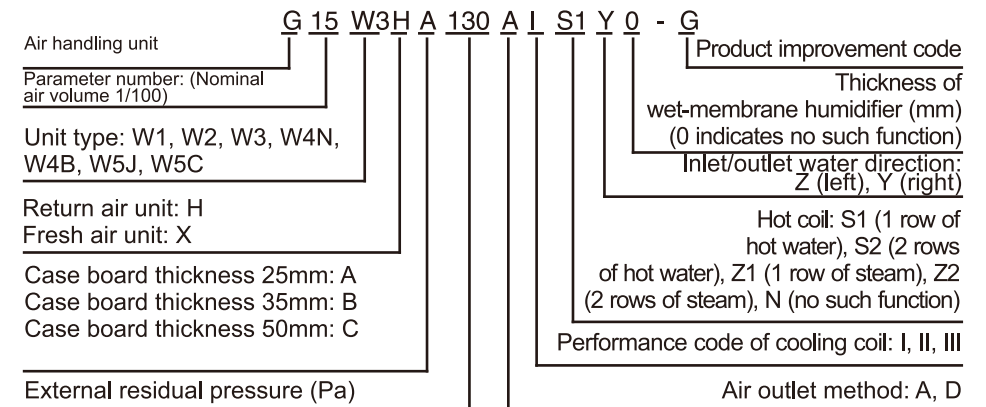

Cabinet Type Air-handling Unit (G Series)

Unit Type

W1-Horizontal unit 1

Mixing + Primary-efficiency filtering + Surface cooling + Fan

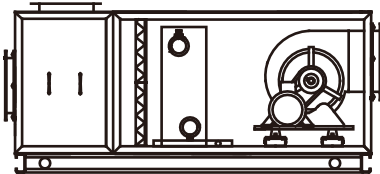

W2-Horizontal unit 2

Mixing + Primary-efficiency filtering + Medium-efficiency filtering + Surface cooling + Fan

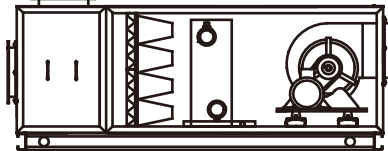

W3-Horizontal unit 3

Mixing + Primary-efficiency filtering + Surface cooling + Hot water coil/steam coil + Fan

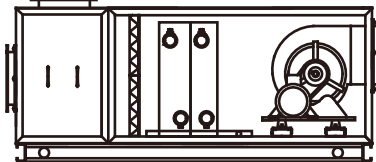

W4-Horizontal unit 4 (W4N - Nylon filter; W4B - Plate-type filter)

External slide (plate-type primary-efficiency/nylon) + Surface cooling + Fan

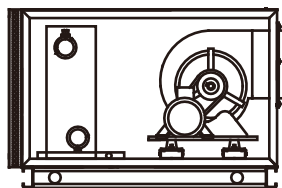

W5-Horizontal unit 5 (W5J - Electrostatic dust collection; W5C - Activated carbon)

External slide (plate-type primary-efficiency) + Electrostatic dust collection/activated carbon + Surface cooling + Fan

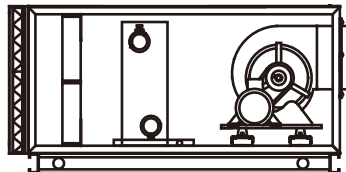

Note: The above unit combination can increase wet film humidification, with the film thickness of 50mm/100mm/200mm optional.

Cabinet Type Air-handling Unit (G Series)

(Return Air) Performance Parameter Table

Unit model G	Air volume m ³ /h	Cooling capacity (kW)			Heating capacity (kW)			Water flow m ³ /h			Water resistance (kPa)			Noise dB(A)		
		I	II	III	I	II	III	I	II	III	I	II	III	I	II	III
15-G	1500	8.4	11.2	12.6	14.2	18.3	20.9	1.5	2.0	2.2	8.2	26.0	9.6	51	52	56
20-G	2000	11.6	15.2	16.5	18.3	23.6	27.0	2.0	2.7	2.9	11.7	33.2	9.8	56	57	58
25-G	2500	14.5	18.5	21.0	24.2	28.5	32.6	2.5	3.2	3.7	17.6	29.5	12.7	58	58	58
30-G	3000	16.5	22.7	25.1	29.8	36.6	41.9	2.9	4.0	4.4	5.0	8.3	14.3	58	58	58
40-G	4000	23.4	31.5	33.8	43.8	51.4	58.8	4.1	5.5	5.9	6.4	11.0	17.5	58	60	60
50-G	5000	28.4	36.8	42.5	55.9	64.1	73.4	4.9	6.4	7.4	9.7	14.5	23.0	60	62	62
60-G	6000	34.8	44.9	51.4	67.2	74.7	85.5	6.0	7.8	8.9	9.5	17.1	27.2	56	57	58
70-G	7000	40.8	51.6	56.6	77.5	86.7	99.2	7.1	8.9	9.8	9.6	23.8	38.1	59	60	61
80-G	8000	47.5	62.8	68.5	88.6	100.5	115.1	8.2	10.9	11.8	12.9	32.0	8.8	59	59	60
90-G	9000	54.7	71.2	78.2	99.7	113.0	129.4	9.5	12.3	13.5	17.0	15.0	11.5	62	62	62
100-G	10000	61.5	79.2	87.6	112.1	122.0	139.6	10.6	13.7	15.1	21.6	18.2	13.9	63	63	64
120-G	12000	72.0	97.1	106.5	140.8	150.8	172.6	12.5	16.8	18.4	11.1	30.6	23.4	59	61	63
150-G	15000	92.1	113.8	130.3	165.8	175.3	200.6	15.9	19.7	22.5	17.0	32.5	24.8	64	64	65
180-G	18000	110.2	136.6	156.3	215.1	210.3	240.7	19.0	23.6	27.0	16.1	25.0	20.7	65	65	66
200-G	20000	126.7	159.2	173.6	226.1	233.6	267.4	21.9	27.5	30.0	18.0	27.2	22.5	66	67	68
240-G	24000	149.0	182.0	198.2	272.0	280.3	320.8	25.7	31.4	34.2	25.3	38.7	33.5	66	66	67
270-G	27000	168.0	204.7	225.3	306.0	315.2	360.9	29.0	35.3	38.9	25.6	38.2	33.0	69	69	70
300-G	30000	189.1	228.6	261.7	340.4	352.1	403.0	32.6	39.4	45.1	24.6	38.1	35.5	68	69	69
350-G	35000	221.2	275.2	303.7	395.0	408.6	467.8	38.2	47.5	52.4	26.7	39.2	39.4	68	69	70
400-G	40000	250.8	303.2	347.1	451.4	467.0	534.6	43.2	52.3	59.8	27.0	39.5	36.6	71	72	72
450-G	45000	282.2	341.2	390.6	507.9	525.4	601.5	48.7	58.8	67.3	26.6	46.8	36.6	74	74	75

※ Refrigerating working condition of standard return air: Inlet air dry bulb temperature: 27 °C, inlet air wet bulb temperature: 19.5 °C, inlet water temperature: 7 °C, and outlet water temperature: 12 °C;

※ Heating working condition of standard return air: Inlet air dry bulb temperature: 15 °C, and inlet water temperature: 60 °C. The water flow rate is same with the cooling water flow.

※ The noise value is the standard value of horizontal unit 4. If the external residual pressure of the unit is different, the noise value changes.

Cabinet Type Air-handling Unit (G Series)

(Fresh Air) Performance Parameter Table

Unit model G	Air volume m ³ /h	Cooling capacity (kW)			Heating capacity (kW)			Water flow m ³ /h			Water resistance (kPa)			Noise dB(A)		
		I	II	III	I	II	III	I	II	III	I	II	III	I	II	III
15-G	1500	19.6	24.9	27.5	21.1	28.3	45.2	3.4	4.3	4.8	8.0	21.6	26.0	51	52	56
20-G	2000	27.1	33.2	37.8	28.4	37.8	58.3	4.7	5.8	6.6	10.6	23.5	28.3	56	57	58
25-G	2500	31.7	41.6	45.7	34.9	45.8	70.5	5.5	7.2	7.9	16.1	30.5	36.8	58	58	58
30-G	3000	40.1	50.7	56.6	42.1	55.9	90.5	7.0	8.8	9.8	24.2	31.3	37.9	58	58	58
40-G	4000	53.4	68.5	74.8	58.7	78.7	127.0	9.2	11.8	12.9	30.0	15.4	11.8	58	60	60
50-G	5000	64.8	83.5	93.3	74.1	98.5	158.5	11.2	14.4	16.1	8.0	20.3	17.2	60	62	62
60-G	6000	75.0	101.9	112.2	82.5	112.1	184.6	13.0	17.6	19.4	7.7	25.3	19.3	56	57	58
70-G	7000	88.1	118.9	131.2	96.9	130.8	214.3	15.2	20.5	22.6	7.8	35.1	26.8	59	60	61
80-G	8000	101.3	132.0	150.2	111.4	151.8	248.5	17.5	22.8	25.9	10.3	37.7	28.7	59	59	60
90-G	9000	113.2	152.9	171.5	124.5	168.2	279.5	19.5	26.4	29.6	13.5	11.6	34.6	62	62	62
100-G	10000	134.0	172.2	187.5	139.0	189.4	301.5	23.1	29.7	32.3	17.0	16.9	44.7	63	63	64
120-G	12000	166.2	205.0	224.1	182.8	233.1	372.8	28.7	35.4	38.7	25.7	25.6	49.0	59	61	63
150-G	15000	189.5	258.7	281.4	208.5	284.6	433.3	32.7	44.6	48.5	26.0	29.1	61.2	64	64	65
180-G	18000	238.0	310.5	337.6	250.2	341.6	519.9	41.0	53.5	58.2	25.6	25.5	56.7	65	65	66
200-G	20000	279.0	345.0	374.9	278.0	379.5	577.4	48.1	59.5	64.6	29.4	27.5	61.6	66	67	68
240-G	24000	325.0	414.0	449.9	333.6	455.4	692.9	56.0	71.4	77.5	35.7	39.9	60.8	66	66	67
270-G	27000	368.0	465.7	506.1	375.3	512.3	779.3	63.4	80.3	87.2	36.1	39.4	60.0	69	69	70
300-G	30000	402.0	517.5	565.2	417.0	569.3	870.4	69.3	89.2	97.4	33.3	39.0	59.4	68	69	69
350-G	35000	472.0	603.8	656.0	486.5	664.1	1010.2	81.4	104.1	113.0	37.3	43.5	66.4	68	69	70
400-G	40000	505.4	690.0	749.7	556.0	759.0	1154.5	87.1	118.9	129.2	38.3	43.5	66.4	71	72	72
450-G	45000	568.6	776.3	843.5	625.5	853.9	1299.0	98.0	133.8	145.3	37.0	43.5	66.4	74	74	75

※ Refrigerating working condition of standard fresh air: Inlet air dry bulb temperature: 35 °C, inlet air wet bulb temperature: 28 °C, inlet water temperature: 7 °C, and outlet water temperature: 12 °C;

※ Heating working condition of standard fresh air: Inlet air dry bulb temperature: 7 °C, and inlet water temperature: 60 °C. The water flow rate is same with the cooling water flow.

※ The noise value is the standard value of horizontal unit 4. If the external residual pressure of the unit is different, the noise value changes.

I-excellence Series Modular Air-conditioning Unit



Unit Feature

1. The whole foamed case board adopts an aluminum-plastic composite frame and multiple sealing and splicing. The inner panel is provided with lining steel, high-strength connection cover and L-support for fixing. The buckle sealing and splicing are fixed with bolts. The mechanical strength of cabinet reaches EN1886 Level D1 and the air leakage rate reaches EN1886 Level L1.
2. The profiles adopt aluminum-plastic composite structure. After the panel is formed, the inner and outer plates are completely separated by PVC and EVA materials, and the high-pressure foamed polyurethane thermal insulation material is filled inside, so as to eliminate cold bridge of the cabinet and prevent cold loss.
3. The access door is manufactured by using German technology, and the door leaf is integrally foamed. The combination of seamless dispensing technology with double-edge sealing on the door frame can ensure no deformation and no leakage point under pressure of 3000 Pa.
4. The cabinet enjoys environmentally friendly appearance, sub-series English LOGO, and built-in bolt design. The product has optimized modular design and can be customized for the customer.
5. The stainless steel connecting pipe pressure gauge is neat, beautiful, and anti-corrosion: aluminum alloy flange frame has good flatness, low secondary air leakage, and beautiful appearance; wrap angle support, L-support, flat connection cover and other common parts all adopt toolmaking mode to ensure accurate dimension.
6. The internal splicing of the box is flat and seamless without any accumulation of dust. The water plate adopts a three-dimensional dam structure to ensure that the condensing water is drained during the operation of the unit, so as to prevent the growth of bacteria, and fully meet the requirements of cleanliness and hygiene.
7. In accordance with DIN6701 certification process, each operator is professionally trained by the European bonding technician; the "nuclear grade" insulation cotton splicing and sticking process ensures the insulation and sealing effects, excellent anti-aging and anti-condensation performance of the insulation cotton throughout the unit.
8. The heat exchanger has passed the AHRI certification and is selected by professional software. The software is written in strict accordance with the law of thermal engineering and modified according to the practical usage of coils, so as to make the product more reliable.
9. The stainless steel plate can increase anti-skid treatment according to the user's need: The unit uses natural emptying technology and adopts Z-shaped inclined design for the connection pipes between the inlet pipe and surface air cooler, so as to ensure the water can be drained naturally in the surface air cooler. Such design can eliminate the frost cracking of water pipes in winter caused by incomplete drainage of surface air cooler. The design of the filter strainer retainer allows the customer to conveniently disassemble and maintain the strainer.

I-excellence Series Modular Air-conditioning Unit

Unit Model Denotation Method

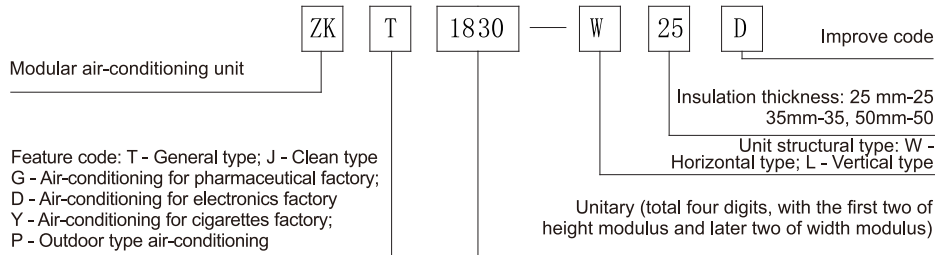

Unit Air Volume Sheet

Unit specification	Unit height mm	Unit width mm	Coil face area m ²	Coil face velocity (m/s)					
				2.25	2.5	3	3.25	3.5	
				Air volume (m ³ /h)					
0606	700	600	0.16	1296	1440	1584	1728	1872	2016
0608	700	800	0.25	2025	2250	2475	2700	2925	3150
0610	700	1000	0.33	2673	2970	3267	3564	3861	4158
0810	900	1000	0.52	4212	4680	5148	5616	6084	6552
0812	900	1200	0.65	5265	5850	6435	7020	7605	8190
0814	900	1400	0.77	6237	6930	7623	8316	9009	9702
1014	1100	1400	0.97	7857	8730	9603	10476	11349	12222
1016	1100	1600	1.14	9234	10260	11286	12312	13338	14364
1018	1100	1800	1.31	10611	11790	12969	14148	15327	16506
1316	1400	1600	1.55	12555	13950	15345	16740	18135	19530
1318	1400	1800	1.78	14418	16020	17622	19224	20826	22428
1418	1500	1800	1.97	15957	17730	19503	21276	23049	24822
1420	1500	2000	2.22	17982	19980	21978	23976	25974	27972
1422	1500	2200	2.47	20007	22230	24453	26676	28899	31122
1622	1700	2200	2.82	22842	25380	27918	30456	32994	35532
1624	1700	2400	3.11	25191	27990	30789	33588	36387	39186
1922	2000	2200	3.29	26649	29610	32571	35532	38493	41454
1924	2000	2400	3.63	29403	32670	35937	39204	42471	45738
1926	2000	2600	3.96	32076	35640	39204	42768	46332	49896
1928	2000	2800	4.30	34830	38700	42570	46440	50310	54180
2226	2300	2600	4.67	37827	42030	46233	50436	54639	58842
2228	2300	2800	5.07	41067	45630	50193	54756	59319	63882
2230	2300	3000	5.46	44226	49140	54054	58968	63882	68796
2430	2500	3000	5.96	48276	53640	59004	64368	69732	75096
2630	2700	3000	6.62	53622	59580	65538	71496	77454	83412
2830	2900	3000	7.12	57672	64080	70488	76896	83304	89712
2832	2900	3200	7.64	61884	68760	75636	82512	89388	96264
2834	2900	3400	8.15	66015	73350	80685	88020	95355	102690
3232	3300	3200	8.88	71928	79920	87912	95904	103896	111888
3234	3300	3400	9.48	76788	85320	93852	102384	110916	119448
3434	3500	3400	10.05	81405	90450	99495	108540	117585	126630
3634	3700	3400	10.62	86022	95580	105138	114696	124254	133812
3834	3900	3400	11.19	90639	100710	110781	120852	130923	140994
4034	4100	3400	11.76	95256	105840	116424	127008	137592	148176
4038	4100	3800	12.35	100035	111150	122265	133380	144495	155610
4040	4100	4000	13.09	106029	117810	129591	141372	153153	164934

Note: 1. Oval tube heat exchanger has over-sized net flow area. It is recommended to select the type according to the face velocity of 3m/s;
2. When the coil face velocity exceeds 3.5m/s, the surface air cooler is not suitable while the heater is applicable.

Purification Modular Air-conditioning Unit



Unit Feature

1. Low air leakage and high strength;
2. Without cold bridge or condensation;
3. High performance and low wind resistance;
4. Anti-freeze surface air cooler design;
5. Professional software design;
6. Prevention of secondary pollution design;
7. Multi-working conditions and standard functional section design;
8. Intelligent control.

Unit Model Denotation Method

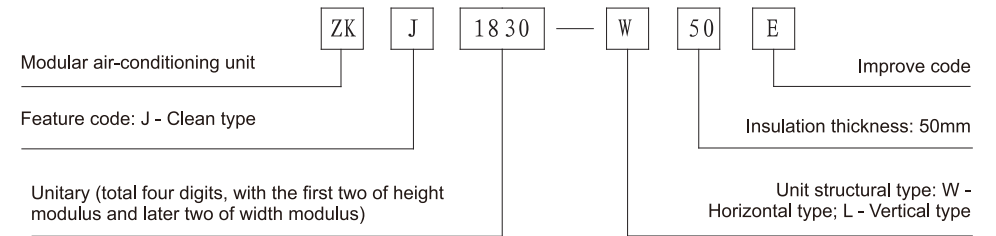

Purification Modular Air-conditioning Unit

Technical Parameters

Unit specification	Unit height mm	Unit width mm	Coil face area m ²	Coil face velocity (m/s)					
				2.00	2.25	2.50	2.75	3.00	3.25
				Air volume (m ³ /h)					
0606	800	700	0.16	1108	1327	1474	1622	1769	1916
0607	800	800	0.21	1482	1667	1852	2037	2223	2408
0608	800	900	0.25	1784	2007	2230	2453	2676	2899
0707	900	800	0.26	1905	2143	2381	2620	2858	3096
0708	900	900	0.32	2294	2581	2867	3154	3441	3728
0709	900	9100	0.37	2683	3018	3353	3689	4024	4359
0710	900	1100	0.43	3072	3455	3839	4223	4607	4991
0711	900	1200	0.48	3460	3893	4325	4758	5190	5623
0712	900	1300	0.53	3849	4330	4811	5293	5774	6255
0713	900	1400	0.57	4121	4636	5152	5667	6182	6697
0811	1000	1200	0.59	4229	4758	5287	5815	6344	6873
0812	1000	1300	0.65	4704	5293	5881	6469	7057	7645
0813	1000	1400	0.70	5037	5667	6296	6926	7556	8185
0814	1000	1500	0.77	5512	6201	6890	7579	8268	8958
0815	1000	1600	0.83	5988	6736	7484	8233	8981	9730
1013	1200	1400	0.89	6411	7212	8014	8815	9616	10418
1014	1200	1500	0.97	7016	7893	8770	9647	10524	11400
1015	1200	1600	1.06	7620	8573	9526	10478	11431	12383
1016	1200	1700	1.14	8225	9253	10282	11310	12338	13366
1115	1300	1600	1.21	8709	9798	10886	11975	13064	14152
1116	1300	1700	1.31	9400	10575	11750	12925	14100	15276
1117	1300	1800	1.40	10092	11353	12614	13876	15137	16399
1118	1300	1900	1.50	10783	12131	13478	14826	16174	17522
1317	1500	1800	1.66	11984	13482	14980	16478	17976	19473
1318	1500	1900	1.78	12804	14405	16006	17606	19207	20807
1319	1500	2000	1.89	13625	15328	17032	18735	20438	22141
1320	1500	2100	2.01	14446	16252	18058	19863	21669	23475
1322	1500	2300	2.23	16088	18099	20110	22121	24132	26142
1422	1600	2300	2.47	17781	20004	22226	24449	26672	28894
1424	1600	2500	2.72	19596	22045	24494	26944	29393	31843
1721	1900	2200	2.90	20892	23503	26114	28726	31337	33949
1722	1900	2300	3.06	22015	24767	27518	30270	33022	35774
1724	1900	2500	3.37	24261	27294	30326	33359	36392	39424
1726	1900	2700	3.68	26508	29821	33134	36448	39761	43075
1926	2100	2700	3.96	28547	32115	35683	39252	42820	46388
1928	2100	2900	4.30	30966	34836	38707	42578	46449	50319
2226	2400	2700	4.67	33644	37850	42055	46261	50466	54672
2228	2400	2900	5.07	36495	41057	45619	50181	54743	59305
2230	2400	3100	5.46	39347	44265	49183	54102	59020	63938
2430	2600	3100	5.96	42924	48289	53654	59020	64385	69751
2432	2699	3300	6.39	46034	51788	57542	63297	69051	74805
2632	2800	3300	7.10	51149	57542	63936	70330	76723	83117
2634	2800	3500	7.58	54605	61430	68256	75082	81907	88733
2834	3000	3500	8.15	58700	66038	73375	80713	88050	95388
2840	3000	4200	9.08	65388	73561	81734	89908	98081	106255
2844	3000	4600	10.11	72818	81920	91022	100125	109227	118329
3046	3200	4800	11.37	81873	92107	102341	112575	122809	133043

Note: When the coil face velocity is less than 3.25m/s, it's not applicable to the surface air cooler, but applicable to heater.

Horizontal Concealed Fan Coil Unit



Unit Feature

1. Low noise: High-quality fan is selected and sound-absorbing material is equipped in the case.
2. Excellent performance: Small-diameter (φ7) high-efficient heat transfer tube covering small-pitch open-window aluminum fin improves the water side and wind wide turbulent flow and disturbance coefficient as well as strengthens the heat exchange.
3. Various matching parts: Stainless steel and extended water plate and return air bellow, etc. are optional.
4. Reliability: Wide once-formed condensate plate, with the thermal insulation thickness of 7 mm, thoroughly preventing condensation; anti-frost and anti-crack type heat exchanger, preventing the coil from frosting and cracking; high-quality oil bearing, without requiring oil supplement.

Unit Model Denotation Method

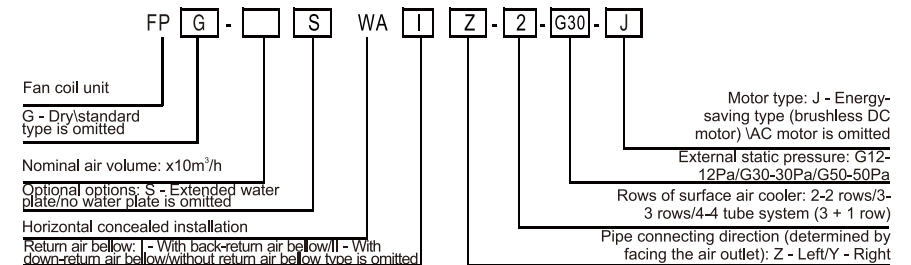

- Note: 1. Judgment criteria for left and right type of unit: Facing the air, if the connecting pipe is on the left, it is left type; otherwise, it is right type;
2. The return air bellow and extended water plate are optional. If required, please specify at the time of ordering;
 3. The speed-adjusting switch and unit power cord shall be prepared by the user;
 4. Example of unit model denotation: FP-68WAIZ.2-G30 represents: unit air volume of 680m³/h, with back return air bellow, left type pipe connecting, external static pressure of 30Pa, AC motor with 2-row coil, and horizontal type fan coil unit.
 5. Standard energy-saving fan coil (brushless DC motor) doesn't have network control. If required, please select the luxury configuration unit of our company.
 6. Dry type fan coil can only select 3-row coil type.

Horizontal Concealed Fan Coil Unit

Performance Parameter Table Under Rated Working Conditions

Unit model	Air volume (m³/h)			Refrigerating capacity (W)			Heating capacity (W)			Water flow (kg/h)		Water resistance (kPa)		Input power (W)		Noise (dB(A))	Unit net weight (kg)	Net weight of return air below	
	High	Med-ium	Low	High	Med-ium	Low	High	Med-ium	Low	Refrig-eration	Heat-ing	Refrig-eration	Heat-ing	AC	DC				
2-row coil	34WA-G12(G30/G50)	340	255	170	1968	1692	1299	3247	2793	2143	338	338	16.9	16.9	36(40/48)	21(28/32)	36.5(38.5/40.5)	11	2.2
	51WA-G12(G30/G50)	510	383	255	2710	2385	1897	4672	4111	3270	466	466	29.2	29.2	49(55/63)	27(35/43)	37.5(40.5/43)	13	2.5
	68WA-G12(G30/G50)	680	510	340	3600	3060	2340	5880	4998	3822	619	619	25.3	25.3	59(69/77)	47(56/62)	40(43/44.5)	14	2.8
	85WA-G12(G30/G50)	850	638	425	4080	3509	2774	7081	6090	4815	701	701	28.9	28.9	76(87/97)	52(65/76)	41(44/46.5)	15	3.0
	102WA-G12(G30/G50)	1020	765	510	4800	4176	3360	8560	7447	5992	825	825	36.2	36.2	94(106/117)	62(84/99)	44(46/48)	16	3.3
136WA-G12(G30/G50)	1360	1020	680	7054	5996	4656	9782	8315	6456	1212	1212	38.6	38.6	132(150/172)	101(118/138)	44.5(46.5/48.5)	24	4.4	
3-row coil	34WA-G12(G30/G50)	340	255	170	2350	2021	1551	3647	3137	2407	404	404	26.9	26.9	36(40/45)	20(27/31)	35.5(38/41.5)	12	2.2
	51WA-G12(G30/G50)	510	383	255	3200	2816	2240	5222	4595	3655	550	550	26.8	26.8	47(55/60)	26(34/42)	37.5(40/42.5)	14	2.5
	68WA-G12(G30/G50)	680	510	340	4200	3570	2730	6728	5719	4373	722	722	21.8	21.8	55(65/78)	45(55/61)	39(42.5/44.5)	15	2.8
	85WA-G12(G30/G50)	850	638	425	5030	4326	3420	7903	6797	5374	864	864	29.9	29.9	75(82/95)	51(63/75)	41(43.5/46)	16	3.0
	102WA-G12(G30/G50)	1020	765	510	6020	5237	4214	9425	8200	6598	1034	1034	36.4	36.4	94(107/116)	61(83/97)	44(45.5/48)	17	3.3
	136WA-G12(G30/G50)	1360	1020	680	8120	6902	5359	12328	10479	8137	1395	1395	29.9	29.9	128(148/165)	99(116/136)	44.5(45.5/49)	25	4.4
	170WA-G12(G30/G50)	1700	1275	850	9400	8272	6392	15963	14047	10855	1615	1615	39.4	39.4	150(170/200)	115(145/175)	46.5(48/50.5)	28	4.5
	204WA-G12(G30/G50)	2040	1530	1020	11800	10148	7788	18463	15878	12185	2028	2028	40	40	188(211/245)	155(180/221)	48(50/52)	31	5.3
238WA-G12(G30/G50)	2380	1785	1190	13200	11484	8920	20766	18066	14536	2268	2268	42	42	225(236/280)	182(193/255)	50.5(51.5/53)	34	6.0	
4-tube system (3+1 row coil)	34WA-G12(G30/G50)	340	255	170	2250	1935	1485	3650	3191	2421	387	387	20	15	36(40/45)	20(27/31)	35.5(38/41.5)	12.5	2.2
	51WA-G12(G30/G50)	510	383	255	3100	2728	2170	5270	4591	3533	533	533	20	30	47(55/60)	26(34/42)	37.5(40/42.5)	14.5	2.5
	68WA-G12(G30/G50)	670	503	335	4000	3400	2600	6720	5720	4330	687	687	30	30	55(65/78)	45(55/61)	39(42.5/44.5)	15.5	2.8
	85WA-G12(G30/G50)	820	615	410	4850	4171	3298	8350	7111	5411	833	833	28	15	75(82/95)	51(63/75)	41(43.5/46)	16.5	3.0
	102WA-G12(G30/G50)	1010	758	505	5750	5002.5	4025	9700	8390	6390	988	988	35	20	94(107/116)	61(83/97)	44(45.5/48)	17.5	3.3
	136WA-G12(G30/G50)	1300	975	650	7300	6205	4818	11500	9925	7525	1254	1254	28	15	128(148/165)	99(116/136)	44.5(45.5/49)	26	4.4
	170WA-G12(G30/G50)	1680	1260	840	8700	7656	5916	12150	10492	7992	1495	1495	35	20	150(170/200)	115(145/175)	46.5(48/50.5)	29	4.5
	204WA-G12(G30/G50)	2000	1500	1000	10500	9030	6930	13500	11610	8810	1804	1804	38	30	188(211/245)	155(180/221)	48(50/52)	32	5.3
	238WA-G12(G30/G50)	2330	1748	1165	12100	10527	8470	13030	11161	8611	2079	2079	41	40	225(236/280)	182(193/255)	50.5(51.5/53)	35	6.0
	Fan	Metal forward curved multi-blades centrifugal fan																	
Power supply	1/N/PE AC 220V 50Hz																		
Heat exchanger	Copper tube cover louver aluminum fin, with working pressure of 1.6MPa																		
Piping	Cold water coil connecting to pipe Rc3/4 (DN20), hot water coil connecting to pipe Rc1/2 (DN15), and condensate water connecting to pipe R3/4 (DN20)																		

- Note: 1. The unit noise value is measured in the anechoic room and 1m away from the air outlet of unit. (see page 14 for details);
 2. Test conditions under refrigerating working condition: Air inlet dry bulb temperature: 27 °C, wet bulb temperature: 19.5 °C, water inlet temperature: 7 °C, and water outlet temperature: 12 °C;
 3. Test conditions under heating working condition: Air inlet dry bulb temperature: 21 °C, and water inlet temperature: 60 °C;
 4. The air volume, refrigerating capacity, heating capacity and other parameters in the table are all based on the unit without return air below; if with return air below, the relevant parameters shall multiply with the correction coefficient (0.95 for air volume, and 0.97 for refrigerating capacity and heating capacity);
 5. The left and right type of unit can be changed on site; however, after changing, the refrigerating and heating capacity shall multiply with the correction coefficient of 0.9-0.95.

Surface Mounted Fan Coil Unit

Horizontal/vertical Surface Mounted Type

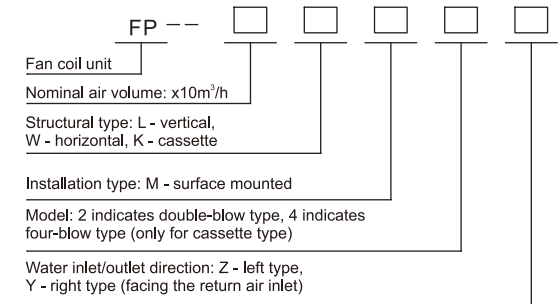

- Note:
 Elegant appearance: Beautiful view
 Saving space: Maximum thickness of 250mm
 The standard control mode is three-speed switch control, with remote control and wire control optional
 The vertical surface mounted type has up-air outlet type only
 The horizontal surface mounted type has down-return air and front air outlet type only
 Judgment criteria for left and right type of unit: Facing the return air inlet, if the connecting pipe is on the left, it is left type; otherwise, it is right type;

Performance	Type	FP-51	FP-68	FP-85	FP-102	FP-136	FP-170	FP-204
	Rated air volume (m³/h)	H	510	680	850	1020	1360	1700
M		384	510	638	765	1020	1275	1530
L		258	340	425	510	680	850	1020
Refrigerating capacity (W)	H	2680	3640	4480	5350	7180	8950	10600
	M	2270	3020	3770	4530	6040	7515	8350
	L	1650	2170	2710	3250	4340	5420	6050
Heating capacity (W)	H	4050	5400	6750	8100	10800	13500	16200
	M	3240	4290	5370	6430	8580	10720	13380
	L	2260	3000	3710	4450	5950	7450	9580
Power (W)	H	51	62	71	94	124	152	188
Noise (dB(A))	H	39	41	43	45	46	48	50
Power supply	220~240V/1P/50Hz							
Coil working pressure	1.6MPa							
Inlet/outlet water pipe joint	Rc3/4 (internal thread)							
Condensate water joint	φ20mm							
Water flow (Kg/h)	H	520	700	876	1050	1400	1750	1990
Water resistance (kPa)	H	5.9	11.9	19.7	31.9	37.8	24.2	29.4
Weight (Kg)		19	21	22	27	39	47	49

- Specification:
 1. Measurement condition of refrigerating capacity: Air inlet dry bulb temperature of 27 °C, wet bulb temperature of 19.5 °C, water inlet temperature of 7 °C, and water outlet temperature of 12 °C.
 2. Measurement condition of heating capacity: Air inlet dry bulb temperature of 21 °C, and water inlet temperature of 60 °C. The water supply working condition is same with the refrigeration condition.
 3. The sound pressure level value is measured in the anechoic room or semi-anechoic room, 1m below and before the unit under high-grade operation.
 4. H, M and L refer to high, medium and low grade respectively.

Surface Mounted Fan Coil Unit

Cassette Double-blow Type



Note:
 Km2 indicates cassette double-blow type unit;
 Suitable for long and narrow space, such as corridor or long and narrow living room or dining room;
 Two-way air outlet design, guaranteeing uniform air flow;
 No left/right type division of unit;
 The unit is equipped with condensate water lift pump (with lift of 700 mm) and remote control.

Performance		Type	FP-51KM2	FP-68KM2	FP-85KM2	FP-102KM2	FP-136KM2	FP-170KM2	FP-204KM2
		Rated air flow (m³/h)	High-grade	510	680	850	1020	1360	1700
Refrigerating capacity (W)	High-grade	2700	3600	4500	5400	7200	9000	10800	
Heating capacity (W)	High-grade	4050	5400	6750	8100	10800	13500	16200	
Power (W)	High-grade	52	62	76	96	134	152	189	
Noise (dB(A))	High-grade	39	41	43	45	46	48	50	
Coil	Type	High-quality copper tube mechanic expansion-join corrugated fin							
	Working pressure	1.6MPa							
Inlet/outlet water pipe joint		Rc3/4 (internal thread)							
Condensate water joint		φ 20mm							
Overall dimension	Lifting hole: B	892	892	1012	1252	1252	1732	1732	
	Panel: L	1083	1083	1203	1443	1443	1924	1924	
Water flow (Kg/h)	High-grade	520	700	876	1050	1400	1750	1990	
Water resistance (Kpa)	High-grade	5.9	11.9	19.7	31.9	37.8	24.2	29.4	
Weight (Kg)		36	36	42	46	46	57	60	

Note:
 1. Air volume refers to that with the outlet static pressure of 0Pa.
 2. Measurement condition of refrigerating capacity: Air inlet dry bulb temperature of 27 °C, wet bulb temperature of 19.5 °C, water inlet temperature of 7 °C, and water outlet temperature of 12 °C.
 3. Measurement condition of heating capacity: Air inlet dry bulb temperature of 21 °C, and water inlet temperature of 60 °C.

Surface Mounted Fan Coil Unit

Cassette Double-blow Type



Note:
 Type 390 adopt natural drainage, the standard type doesn't equipped with lift pump or remote control, while the luxury type is equipped with remote control but no lift pump;
 Type 290 is extra-thin type, equipped with lift pump (with lift of 700 mm) and remote control.
 No left/right type division of unit;

Performance		Type	FP-34KM4	FP-51KM4	FP-68KM4	FP-85KM4	FP-102KM4	FP-136KM4	FP-170KM4	FP-204KM4	FP-238KM4
		Rated air flow (m³/h)		340	510	680	850	1020	1360	1700	2040
Refrigerating capacity (W)		1800	2700	3600	4500	5400	7200	9000	10800	12150	
Heating capacity (W)		2700	4050	5400	6750	8100	10800	13500	16200	17500	
Piping size	Inlet/outlet water pipe	Rc3/4(DN20)									
	Condensate pipe	φ20									
Water flow Kg/h		350	520	700	860	1050	1400	1750	1990	2320	
Water resistance kpa		30	30	30	30	40	40	40	40	50	
Input power W		37	52	62	76	96	134	152	189	228	
Noise dB(A)		≤37	≤39	≤41	≤43	≤45	≤46	≤48	≤50	≤52	
Connection type		Internal thread connection									
Power supply		1/N/PE/AC 220V 50HZ									
Unit net weight (kg)	Type 290	23	23	23	34	34	34	48	48	48	
	Type 390	23	23	23	34	34	34	48	48	48	
Working pressure (Mpa)		1.6									
Overall dimension	A*B	650*650	650*650	650*650	850*850	850*850	850*850	1050*1050	1050*1050	1050*1050	
	L*S	570*570	570*570	570*570	730*730	730*730	730*730	930*930	930*930	930*930	
	K*H	280*616	280*616	280*616	440*776	440*776	440*776	640*976	640*976	640*976	

Nominal working condition of unit:
 Working condition of refrigeration: Air inlet dry bulb temperature of 27 °C, wet bulb temperature of 19.5 °C, water inlet temperature of 7 °C, and water outlet temperature of 12 °C;
 Working condition of heating: Air inlet dry bulb temperature of 21 °C, and water inlet temperature of 60 °C;
 (Input power of type 290 unit increases 20W)